



Heat Pump for Heating & Cooling & DHW
Service Manual

Model:

BLN-006TC1

BLN-012TC1、BLN-012TC3

BLN-018TC1、BLN-018TC3

ARDEN Heat Pumps Pty Ltd

Service Manual

contents

1. Product introduction	4
1.1. Product model pictures	4
1.2. Parameter Table	5
1.3. Dimension.....	6
1.3.1. BLN-006TC1	6
1.3.2. BLN-012TC1、BLN-012TC3.....	6
1.3.3. BLN-018TC1、BLN-018TC3.....	7
1.4. Exploded view.....	8
1.4.1. BLN-006TC1、BLN-012TC1、BLN-012TC3.....	8
1.4.2. BLN-018TC1、BLN-018TC3.....	9
1.5. System diagrams and performance curves	10
1.5.1. Schematic diagram of the cooling system	10
1.5.2. How heat pumps work.....	10
1.5.3. Introduction to Heat Pump System Components	11
1.5.4. Heating Performance Curve.....	13
2. Product selection and installation	18
2.1. Product installation instructions and special precautions	18
2.1.1. Disclaimer	18
2.1.2. warning.....	18
2.1.3. Precautions.....	19
2.2. Installation.....	19
2.2.1. Heat pump installation	19
2.2.2. Auxiliary pump installation	20
2.3. Pipeline installation; water pressure commissioning; pipeline insulation requirements	21
2.3.1. Water distribution installation system diagram	21
2.4. Precautions for electrical wiring	23
2.5. Room heat load calculation	24
2.5.1. basic requirements	24
2.5.2. water system design	26
2.5.3. Distributor and water collector configuration principal.....	27
2.5.4. Selection of floor heating heat pump unit.....	27
2.6. *Waterway antifreeze protection	37
3. Electrical operation.....	39
3.1. Control.....	39
3.1.1. out of service	39
3.1.2. DC water pump control (PWM)	39
3.1.3. Start control.....	39
3.1.4. High temperature sterilization.....	42
3.1.5. Silent mode.....	42
3.1.6. Waterway emptying mode/forced open water pump	42
3.1.7. Forced defrost	42

ARDEN Heat Pumps Pty

3.1.8. Linkage control	42
3.1.9. Refrigerant recovery function	43
3.1.10. Expiry date password setting	43
3.1.11. Electric heating control EH1/gas control signal output	43
3.1.12. Heating auxiliary electric heater EH2	44
3.1.13. Unit auxiliary pump P_c	45
3.1.14. Hot water three-way valve SV1	45
3.1.15. Air conditioning three-way valve SV2	45
3.1.16. Air conditioner secondary water pump P_b (secondary system)	46
3.1.17. Heat source hot water pump P_e	46
3.1.18. Heat source heating water pump P_f	47
3.1.19. winter frost protection	47
3.1.20. Host water flow switch protection	48
3.1.21. Protection against excessive temperature difference between inlet and outlet pipes	49
3.1.22. High voltage protection	50
3.1.23. Low voltage protection	50
3.1.24. Exhaust temperature too high protection	50
3.2. Display and operation of the wire controller	51
3.2.1. Wire controller interface display and operation	51
3.2.2. Setting and operation of climate temperature curve	55
3.2.3. Setting and operation of unit tooling number	57
3.2.4. Network connection method and display of multiple units	58
3.2.5. Operation method of unit status parameter query	59
3.2.6. Factory parameter setting method	61
3.2.7. Reset	63
3.2.8. *Touch screen controller operation	64
L parameter setting table	80
P parameter setting table	81
3.3. Setting method of pump flow range setting value	85
3.4. Outdoor unit electric control box layout	85
3.4.1. BLN-006TC1	85
3.4.2 BLN-012TC1	86
3.4.3. BLN-006TC1/ BLN-012TC1/ BLN-018TC1	86
3.4.4. BLN-012TC3	87
3.4.5. BLN-018TC3	87
3.1.6. BLN-012TC3/BLN-018TC3	88
3.5. Host unit port definition diagram	88
3.5.1. Main control board port definition diagram (AP1)	88
3.5.2. Port Definition Diagram of Water Pump Expansion Board (AP3)	89
3.5.3. Port definition diagram of switching power supply (AP4)	91
3.5.4. DC fan board port definition diagram (AP5)	92
3.5.5. Compressor driver board port definition diagram (AP4)	92
3.6. Fault code and fault reason	94

ARDEN Heat Pumps Pty

3.7. Waterway installation and wiring	99
3.7.1. Comparison of system legends	99
3.7.2. Single floor heating mode water system installation diagram	101
3.7.3. Heating or cooling mode water system installation diagram.....	101
3.7.4. Schematic diagram of wiring in floor heating, heating, and cooling modes	102
3.7.5. Hot water + cooling or hot water + heating mode water system installation diagram.....	103
3.7.6. Hot water + floor heating mode water system installation diagram.....	103
3.7.7. Water wiring diagram for hot water + cooling, hot water + heating, hot water + floor heating modes	104
3.7.8. Mixed mode waterway system installation diagram.....	105
3.7.9. Wiring diagram in hybrid mode	106
3.7.10. Cascade mode waterway installation schematic	107
3.7.11. Cascading mode water circuit wiring diagram.....	108
3.7.12. Floor heating + refrigeration + hot water + gas waterway installation schematic	109
3.7.13. Floor heating + refrigeration + hot water + gas water circuit wiring diagram.....	110
3.7.14. Three-way valve wiring method	111
3.8. Wiring diagram of each model	112
3.8.1. BLN-006TC1/ BLN-012TC1/ BLN-018TC1	112
3.8.2. BLN-012TC3/ BLN-018TC3	113
3.9. NCT Sensor Resistance Table	114
4. Error Diagnosis and Treatment.....	116
4.1. maintenance tools	116
4.2. Model disassembly and parts	118
4.3. Troubleshooting and maintenance of common fault codes	141
Schedule	153
Schedule A: Unit Ground Heat Dissipation and Ground-to-Soil Heat Loss.....	153
(1) Heat dissipation per unit ground area of PE-X pipe and heat loss when turning downwards.....	153
(2) Heat dissipation per unit ground area of PB pipe and heat loss when turning downwards.....	156
Schedule B: Coefficient of Expansion of Water.....	159

1. Product introduction

1.1. Product model pictures



<p>Model</p>	<p>BLN-006TC1 BLN-012TC1、BLN-012TC3</p>	<p>BLN-006TC1 BLN-012TC1、BLN-012TC3</p>
<p>Picture</p>		
<p>Model</p>	<p>BLN-018TC1、BLN-018TC3</p>	
<p>Picture</p>		

Table 1-1

1.2. Parameter Table

DC Inverter heat pump (R290)							
Model:		BLN-006TC1	BLN-012TC1	BLN-012TC3	BLN-018TC1	BLN-018TC3	
Heating Capacity Range		kW	3.00~9.05	4.30-15.20	4.30-15.20	7.24-21.9	7.24-21.9
Heating 1	Heating Capacity	kW	6.18	12.05	12.05	18	18
	Power Input	kW	1.30	2.61	2.61	3.94	3.94
	COP	W/W	4.75	4.61	4.61	4.57	4.57
Heating 2	Heating Capacity	kW	6.16	12.18	12.18	18	18
	Power Input	kW	2.03	4.05	4.05	5.90	5.90
	COP	W/W	3.03	3.01	3.01	3.05	3.05
Cooling 1	Cooling Capacity	kW	5	10	10	15	15
	Power Input	kW	1.91	3.51	3.51	5.77	5.77
	EER	W/W	2.62	2.85	2.85	2.60	2.60
Cooling 2	Cooling Capacity	kW	6.05	12.11	12.11	17.95	19.95
	Power Input	kW	1.57	3.01	3.01	4.66	4.66
	EER	W/W	3.85	4.02	4.02	3.85	3.85
ERP Level (35℃)		/	A+++	A+++	A+++	A+++	A+++
ERP Level (55℃)		/	A+++	A+++	A+++	A+++	A+++
SCOP (35℃)		/	4.83	4.85	4.85	4.90	4.90
SCOP (55℃)		/	3.86	3.84	3.84	3.85	3.85
Rated water flow		m3/h	1.03	1.90	1.90	3.1	3.1
Rated voltage		V	230V	230V	400V/3N~	230V	400V/3N~
Frequency		Hz	50	50Hz	50Hz	50Hz	50Hz
Maximum input power		kW	3.5	5.4	5.4	7.5	10.5
Maximum input current		A	15	25	10	35	17
Fuse protector	rated current	/	15	25	10	35	18
	fusing current	/	23	34	15	53	26
Air switch		A	16	32	16	50	25
Sectional area of conductor		mm ²	2.5	4	2.5	6	4
Water Piping Connections		inch	G1"	G1"	G1"	G1 1/4"	G1 1/4"
High pressure valve cut-off pressure		MPa	3.2	3.2	3.2	3.2	3.2
Low pressure valve cut-off pressure		MPa	0.8	0.8	0.8	0.8	0.8

Table 1-2

Rated Test Conditions:

Heating¹: Ambient Temp 7℃/6℃(DB/WB),Water-In/Out Temp 30℃/35℃; Heating²: Ambient Temp 7℃/6℃(DB/WB),Water-In/Out Temp 47℃/55℃

Cooling¹: Ambient Temp 35℃/24℃(DB/WB),Water-In/Out Temp 12℃/7℃; Cooling²: Ambient Temp 35℃/24℃(DB/WB),Water-In/Out Temp 23℃/18℃

Note: Parameters are subject to change without prior notice. Please refer to the unit nameplate.

1.3. Dimension

1.3.1. BLN-006TC1

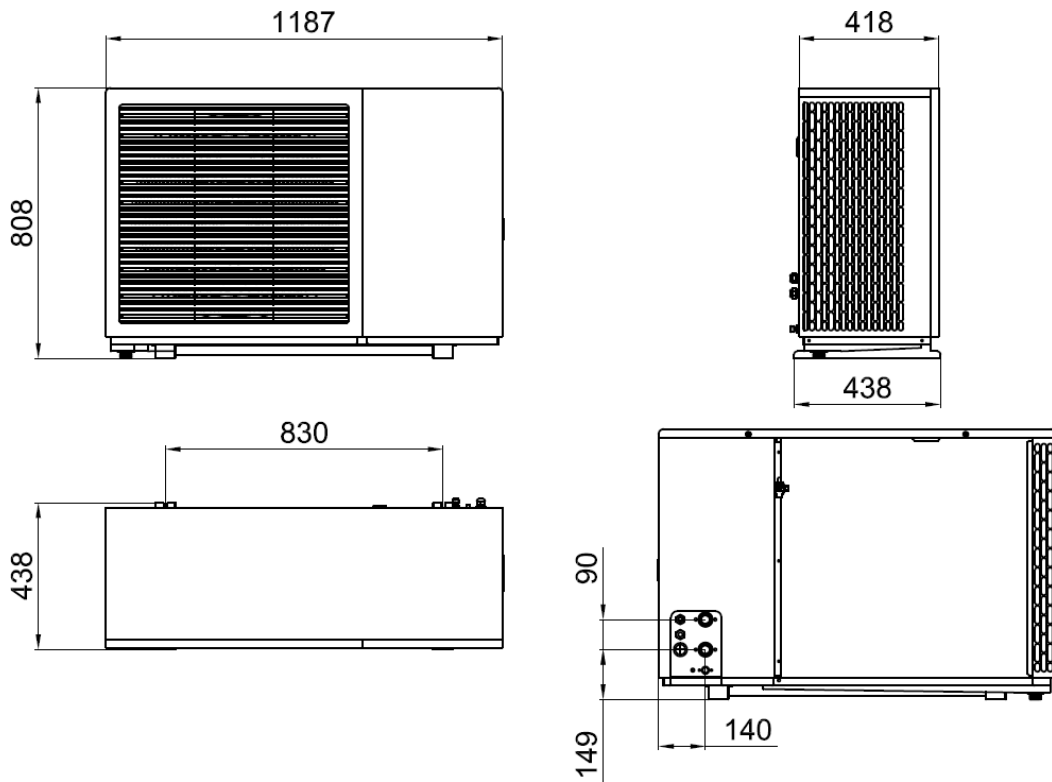

Figure 1-1

1.3.2. BLN-012TC1 \ BLN-012TC3

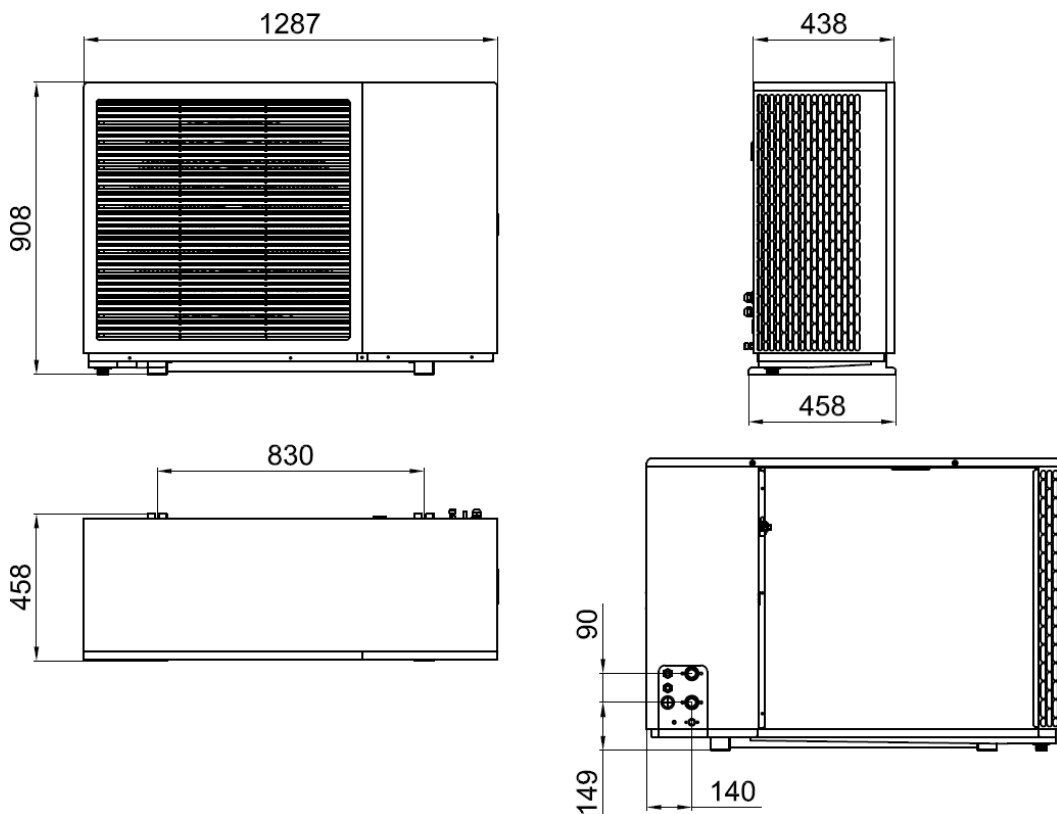

Figure 1-2

1.3.3. BLN-018TC1 \ BLN-018TC3

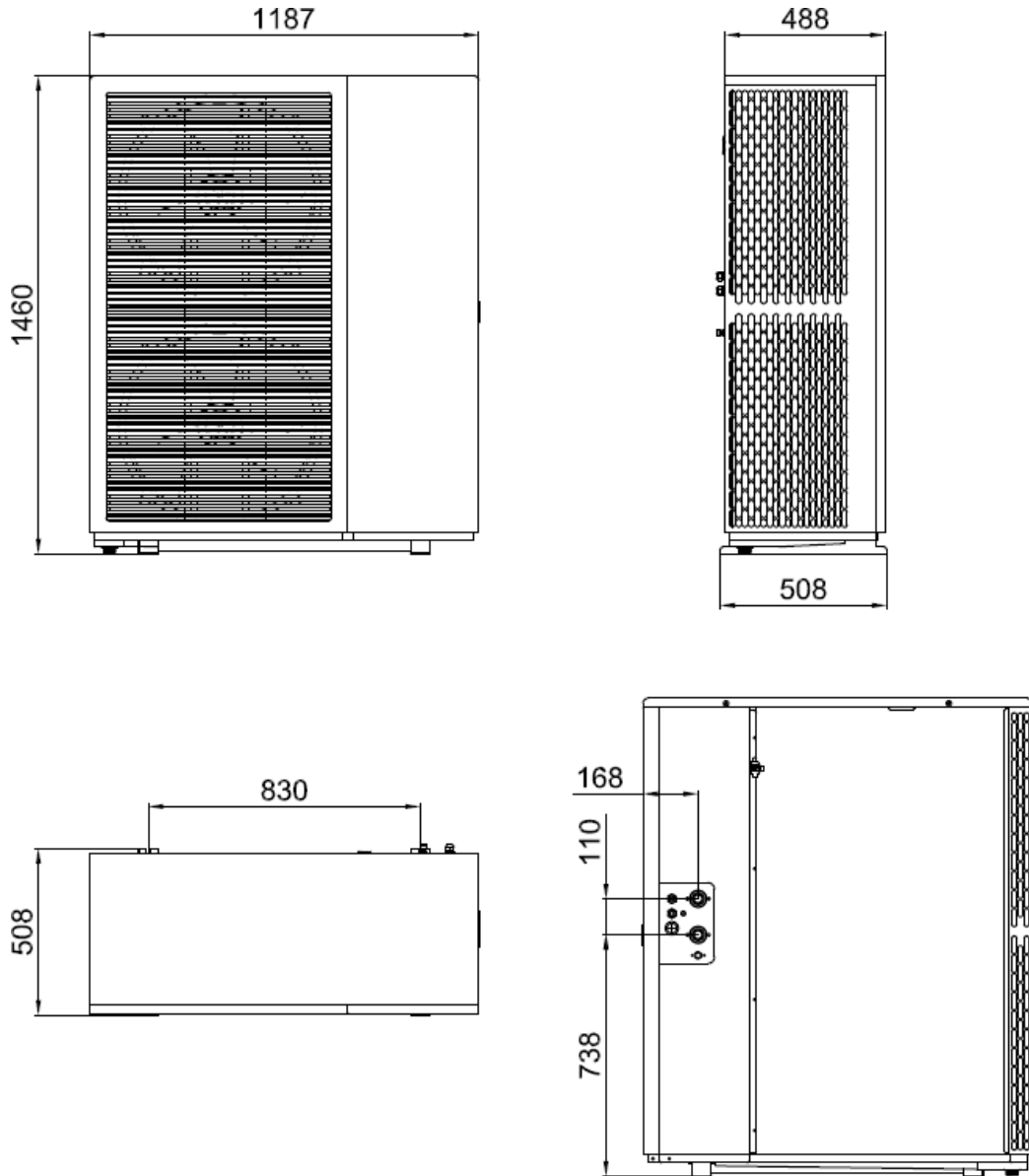

Figure 1-3

1.4. Exploded view

1.4.1. BLN-006TC1 、 BLN-012TC1 、 BLN-012TC3

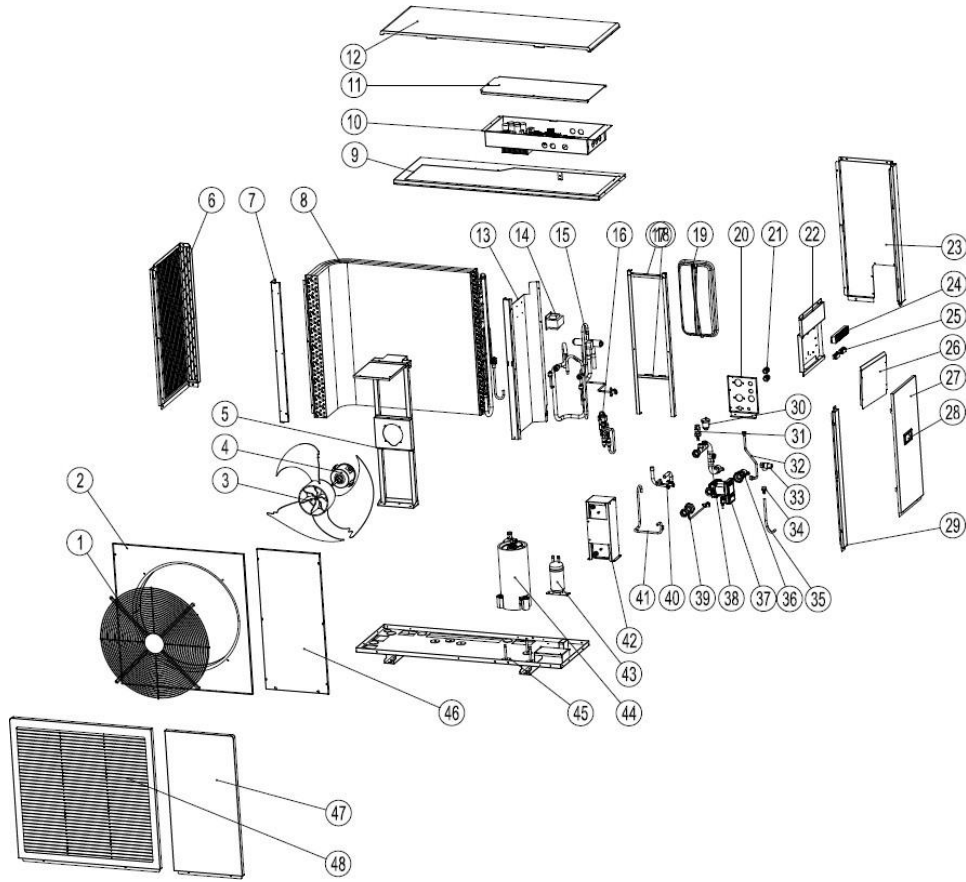

Figure 1-4

No.	Component	No.	Component	No.	Component
1	Outlet	17	Expansion valve bracket	33	safety valve
2	Baffle	18	Expansion tank fixing plate	34	Safety valve drain connector
3	Wind leaf	19	Expansion tank	35	drain hose
4	Motor	20	seat plate	36	Water pump inlet pipe
5	Motor bracket	21	waterproof connector	37	Frequency conversion water pump
6	Left side plate	22	Terminal block mounting plate	38	plate swap out water pipe
7	left column	23	rear right panel	39	Plate replacement water inlet pipe
8	Evaporator	24	terminal block	40	Replace the plate into the fluorine tube
9	Top frame	25	Crimping buckle	41	Replace the fluorine tube with the plate
10	Electrical control part	26	junction box cover	42	Plate heat exchanger
11	Electrical box cover	27	right side panel	43	Liquid reservoir (non-standard configuration)
12	Top cover	28	draw hands	44	compressor
13	Section	29	right front pillar	45	chassis components
14	Electrical antibody	30	Flow switch	46	right panel
15	Four -pass valve components	31	Auto exhaust valve	47	front right panel
16	Electronic expansion valve component	32	Expansion tank connection	48	front left panel

1.4.2. BLN-018TC1 \ BLN-018TC3

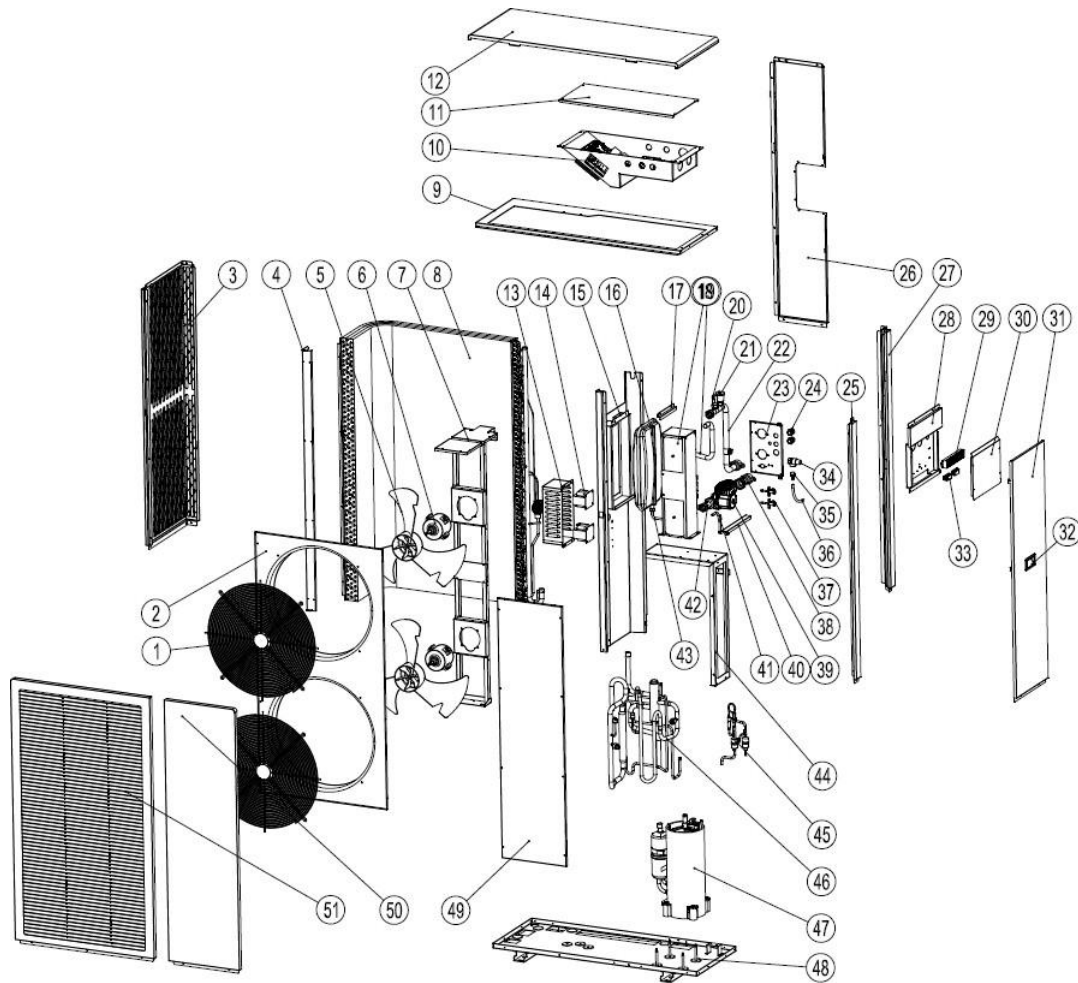

Figure 1-5

No.	Component	No.	Component	No.	Component
1	Air outlet grille	18	Plate heat exchanger	35	Safety valve drain connector
2	Baffle	19	Replace the plate into the fluorine tube	36	drain hose
3	left side panel	20	Flow switch	37	Repair shut-off valve
4	left column	21	Auto exhaust valve	38	Water pump inlet pipe
5	wind blade	22	plate swap out water pipe	39	Frequency conversion water pump
6	motor	23	seat plate	40	water pump bracket
7	motor bracket	24	waterproof connector	41	Replace the fluorine tube with the plate
8	Evaporator	25	front right pillar	42	Plate replacement water inlet pipe
9	top frame	26	rear right panel	43	Expansion tank connection
10	Electronic control components	27	rear right column	44	Board replacement bracket
11	Electrical box cover	28	Terminal block mounting plate	45	Electronic Expansion Valve Assembly
12	top cover	29	terminal block	46	Four-way valve assembly
13	Reactor protection cover	30	junction box cover	47	compressor
14	Reactor	31	right side panel	48	chassis components
15	Partition	32	draw hands	49	right panel
16	Expansion tank	33	Crimping buckle	50	front right panel
17	Expansion tank fixing plate	34	safety valve	51	front left panel

1.5. System diagrams and performance curves

1.5.1. Schematic diagram of the cooling system

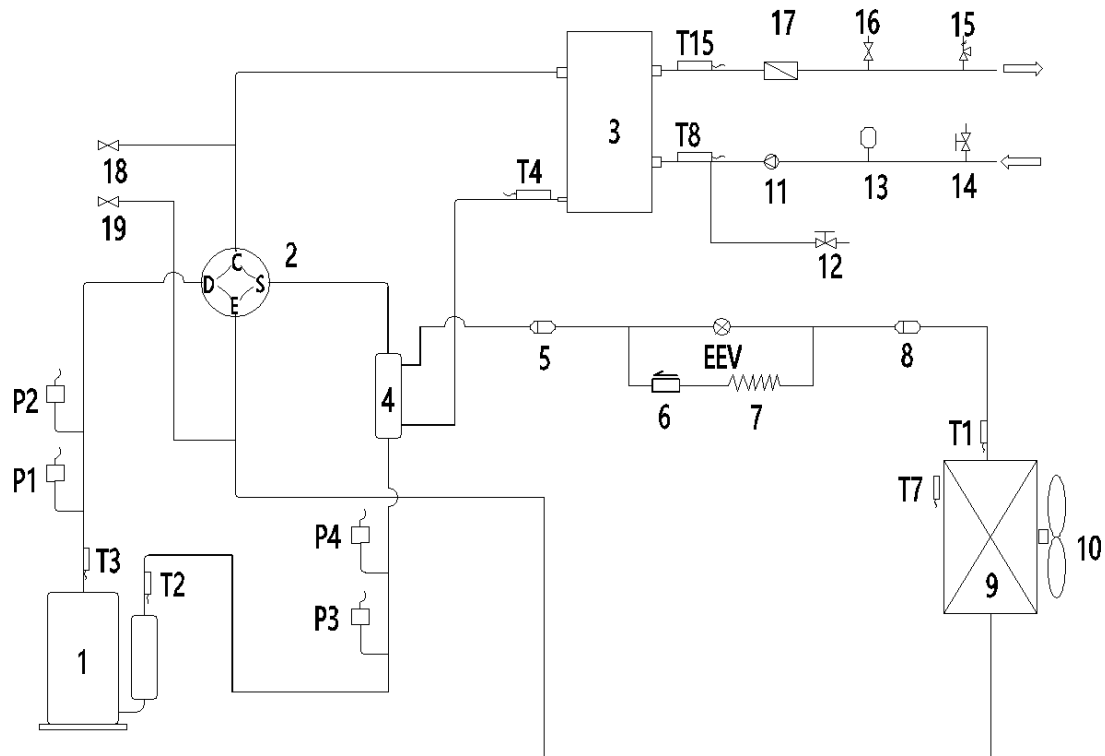

Figure 1-6

Code	Component	Code	Component	Code	Component
1	compressor	12	manual drain valve	T4	Inner coil temperature sensor
2	Four-way reversing valve	13	Expansion tank	T7	ambient temperature sensor
3	plate heat exchanger	14	Manual exhaust valve (non-standard configuration)	T8	Inlet water temperature sensor
4	heat recovery	15	safety valve	T15	Outlet water temperature T15 sensor
5	filter 1	16	Auto exhaust valve	P1	High pressure pressure sensor
6	check valve	17	Flow switch	P2	High voltage switch
7	Auxiliary throttle capillary	18	High Pressure Service Valve	P3	Low Pressure Sensor
8	filter 2	19	Low Pressure Service Valve	P4	low voltage switch
9	Finned Exchanger	T1	coil temperature sensor	EEV	main electronic expansion valve
10	outdoor fan	T2	Suction temperature sensor		
11	Circulating pump	T3	exhaust temperature sensor		

1.5.2. How heat pumps work

The heat pump system is mainly composed of four major components: compressor, condenser, throttling device and evaporator. Its working principle is to use electric energy to drive the compressor to compress the low-temperature and low-pressure gaseous refrigerant into high-temperature and high-pressure steam, then condense and dissipate heat in the condenser (plate heat exchanger), and release the heat to the heat transfer medium (water), the heat source is provided to the user through the heat transfer medium (water) for heating or domestic hot water; the condensed medium-temperature and high-pressure refrigerant

becomes a low-temperature and low-pressure liquid after being throttled by the throttling device, and then passes through the evaporator (fin Plate heat exchanger) absorbs heat into the air environment and vaporizes to form a low-temperature and low-pressure gas, which enters the compressor again to be compressed, thus forming a repeated cycle.

Working principal diagram:

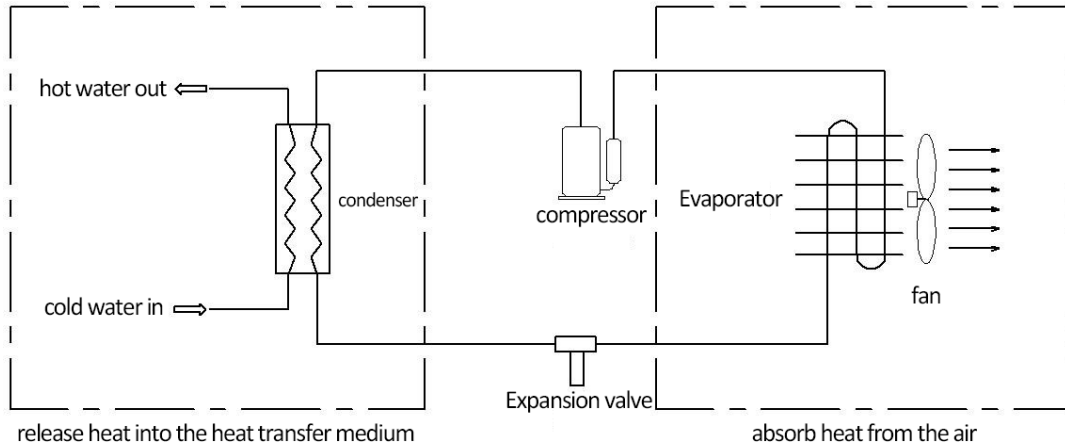















Figure 1-7

1.5.3. Introduction to Heat Pump System Components

No.	Picture	Name	Function Description
1		DC inverter compressor	The compressor is the heart of the heat pump system. It is a "steam pump" that compresses low-temperature and low-pressure vapor into high-temperature and high-pressure vapor, and provides power for the refrigerant to circulate in the heat pump system.
2		plate heat exchanger	Plate heat exchanger is a kind of water side heat exchanger. It is used as a condenser and an evaporator. When heating, it is a condenser, which condenses the high-temperature and high-pressure gaseous refrigerant into a medium-temperature and high-pressure liquid state, and transfers the condensation heat to the heat exchange medium (water); when cooling, it is an evaporator, which converts the low-temperature and low-pressure liquid state The refrigerant evaporates into a gaseous refrigerant, absorbing heat from the heat transfer medium (water) during evaporation.
3		Finned heat exchanger	Finned heat exchangers can be used as condensers and evaporators. When heating, it is an evaporator, which evaporates the low-temperature and low-pressure liquid refrigerant into a gaseous state and absorbs the heat in the air. When cooling, it is a condenser, which condenses the high-temperature and high-pressure gaseous refrigerant into a medium-temperature and high-pressure liquid, and dissipates heat into the air.

ARDEN Heat Pumps Pty

4		reservoir	When the heat pump unit is running, due to changes in working conditions or adjustments to the cooling capacity, the refrigerant circulation in the system will change. After the liquid receiver is installed, the liquid storage capacity of the liquid receiver can be used to balance and stabilize the refrigerant circulation in the system, so that the heat pump unit can always run efficiently and reliably.
5		Gas-liquid separator	The refrigerant returned from the evaporator to the compressor is separated into gas and liquid, preventing liquid refrigerant from entering the compressor, damaging the lubrication or damaging the pump body.
6		heat recovery	Increase the subcooling degree of the heat pump system, increase the suction temperature, and improve the capacity and energy efficiency of the heat pump unit
7		Electronic expansion valve	Throttling and pressure-reducing device, throttling medium-temperature and high-pressure liquid refrigerant into low-temperature and low-pressure liquid refrigerant
8		Four-way reversing valve	Change the refrigerant flow direction to realize the switching function of cooling, heating and defrosting
9		Solenoid valve (spray solenoid valve, throttle solenoid valve)	Control the circulation and disconnection of refrigerant in the pipeline by opening and closing the solenoid valve
10		Pressure Sensor	The role of the high-pressure pressure sensor: unit high-pressure protection, compressor/fan frequency limiting function control. The role of the low-pressure pressure sensor: unit low-pressure protection, compressor/fan frequency limiting function control, suction superheat control.
11		Pressure Switch	High-pressure switch: When the exhaust pressure of the heat pump system is higher than the protection value of the high-voltage switch, the high-pressure switch is disconnected, forcing the unit to stop working to avoid damage to the unit. Low-pressure switch: When the suction pressure of the heat pump system is lower than the protection value of the low-pressure switch, the low-pressure switch is disconnected, forcing the unit to stop working, and preventing the unit from being damaged.
12		Flow switch	When the water flow of the heat pump system is cut off or the flow rate is low, the water flow switch is disconnected and the heat pump unit stops working.
13		Auto exhaust valve	Automatically removes air from the water system

ARDEN Heat Pumps Pty





14		safety valve	When the pressure of the water system exceeds the design value of the safety valve, the safety valve will automatically open to release the pressure, and control the pressure of the water system not to exceed the specified design value, which plays an important role in protecting personal safety and equipment operation.
15		Expansion tank	The expansion tank plays the role of buffering pressure fluctuations and part of the water supply in the water system.
16		DC circulating water pump	The circulating water pump provides power for transporting the heat transfer medium (water) in the heat pump water system, and then takes away the heat in the water side heat exchanger through the heat transfer medium (water) to increase or decrease the temperature of the heat transfer medium (water).
17		Outdoor fan (DC motor + blades)	The outdoor fan provides strong air convection during the heat exchange of the fin heat exchanger to enhance the heat exchange effect.
18		Service valves (high pressure service valves, low pressure service valves)	When the heat pump system is in maintenance, discharge and charge refrigerant and vacuumize through this valve.

Table 1-3

1.5.4. Heating Performance Curve

1.5.4.1. BLN-006TC1

A. Heating capacity curve

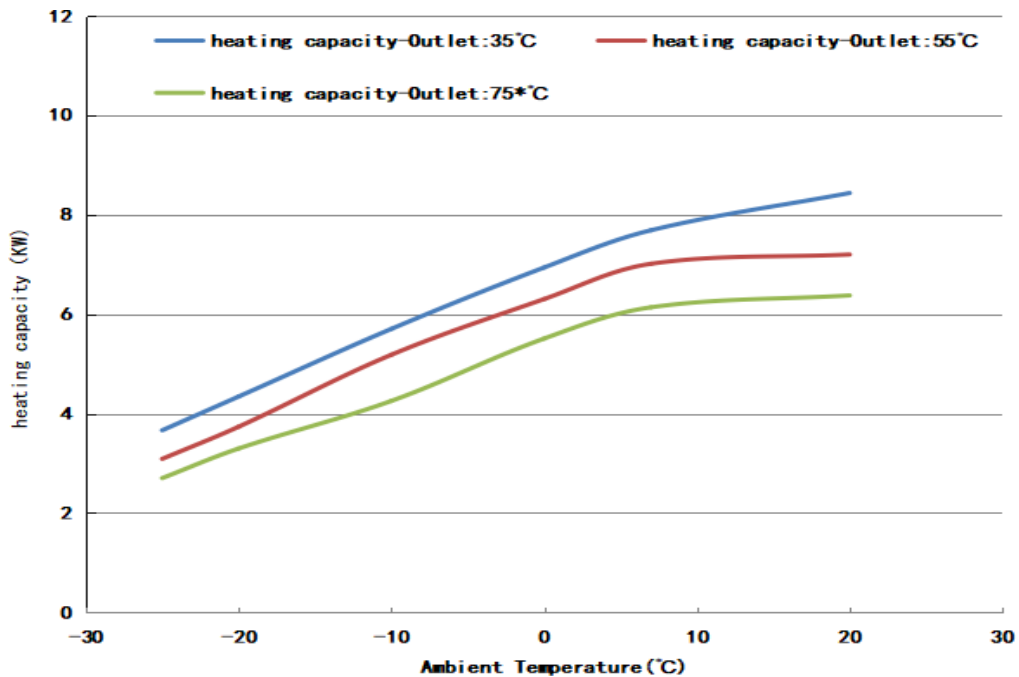

Figure 1-8

B. COP curve

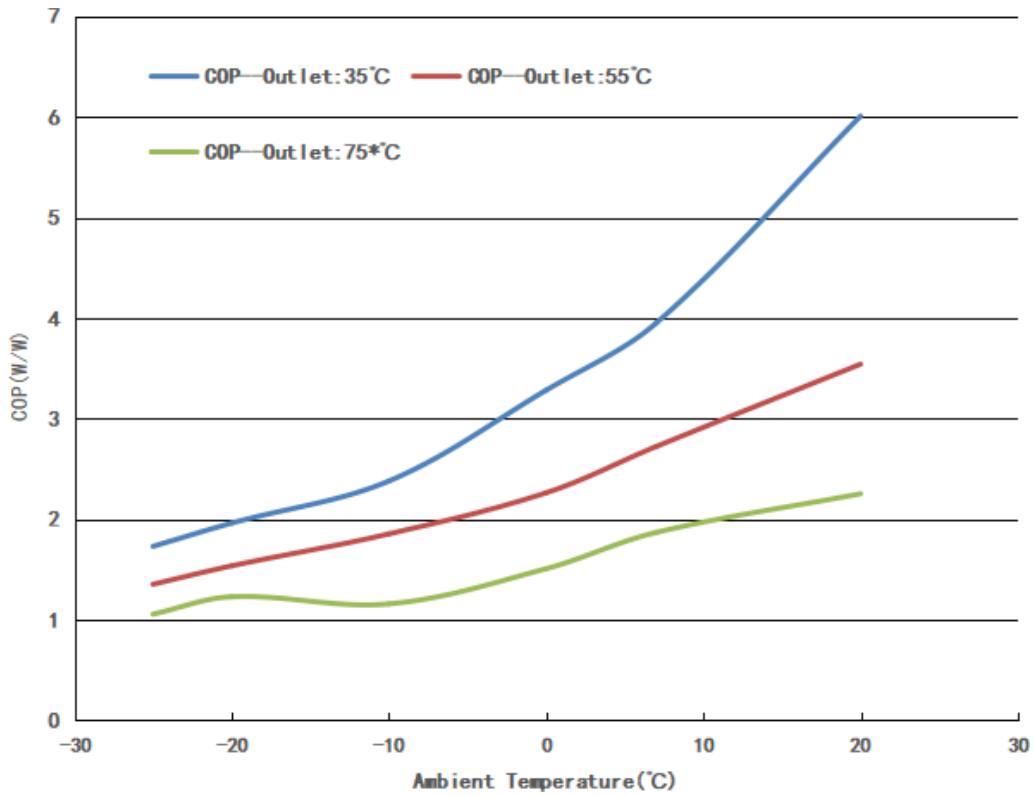

Figure 1-9

C. Heating input power curve

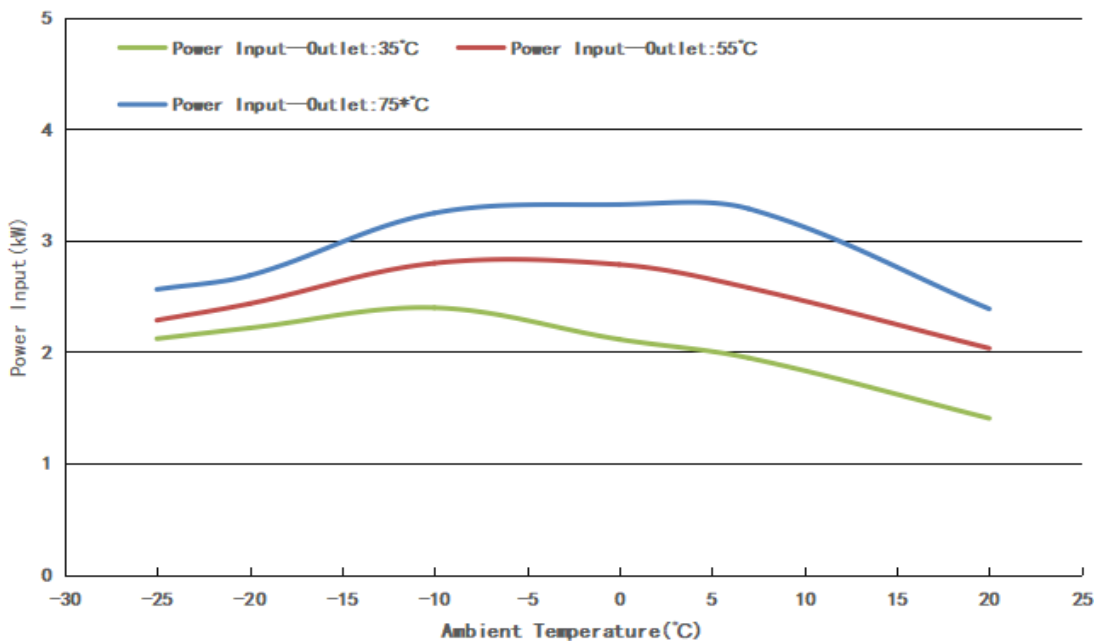

Figure 1-10

Note: *indicates that the ambient temperature of -20°C and the following test data are measured at the outlet water temperature T1565°C.

1.5.4.2. BLN-012TC1/C3

A. Heating capacity curve

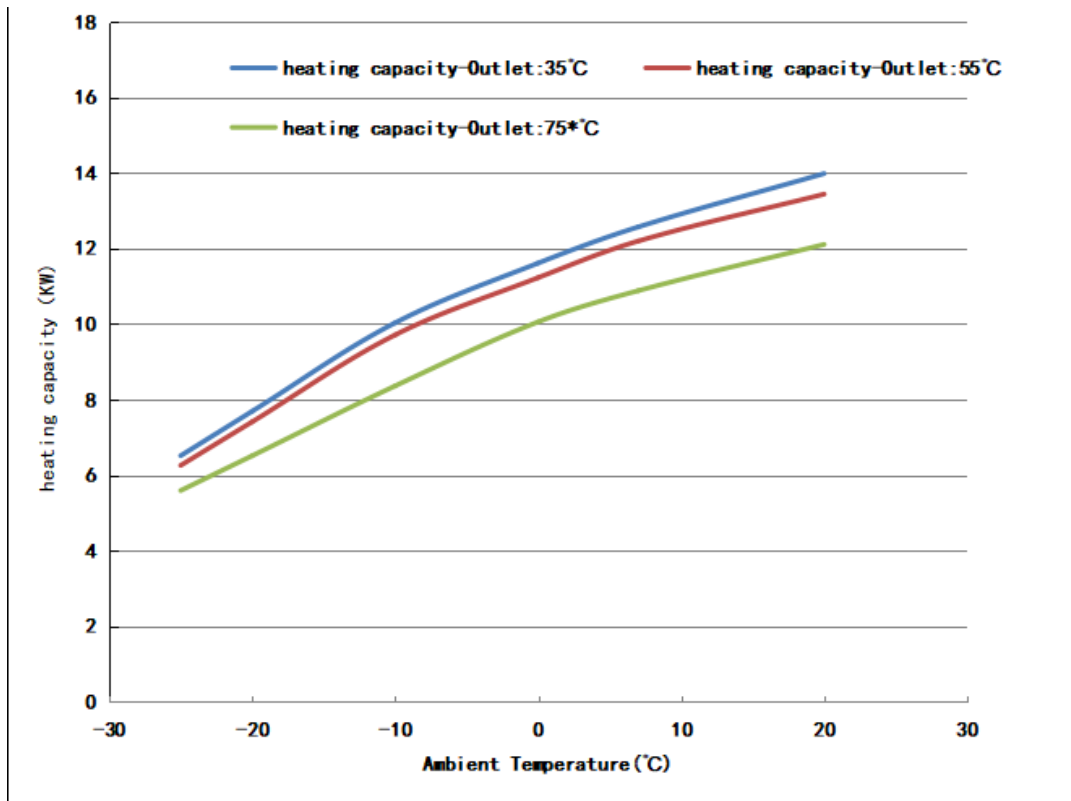

Figure 1-11

B. COP curve

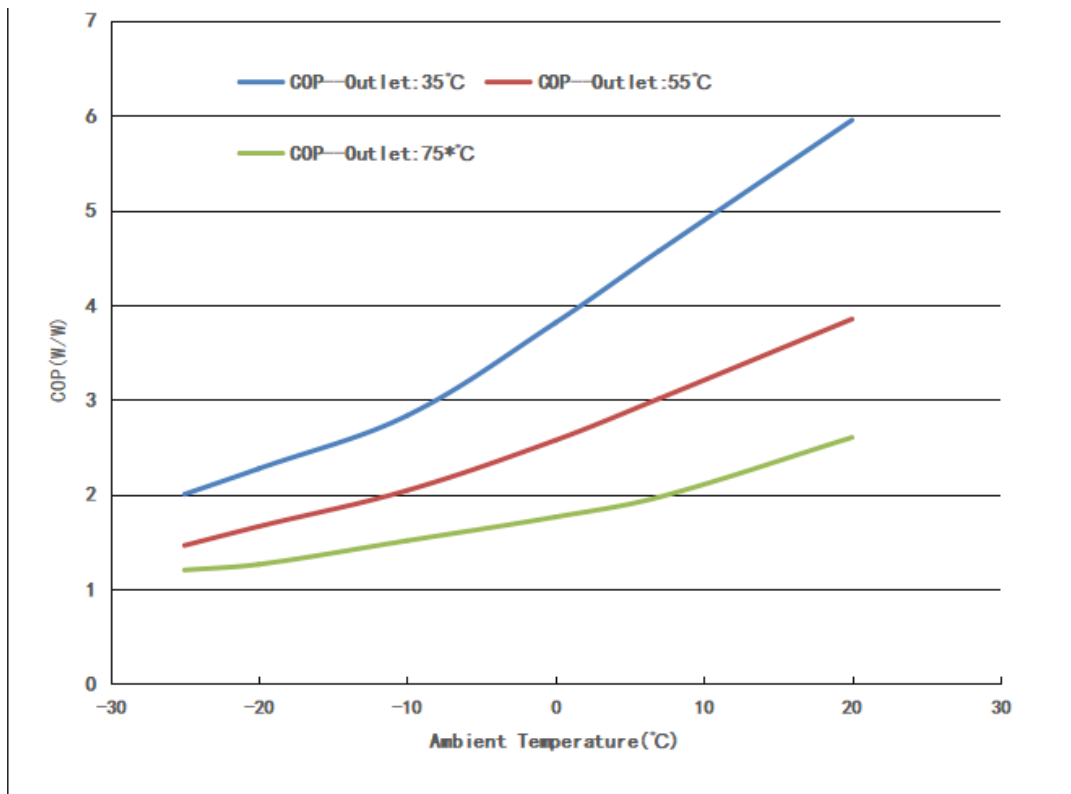

Figure 1-12

C. Heating input power curve

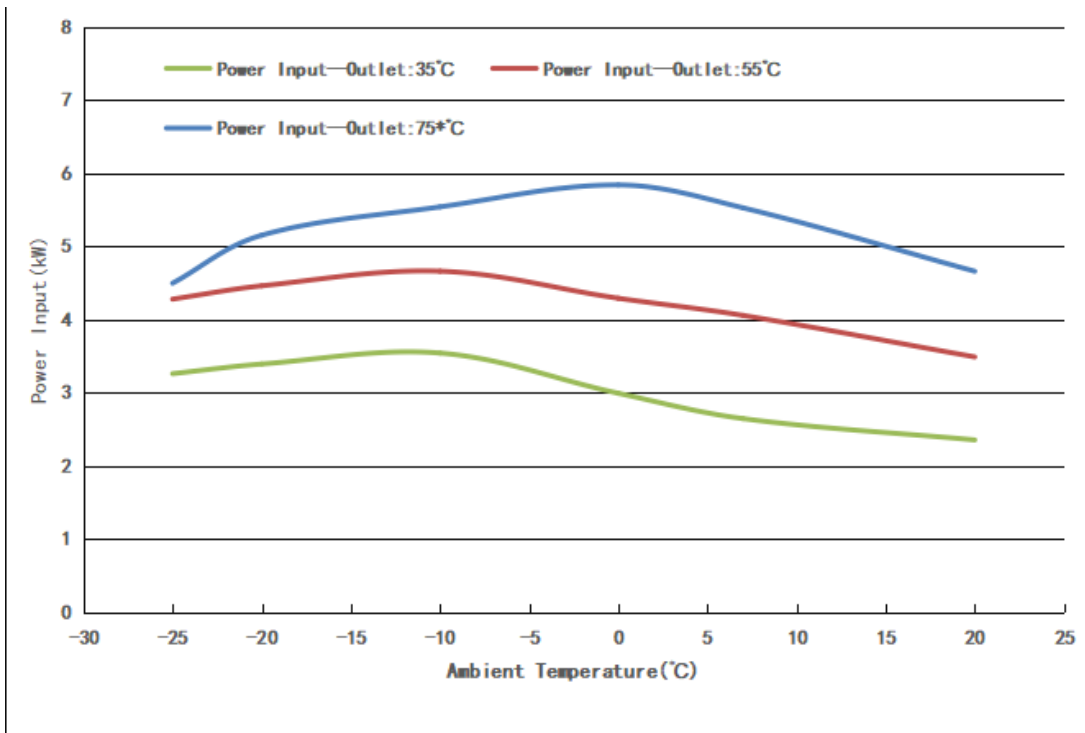

Figure 1-13

Note: *indicates that the ambient temperature of -20°C and the following test data are measured at the outlet water temperature T1565°C.

1.5.4.3. BLN-018TC1/C3

A. Heating capacity curve

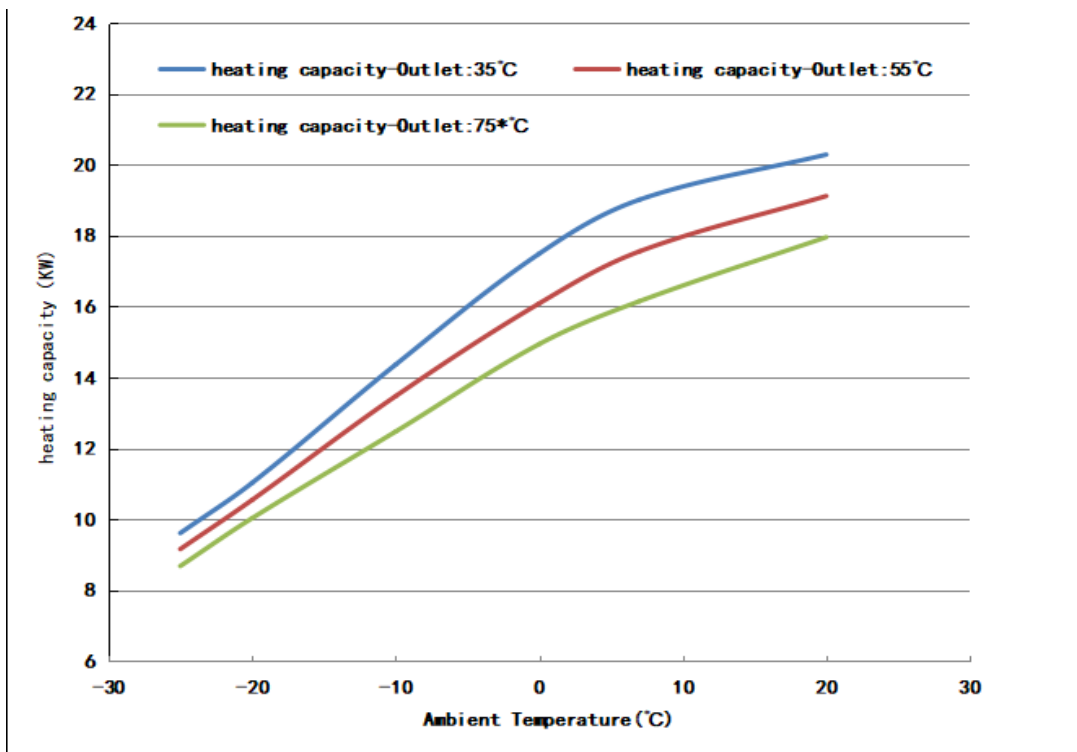

Figure 1-14

ARDEN Heat Pumps Pty

B. COP curve

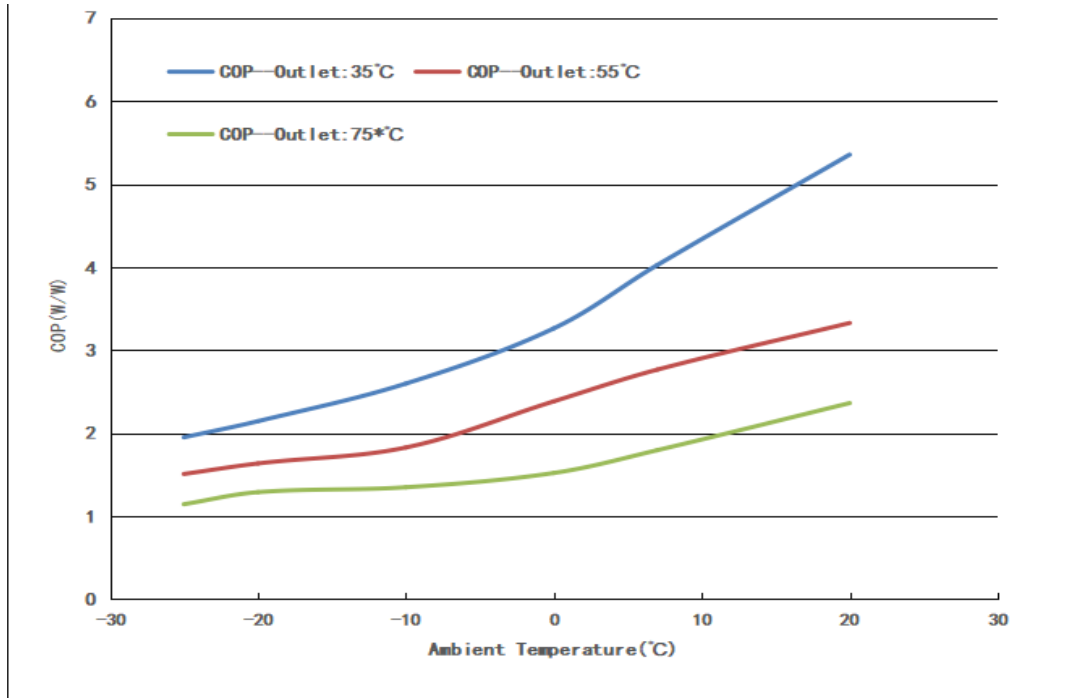

Figure 1-15

C. Heating input power curve

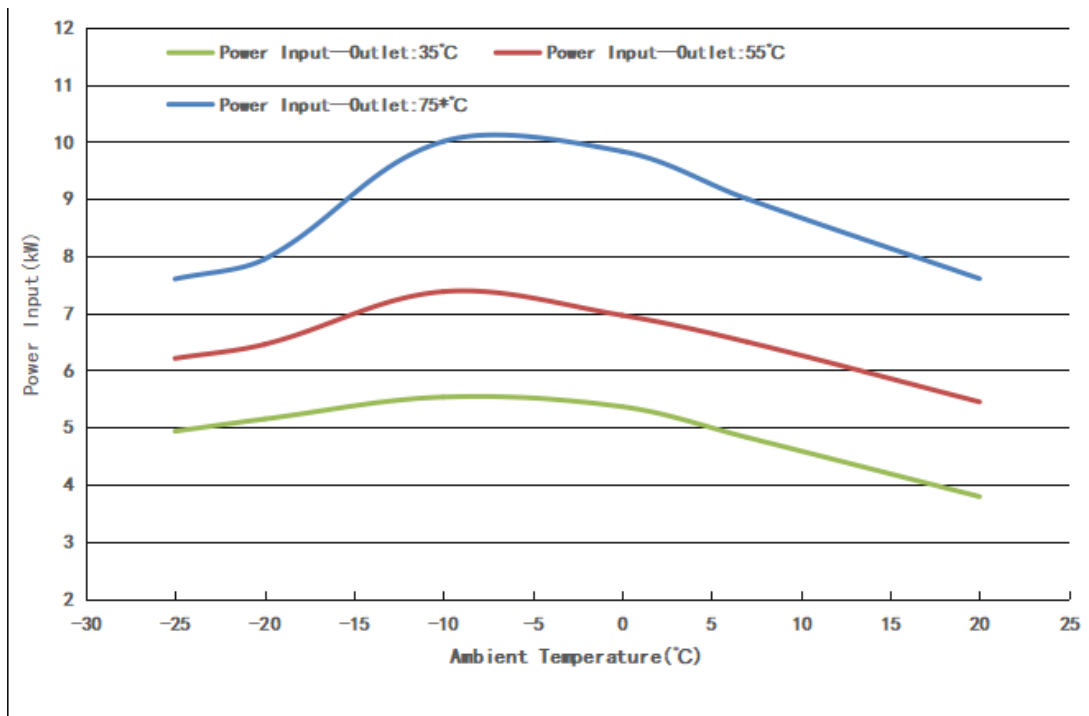

Figure 1-16

Note: *indicates that the ambient temperature of -20°C and the following test data are measured at the outlet water temperature T1565°C.

2. Product selection and installation

2.1. Product installation instructions and special precautions

A. Heat pump cooling and heating and heating water systems should be closed systems. If antifreeze or other refrigerants are used, please consult our company;

B. A filter must be installed before the water inlet pipe of the heat pump unit, and the mesh number of the filter is more than 40 mesh;

C. The filter screen in the filter must be made of stainless steel to prevent impurities from entering the system after the filter screen is corroded and causing scratches on the heat exchanger.

The heat pump uses non-toxic, flammable and explosive refrigerants. When installing, install it in an outdoor ventilated place, away from open flames.

2.1.1. Disclaimer

1) This product must use a copper core power wire that meets the required wire diameter for independent power supply, and the unit must have a reliable grounding wire; if the wiring does not meet the requirements, causing the unit to not work normally, the company will not be responsible for it.

2) When cleaning the unit, it is necessary to stop the machine and cut off the power switch. If the unit is powered on to clean, it will cause electric shock and personal injury, and the company will not be responsible for it.

3) In winter or when the ambient temperature is below 2°C, if the machine is not used for a long time, be sure to drain the water in the waterway and the water tank to prevent the water from freezing and expanding, cracking the waterway and the water tank, and damaging the machine. If the anti-freeze protection of the unit is stopped due to power failure, resulting in cracking and damage to the unit, the company will not be responsible for it.

2.1.2. warning

1) Before installation, it should be confirmed that the grid voltage is consistent with the voltage required by the unit, and whether the carrying capacity of the wires and sockets meets the maximum power requirements.

2) If the stationary appliance is not equipped with a power supply cord and plug, and there is no other device for disconnecting the power supply (its contact spacing provides full disconnection under the condition of overvoltage class III), the fixed wiring for its connection must be configured according to the wiring rules. An all-pole open leakage protection device with a contact opening distance greater than 3mm.

3) Please entrust a dealer or a professional to install it; the installer must have relevant professional knowledge. If you install it by yourself, if you do it wrong, it will cause water leakage, fire, electric shock, injury, etc.

4) The auxiliary items purchased locally must use the products designated by the company;

5) Please follow the regulations of the local electric company when connecting the power supply; confirm whether the grounding is correct, if the grounding is not perfect, it may cause electric shock.

6) When the heat pump unit needs to be moved or reinstalled, please entrust dealers or professionals to operate it; if the installation is not perfect, it may cause unit operation failure, electric shock, fire, injury, water leakage and other accidents.

7) Never modify and repair by yourself. Improper repair will cause water leakage, fire, electric shock, injury and other accidents. Be sure to entrust dealers or professionals to repair.

8) Do not remove any permanent instructions, labels or nameplates on the inside of the heat pump casing or various panels.

2.1.3. Precautions

1) The power wiring must be equipped with a leakage protector with a rated current value not lower than the maximum operating current of the unit, and the grounding must be reliable and kept dry to prevent leakage. Please always check whether the wiring is well matched. If the connection is not good, it will cause overheating and burn out the device, and even cause fire and other personal injury accidents;

2) In places where water may splash and on the wall, the installation height of the power socket shall not be lower than 1.8 meters, and ensure that water will not splash on the socket, and it shall not be installed where children may touch;

3) During the heating period, there may be drops of water dripping from the pressure relief hole of the pressure safety valve, which is a normal phenomenon. If there is a large amount of water leakage, please find a professional to repair it in time. Do not block the pressure relief hole, so as not to cause damage to the heat pump unit and lead to safety accidents. The drain pipe connected to the pressure relief hole should be installed with a downward slope in a frost-free environment;

4) If the unit is equipped with a power cord, the special power cord provided by the manufacturer must be used when the power cord is damaged, and it must be replaced by the manufacturer or its service organization or similar qualified professional maintenance personnel;

5) If the parts of the unit are damaged, please send it to professionals for repair, and use the special repair parts provided by our company;

6) If the heat pump unit has not been used for a long time (more than 2 weeks), hydrogen gas may be generated in the hot water piping system, and hydrogen gas is extremely flammable. In this case, to reduce the risk, it is recommended to turn on the hot water tap for a few minutes before using any electrical appliances connected to the hot water system, If hydrogen is present, there will be an unusual sound like air passing through pipes when the water starts to flow. Do not smoke or light lights near the faucet while it is on.

7) Do not stick fingers, sticks, etc. into the air outlet or air inlet. Due to the high speed of the internal wind rotor, there is a possibility of injury.

8) When an abnormality (burnt smell) occurs, the manual power switch should be cut off immediately, the operation should be stopped, and the after-sales service department of the manufacturer should be contacted. If it continues to operate abnormally, it may cause electric shock or fire.

9) It cannot be installed in places where flammable gas is easy to leak. Once the flammable gas leaks, it may cause a fire around the unit.

10) Confirm whether the long-term use installation foundation is firm. If the foundation is not firm, there may be a fall injury accident.

2.2. Installation

2.2.1. Heat pump installation

Host installation location requirements:

The host can be installed on the ground, roof, special platform or any other place that is easy to install and can bear the weight of the host.

Choose an installation site with good ventilation and smooth exhaust. Do not install the host in a place with pollution and dust, and do not get close to fire sources, power stations and other strong electricity facilities and equipment;

There should be no open flames or overheated heat source facilities and equipment around the host;

The host, the buffer water tank and the domestic hot water tank should be as close as possible to reduce heat loss.

ARDEN Heat Pumps Pty

There should be a downpipe near the main engine to discharge the condensed water generated during the working process, and thermal insulation and heating measures should be taken to prevent the condensed water from freezing and blocking the pipe;

The installation location meets the fire protection requirements; the width of the main operation channel of the heat pump unit is 1.0-1.2m, and the width of the non-main channel is not less than 0.8m. The distance between the outline of the equipment and the switch cabinet or other electrical devices is 1.0m;

When the units are installed adjacent to each other, the distance between the two units should be maintained at 1.0~1.2m, and the base height of the heat pump unit should be more than 0.1m above the ground.

The height of the installation base of the unit shall not be less than 150mm, and shall be greater than the thickness of the local snow accumulation.

The switchgear, control cabinet, etc. are located near the unit and arranged in a centralized manner.

A shock absorber must be installed at the bottom of the unit to prevent vibration from being transmitted to the building.

The water inlet/outlet of the unit and the water supply and return pipes of the water system must be connected flexibly to prevent vibration from being transmitted from the unit to the building.

2.2.2. Auxiliary pump installation

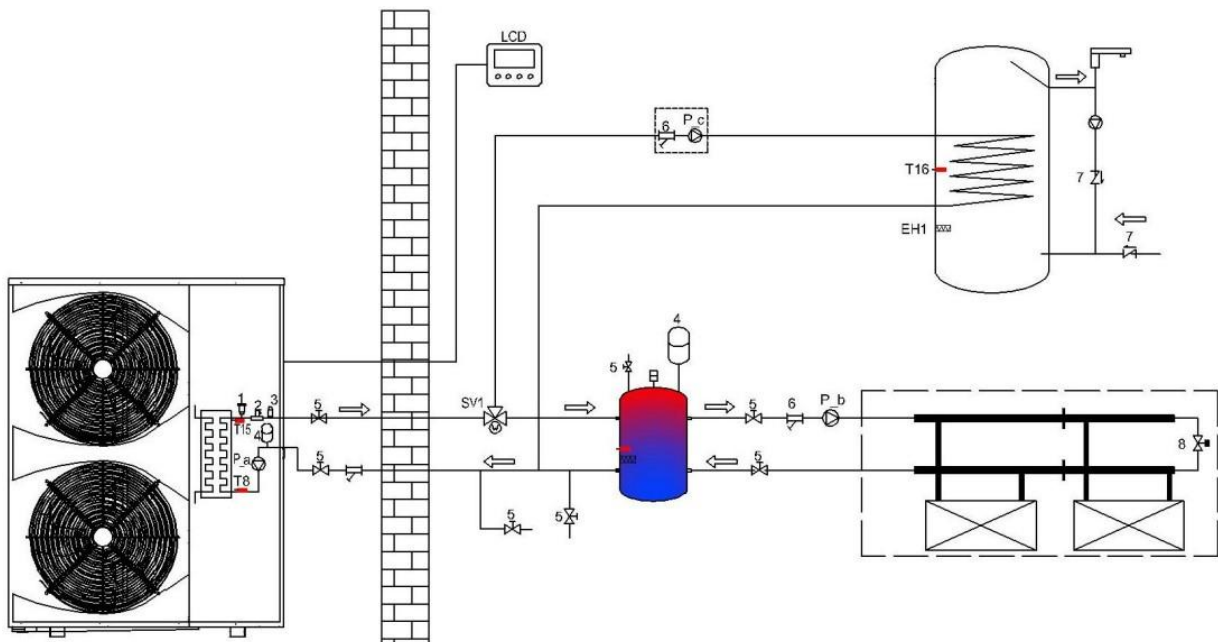

Figure 2-1

Note: For the legend description, please refer to the comparison of the system legend description in Chapter 3 3.4.1

Installation conditions: hot water mode, If the coil water tank is used for secondary heat exchange to heat hot water, the resistance along the process is too large, causing the unit to report a water flow switch failure and unable to start normally. The specific selection needs to be calculated according to the pipeline and the coil of the heat storage tank.

Installation position: Auxiliary water pump Pc circulates the water inlet pipe in the hot water tank, and accesses the control signal from the unit.

2.3. Pipeline installation; water pressure commissioning; pipeline insulation requirements

2.3.1. Water distribution installation system diagram

2.3.1.1. Schematic diagram of waterway system installation

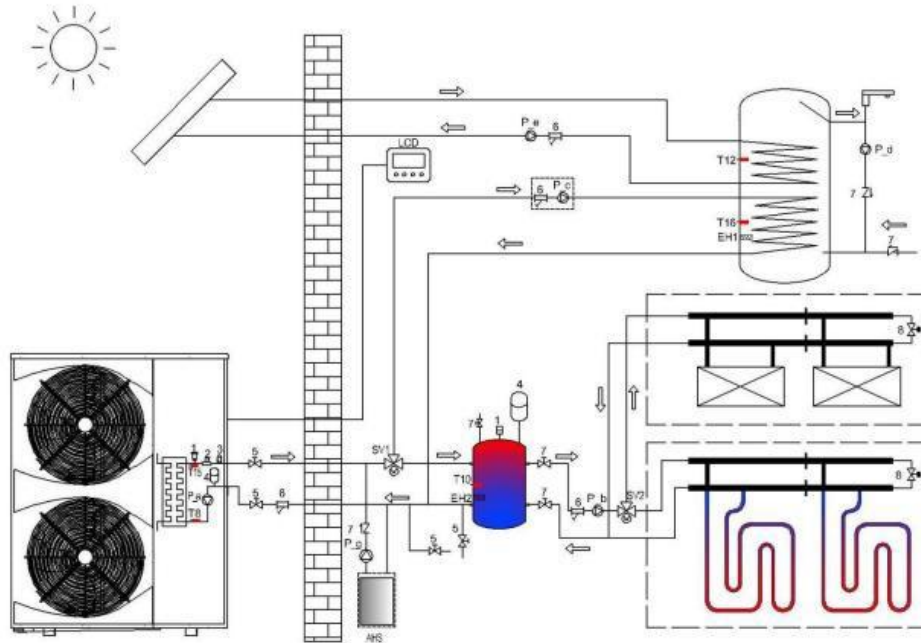

Figure 2-2

Note: For the legend description, please refer to the comparison of the system legend description in Chapter 3 3.4.1

- (1) The pipe running in the same program is conducive to the uniform distribution of water flow;
- (2) The system must be equipped with an automatic replenishment valve, and the highest point of the water system must be equipped with an automatic exhaust valve;
- (3) The drain valve is installed at the bottom of the pipeline, which is conducive to drainage;
- (4) The automatic exhaust valve is installed at the highest point of the system pipeline, and the water pipe at the installation place must have an enlarged diameter;
- (5) The normal working water capacity can ensure normal defrosting in winter (to ensure that the water capacity per KW exceeds 10L);
- (6) There is a water flow switch inside the unit, which does not need to be installed during installation;
- (7) In order to facilitate the maintenance of the unit, a pressure gauge must be installed on the outlet pipe of the unit;
- (8) If the floor heating adopts temperature control by room, and the number of water collectors and distributors in the smallest area is less than or equal to 2, install a differential pressure bypass valve according to the schematic diagram;
- (9) If the unit does not operate in winter, the water inside the system must be drained to prevent freezing of pipelines or components.

2.3.1.2. Water quality requirements

- (1) When the water quality is poor, more sediments such as scale and sand will be produced. Therefore, the used water must be filtered and softened with water softening equipment before flowing into the water system;
- (2) Before using the unit, the water quality should be analyzed, such as pH value, conductivity, chloride ion concentration, sulfur ion concentration, etc.

ARDEN Heat Pumps Pty

The following are the water quality standards applicable to this unit.

pH value	total hardness	conductivity	sulfur ion	chloride ion	Ammonium ion
7~8.5	7~8.5	7~8.5	7~8.5	7~8.5	7~8.5
Sulfate ion	Sulfate ion	Sulfate ion	Sulfate ion	Sulfate ion	Sulfate ion
<50ppm	<30ppm	<0.3ppm	No requirements	No requirements	/

Table 2-1

2.3.1.3. Waterway system installation steps

- (1) Install all water pipes;
- (2) Water pipeline pressure maintenance and leak detection;
- (3) Clean the water pipeline.

2.3.1.4. Water pipeline replenishment and pipeline emptying steps

- (1) First open the exhaust valve and all valves on the water distributor;
- (2) Make up water at the water supply port of the pipeline;
- (3) In the process of replenishing water, it is necessary to observe whether the exhaust valve and the drain valve have water overflowing. If there is water overflowing, it means that the water in the system has been filled;
- (4) Close the exhaust valve, and then look at the water pressure gauge. If the pointer is greater than 0.15Mpa, you can close the water supply valve, and the waterway is completely emptied.

2.3.1.5. Water pressure commissioning and water pressure test shall meet the following requirements

- (1) Before the test, the pipeline should be fixed, the joints should be exposed, and the water distribution equipment should not be connected;
- (2) The pressure gauge is installed at the lowest point of the test pipe section, and the pressure accuracy is 0.01Mpa;
- (3) Slowly fill the pipe with water from the lowest point of the pipe section, fully remove the air in the pipe, and conduct a water tightness test;
- (4) Slowly increase the pressure of the pipeline. It is advisable to use a manual pump for boosting the pressure, and the boosting time should not be less than 10 minutes;
- (5) After increasing the pressure to the specified test pressure, stabilize the pressure for 1 hour, and the pressure drop shall not exceed 0.06Mpa;
- (6) Under the state of 1.15 times of the working pressure, the pressure drop shall not exceed 0.03Mpa

after 2 hours of steady pressure;

- (7) During the test, there must be no leakage at each joint;
- (8) Allow two supplementary pressures within 30 minutes to rise to the specified test pressure.

2.3.1.6. Pipe insulation requirements

- (1) All hot water pipes must be wrapped with insulation materials;
- (2) Wrap the insulation pipe flatly on the hot water pipe and then wrap the cable tie;
- (3) Wrap the insulation skin (such as: thin aluminum plate, aluminum foil, etc.) on the pipe that has wrapped the insulation pipe;
- (4) The wall thickness of the insulation pipe should be reasonably selected according to the local climate. For DN20 pipes, insulation cotton with a thickness of more than 10mm should be used; finally, a layer of wrapping tape should be wrapped on the insulation cotton.

2.4. Precautions for electrical wiring

- (1) Outdoor dedicated power cords should be used, and the power supply voltage should meet the rated voltage requirements;
- (2) The power supply line of the unit must have a grounding wire, and the power grounding wire must be reliably connected to the external grounding wire, and the external grounding is effective.
- (3) The user's incoming power supply must be installed with a leakage protection device.
- (4) The wiring construction must be connected by professional installation technicians according to the circuit diagram.
- (5) The power lines and signal lines should be neatly and reasonably arranged without interfering with each other. At the same time, they should not be in contact with the connecting pipe and valve body, and the minimum distance between strong and weak currents should be more than 25mm.
- (6) The wire controller should be installed in a place where it is easy to observe and operate, and it should not be installed in a place with water and humidity.
- (7) The connecting wires in the host have been installed before leaving the factory, and there is no need to connect them at the user's place. Just check whether the connecting wires are connected normally, whether they are damaged or fall off.
- (8) If the cable connecting the temperature probe and the controller is not long enough, it can be properly lengthened, and the total length should not exceed 20 meters. Note that the connection should be

firmly wrapped and waterproof insulation.

(9) High-voltage side cables: the unit power cord, water pump power cord, electric heating power cord, solenoid valve power cord, etc. must use anti-aging, corrosion-resistant power cords suitable for outdoor use (type H07RN-F or higher).

(10) If the user needs to configure the power cord by himself, please choose a copper core power cord, and the diameter of the copper core power cord should not be less than the following specifications. If the user's power distribution capacity is insufficient or the outdoor power line (copper core line) is not configured as required, resulting in the failure of the unit to start or run normally, the company will not be responsible for it.

IMPORTANT NOTE: Always make sure the heat pump is disconnected from the power supply before doing any electrical installation work.



2.5. Room heat load calculation

2.5.1. basic requirements

The heat load of the heating system in winter shall be determined according to the following heat loss and gain of the building:

- 1) Heat consumption of the enclosure structure;
- 2) Heating the cold air infiltrated into the room from the outer door and window gap consumes heat;
- 3) Heat consumption for heating the cold air that enters the room through the outer door when the outer door is opened;
- 4) Ventilation heat consumption;
- 5) Heat lost or gained through other means.

Note: When calculating the heat load, the infrequent heat dissipation may not be calculated; the hourly average value shall be used for the frequent and unstable heat dissipation. At present, the area of residential buildings is getting larger and larger, the internal heat gain per unit building area is different, and the heat dissipation of cooking, lighting, and household appliances is intermittent. This part of free heat can be used as

a safe amount and will not be considered when determining the heat load. The heat dissipation of larger and more constant exothermic objects in public buildings should be considered when determining the heat load of the ventilation system.

Simple Estimation of Heat Load

The heating load can be recommended as follows:

Climatic conditions	warm climate zone		average climate		cold climate zone	
Calculate climate temperature °C	7		0		-12	
Envelope Insulation	×	√	×	√	×	√
Heating load (W/m ²)	80-100	40-60	100-120	40-60	120-150	40-60

Table 2-3

Note: The heat loss of the pipe network has been included in this heat index, accounting for about 5%;

Note: In some special places (such as glass wall exhibition halls, etc.), the load should be increased as appropriate to ensure the effect.

When calculating the heat load of the comprehensive ground radiation heating system, the calculated indoor temperature should be 2°C lower than the indoor calculated temperature of the convection heating system, or 90% to 95% of the total heat load calculated by the convection heating system. The suitable design indoor temperature is 20°C.

When the floor radiation is used for local area heating of the room and other areas are not heated, the heat dissipation required for floor radiation can be determined by multiplying the heat dissipation required for overall radiant heating by the calculation coefficient in Table 1-2 'Calculation Coefficients of Heat Consumption for Local Radiant Heating'.

Calculation coefficient table for heat consumption of local area radiant heating

Ratio of heating zone area to total room area	≥0.75	0.55	0.4	0.25	≤0.20
Calculation coefficient	1	0.72	0.54	0.38	0.3

Table 2-4

For rooms with a depth greater than 6m, it is advisable to divide the room 6m away from the outer wall, calculate the heat load and arrange the heating components respectively. For the building ground where heating components are laid, the heat transfer heat load of the ground should not be calculated.

When the height of the room (excluding the stairwell) using ground heating is greater than 4m, the height additional rate shall be calculated on the basis of the sum of the basic heat consumption and the sum of orientation, wind force, and additional heat consumption of the external door. 1% should be added for every 1m higher, but the maximum additional rate should not be greater than 8%.

Calculation of ground heat dissipation and system heat supply According to the heat load of the room, the radiation heat dissipation of the floor of the room can be calculated. (The ground area, water temperature, indoor temperature, etc. of laying heating pipes are used to calculate the distance between geothermal pipes).

Heat dissipation required per unit floor area:

$$q_1 = \beta \frac{Q_1}{F_r}$$

$Q_1 = Q - Q_2$

in the formula:

q_1 — Heat dissipation required per unit floor area (W/m^2);

Q_1 — the effective upward heat dissipation required by the room (W);

F_r — the floor area of the room where heating components are laid (m^2);

B — safety factor considering the shelter of furniture etc. (recommended value 1.1-1.2);

Q — room heat load (W), which can be calculated according to the recommended value in Table 1-1;

Q_2 — The heat dissipation loss from the floor of the upper room (W);

For rooms with full ground heating, the heat dissipation per unit area of the ground and the indoor design temperature should make the average temperature of the ground surface required by the room within the appropriate range, and should not be higher than the maximum limit of 28°C. When the calculated value of the local average surface temperature is too high, the following measures can be taken:

Improve the thermal performance of the building envelope;

Add other heating equipment;

Under the condition of satisfying the comfort level, reduce the indoor calculated temperature appropriately.

2.5.2. water system design

Precautions for central heating:

For residential buildings using centralized heat sources, the design of the heating system in the building shall meet the following requirements:

The form of household independent system with shared riser shall be adopted.

The same pair of risers should be connected to indoor systems with similar loads.

The number of households connected by a pair of shared risers on each floor should not exceed 3 households, and the total number of indoor systems connected by shared risers should not exceed 40.

The water supply and return pipes connecting the common standpipe to the indoor system shall be provided with shut-off valves respectively, and one of the shut-off valves shall have an adjustment function, and a static balance valve shall be used.

Shared standpipes and household shut-off and regulating valves should be installed in pipe wells or small rooms in outdoor public spaces.

Household installations such as primary water separators, water collectors, and heat exchangers or water mixing devices for each household should be installed indoors.

Precautions for independent heat source heating:

For indoor systems with independent heat sources, the flow rate and head of the circulating water pump should meet the needs of the indoor heating system; the constant pressure value of the system should meet the pressure requirements of heating pipes or prefabricated thin heating panels.

2.5.3. Distributor and water collector configuration principle

The lengths of the loops of the same pipe diameter connected to the same water separator and water collector should be close to each other.

When laying heating pipes on site, the length of each loop heating pipe should not exceed 120m.

The total length of the water supply and return pipes of each transmission and distribution pipe of the prefabricated light and thin heating board should not exceed 50m.

When there is a large difference in the length of each loop, it is advisable to use heating pipes with different diameters, or set a balance device on each branch loop.

2.5.4. Selection of floor heating heat pump unit

(1) Calculate the design heat load of the room

Room design heat load = additional coefficient × floor heating area × heat load

The additional coefficient is the ratio of the floor heating area to the whole room area, which can be selected according to the following table:

Ratio of heating zone area to	>0.55	0.4-0.55	0.25-0.4	<0.25
additional coefficient	1.0	1.3	1.35	1.5

Table 2-5

Note: The additional coefficients in the above table are standard recommended values, and specific adjustments should be made according to actual conditions in actual engineering.

(2) Check the heat dissipation of the floor

Calculate the heat dissipation of the floor according to the above, and the deviation from the design heat load of the room should not exceed 5%. The main purpose is to calculate whether the heat dissipation can meet the room heat load under the condition that the floor surface temperature does not exceed the limit value.

(3) Determine the heating load of the heat source

The heating load of the heat source is the sum of the heat dissipation from the ground and the heat loss from the ground to the lower layer or the soil. Refer to Appendix A for downward heat loss.

(4) Selection of spectrum

According to the performance curve in 1.5.4 of the model spectrum, multiply the safety factor of 1.1~1.2 to select the appropriate unit.

(5) Selection of floor heating auxiliary accessories

A. Circulating water pump

The basic principle:

- 1) It should satisfy the larger value of flow rate and head required by the design heating condition in winter and cooling condition in summer.
- 2) When the head of the water pump used for the unit is smaller than the system resistance, a series water pump should be added.
- 3) Select the most unfavorable water system loop, carry out hydraulic calculation, and select the circulating water pump according to the total pressure head loss and considering the margin.

B. Pump head

Calculate the resistance loss of the ground heating buried pipe and select the head of the water pump.

The hydraulic calculation formula of the floor heating plastic pipe is:

$$\Delta P = \Delta P_m + \Delta P_j$$

- 1) Calculation of resistance along the way

$$\Delta P_m = R * l$$

- 2) Calculation of local resistance

$$\Delta P_j = \varepsilon \frac{\rho v^2}{2}$$

The relevant parameters can be found out according to the hydraulic calculation table for detailed calculation.

It can also be estimated by the following formula:

Head H=K*(height difference between pipelines h (m) + unit water side pressure loss + longest pipeline length (m) * 0.07)

Note:

- a. K is the value of safety factor 1.1-1.2; single-channel water system takes 1.1, multi-channel water system takes 1.2
- b. The unit of water side pressure loss is kPa, 10kPa=1m (H2O) head;
- c. In the case of the unit with its own water pump, the head of the auxiliary water pump needs to be calculated by subtracting the head of the water pump of the corresponding unit

C. Pump flow

Floor heating pumps are selected according to 1.2 times the total flow of the system.

D. Expansion tank

Basic requirements: anti-rust, also suitable for water/ethylene glycol (up to 30%) solution.

General Specifications:

Expansion tank specifications

Volume (L)	2	4	5	8	12	18	19	20
Preset pressure(bar)	1.5~3	1.5~3	1.5~3	1.5~3	1.5~3	1.5~3	1.5~3	1.5~3
Maximum pressure (bar)	10	10	10	10	10	10	10	10
Interface diameter	3/4"	3/4"	3/4"	3/4"	3/4"	3/4"	3/4"	3/4"
Maximum working temperature (°C)	70	70	70	70	70	70	70	70

Table 2-6

Calculation selection:

$$V = \frac{C \times e}{1 - \frac{P1+1}{P2+1}}$$

In the formula:

ARDEN Heat Pumps Pty

V: the volume of the expansion tank, unit: L

C: The total capacity of water in the system (including boilers, pipes, radiators, etc.), unit: L

e: thermal expansion coefficient of water, see Appendix B of the expansion coefficient table of water at different temperatures for details.

P1: The pre-charge pressure of the expansion tank, unit: bar, this pressure cannot be lower than the static pressure of the system at the installation point of the expansion tank.

P2: The highest operating pressure of the system (that is, the take-off pressure of the safety valve in the system), unit: bar, and the height difference between the expansion tank and the safety valve needs to be considered.

Note: All pressures in the above formula are relative pressures (i.e. gauge pressures), and the selection principle is to select large and not small.

Expansion tank installation instructions

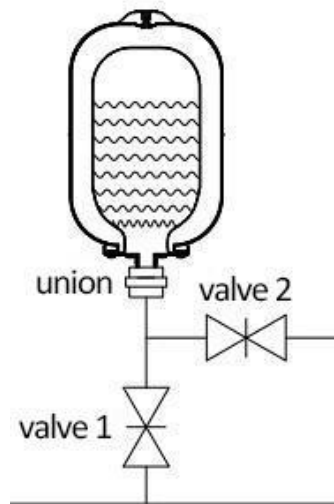

Figure 2-3

E. filter

The water return port of the heat pump unit must be equipped with a water filter, which can reduce impurities in the pipeline from entering the filter and protect the normal energy-saving operation of the unit.

Basic requirements: The material is brass or stainless steel, brass is recommended, the filter is stainless steel, and it is also suitable for water/ethylene glycol (up to 30%) solutions.

General Specifications:

Filter specifications

Interface diameter	1" F	1.1/4" F	1.1/2" F	2" F
Filter mesh	40	40	40	40

Table 2-7

Suggestion for type selection: The function of the filter is to collect the materials in the system to prevent the materials from affecting the normal operation of the system. The larger the mesh number of the filter mesh, the finer the particle size of the material, and the smaller the mesh number, the larger the particle size of the material. The diameter of the filter should be the same as the outer diameter of the main water supply pipe of the system or one specification larger than the outer diameter of the pipe.

Suggestion for installation: When selecting a filter, you must choose a suitable location, and the water flow direction of the system must be consistent with the direction of the arrow on the filter. For a filter with a drain valve, the drain valve must be downwards. Improper installation may result in the inability to remove the garbage in the filter through the drain valve. The long-term retention of these garbage in the filter screen will reduce the effective area of the filter screen, increase the water resistance generated by the filter screen, and reduce the water flow of the system.

F. Safety valve

Safety valves are generally installed in thermal systems such as air conditioners, boilers, heat pumps, etc., and are generally installed at the return water end of the system.

Basic Requirements: Made of brass or stainless steel, also suitable for water/glycol (up to 30%) solutions.

General Specifications:

Safety valve specification

Connection size	1/2"MF	1/2"FF
Set pressure (bar)	1.5/2.5/3	1.5/2.5/3

Table 2-8

Suggestion for type selection: The safety valve plays a role of safety protection in the system. When the system pressure exceeds the specified value, the safety valve opens to discharge part of the hot water in the system, so that the system pressure does not exceed the allowable value, so as to ensure that the system will not cause accidents due to excessive pressure. The set pressure (take-off pressure) of the safety valve is consistent with the maximum working pressure of the system. Generally, refer to the parameters provided by the equipment provider.

G. Electric three-way valve

Basic requirements: in brass, stainless steel or plastic, also suitable for water/glycol (up to 30%) solutions.

Selection suggestion:

ARDEN Heat Pumps Pty

Wiring mode: three wires and two controls;

Driving voltage: AC220V

Action time: 15s

Medium temperature: 2-95°C

Nominal pressure: 1.6Mpa

Wiring instructions:

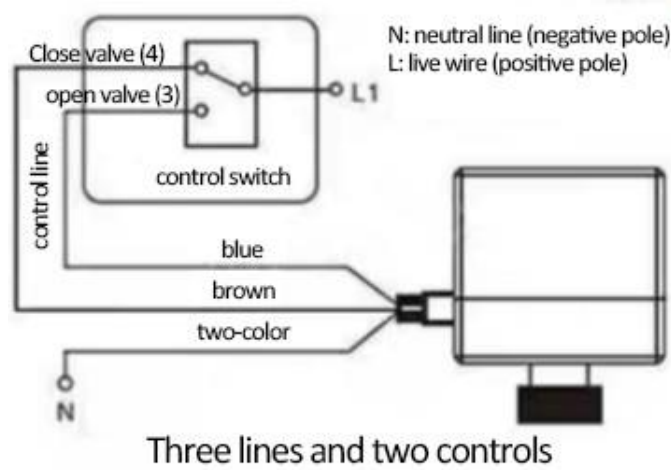

Figure 2-4

H. Filling valve (manual or automatic)

Basic Requirements: Made of brass or stainless steel, also suitable for water/glycol (up to 30%) solutions.

General Specifications:

Fill valve specification

Connection size	1/2"MF	1/2"FF	3/4"M1/2"F	3/4"M1/2"M
Maximum water inlet pressure (bar)	3	3	3	3
Pressure adjustment range (bar)	0.3~3	0.3~3	0.3~3	0.3~3
Factory preset pressure (bar)	1.5	1.5	1.5	1.5

Table 2-9

Suggestion for model selection: The pressure setting of the automatic replenishment valve is 0.3 bar higher than the static pressure, but the set value must be lower than the replenishment pressure (water inlet pressure), otherwise the water cannot be replenished normally.

I. Exhaust valve (manual or automatic (recommended))

Basic Requirements: Made of brass or stainless steel, also suitable for water/glycol (up to 30%)

solutions.

General Specifications:

Exhaust Valve Specifications

Connection size	1/4”M	3/8”M	1/2”M
Maximum working pressure (bar)	8	8	8
Maximum working temperature	90	90	90

Table 2-10

Suggestion for model selection: Because there is usually a certain amount of air dissolved in water, and the solubility of air decreases with the increase of temperature, so that the gas gradually separates from the water during the water circulation, and gradually gathers together to form large bubbles or even air columns. Because of the replenishment of water, gas is often generated. During the operation of the heat pump system, many adverse effects caused by the gas released when the water is heated, such as oxygen, will damage the system and reduce the thermal effect. If these gases cannot be discharged in time, many adverse consequences will occur.

J. Type selection of buffer water tank

The water heating system needs to consider the influence of the system water capacity on the system stability. For the air source heat pump heating system, the biggest influencing factor is the defrosting of the unit in winter. The defrosting time of the air source heat pump unit is 3-8 minutes, and the defrosting time of 4 minutes is used to calculate the volume of the energy storage water tank. During winter operation, the defrosting time of the main engine is 4 minutes, and the water supply temperature is allowed to drop by no more than 3°C.

Install a buffer water tank on the return water main pipe of the water system to buffer the temperature fluctuation of the water system. The buffer water tank adopts the pressure-bearing type, the maximum working pressure is ≥7bar, and the size of the nozzle is in accordance with the size of the main pipe.

Selection calculation:

Total water volume of heating system:

$$V1=Q*t/(C*\Delta T)$$

In the formula:

Q -----Rated heat output for the unit, unit kW;

ΔT-----Water temperature drop, unit °C, generally take 3 °C;

t -----unit defrosting time, take 240s

ARDEN Heat Pumps Pty

C----- The specific heat of water is 4.2 (kJ / (kg·°C))

Water volume in the heating pipeline:

$$V_2 = \pi \cdot d^2 \cdot L / 4000$$

π ----- is the pi constant, get 3.14;

d----- pipe inner diameter, unit m;

L----- The total length of the pipeline is subject to the actual engineering installation, and the unit is m

Buffer tank capacity: $V = V_1 - V_2$

Buffer water tank selection recommendation table

Model	BLN-006TC1	BLN-012TC1/C3	BLN-018TC1/C3
Heating water tank recommended capacity L	50-70	80-100	100-150

Table 2-11

K. Selection of hot water tank

hot water tank capacity calculation,

$$V = Q \cdot t \cdot 3600 / (C \cdot \Delta T)$$

In the formula:

Q ----- Rated heat for the unit, unit kW;

t ----- The heating time of the unit is 1-2h, it is recommended to take 1.5h to prevent the use of hot water or heating;

ΔT ----- Hot water temperature difference, unit °C, generally take 40 °C;

C----- The specific heat of water is taken as 4.2 (kJ / (kg·°C))

V----- water tank volume, unit L

L. Type selection of inner coil of hot water tank

Household hot water is usually heated by built-in coils, so the specification selection of the inner coils directly affects the heating effect and unit operation reliability.

The specifications of the built-in coil are as follows:

material		Stainless steel SUS316L			20# steel + outer surface enamel		
Diameter	light pipe	22	28	32	22	28	32
	Bellows	22	28	32	/	/	/

Table 2-12

Selection calculation: According to experience, the heat transfer per unit area q of the light tube is 3kW,

and the heat transfer per unit area q of the bellows is 6KW.

$$S=Q/q$$

In the formula:

S is the outer surface area of the inner coil in m^2 ;

Q is the rated heating capacity of the unit;

q is heat transfer per unit area kW/m^2

$$\text{Coil length: } L=S/(\pi*d)$$

In the formula:

S is the outer surface area of the inner coil in m^2 ;

π is the constant of pi;

d is the pipe diameter in m

Calculate the appropriate tube length according to the above formula.

Note: If the corrugated inner coil is used, the resistance loss of the water system will increase. Please pay attention to the reasonable adjustment of the head of the circulating water pump.

M. water pump connection diagram

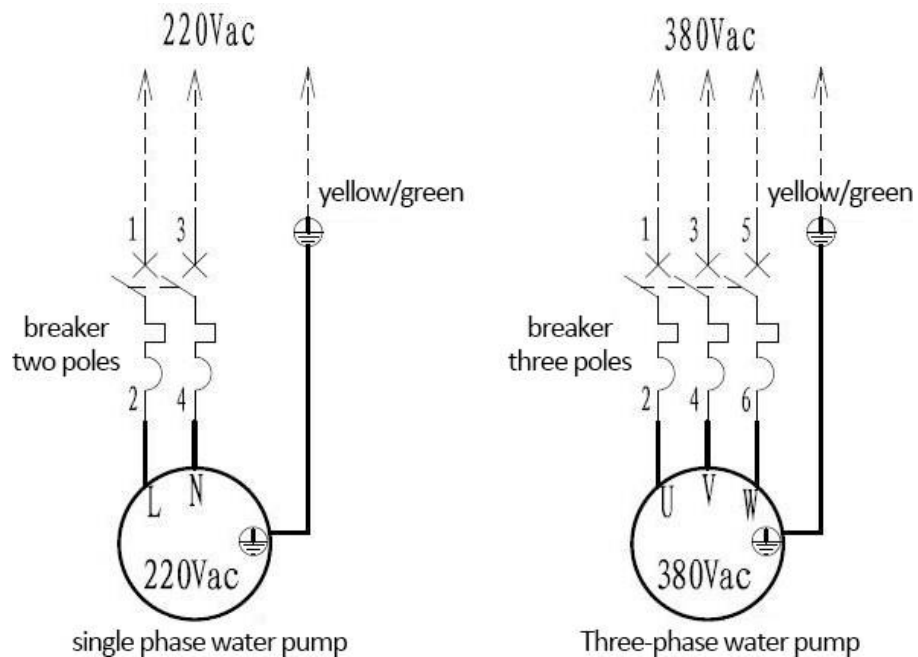

Figure 2-5: water pump connection diagram

Type selection: rated current of circuit breaker (C/D series) $\approx 1.2*$ rated current of water pump

Copper core power cord:

choose 1.5mm² below 5A

5A~12A choose 2.5mm²

12A~20A choose 4mm²

N. Water quality requirements (refer to "Technical Regulations for Water Quality and Anticorrosion of Heating Systems"):

Requirements for water quality		add water	Recycled water
suspended matter mg/l		≤5	≤10
PH(25°C)	steel equipment		10-12
	copper equipment	≥7	9-10
	aluminum equipment		8.5-9
total hardness	mmol/L	≤6	≤0.6
dissolved oxygen	mg/L	--	≤0.1
oil content	mg/L	≤2	≤1
Chloride CL-mg/l	steel equipment	≤300	≤300
	AISI 304 stainless steel	≤10	≤10
	AISI 316 stainless steel	≤100	≤100
Sulfate SO ₃	copper equipment	≤100	≤100
	aluminum equipment	≤30	≤30
	mg/L	--	≤150
total iron	generally	--	≤0.5
	aluminum equipment		≤0.1
total copper	generally	--	≤0.5
	aluminum equipment		≤0.02

Table 2-13

a. During the operation of the heat pump unit, the water quality needs to be sampled and analyzed regularly (suggested every six months). If the water quality is not up to standard and the heat exchanger and pipeline are damaged, all consequences shall be borne by the user;

b. Precautions for adding antifreeze (it is strictly forbidden to use highly corrosive antifreeze such as methanol blending solution)

When choosing antifreeze, pay attention to the lower local temperature and ensure that the freezing point of the antifreeze is lower than the outdoor temperature;

Appropriate amount should be used in the process of adding. Antifreeze is mostly corrosive, and excessive use will affect the heat transfer performance of the unit, so in the case of meeting the antifreeze performance, the lower the concentration, the better.

It is not suitable to mix them. Try to use the same brand of antifreeze. Even if the main components of different types of antifreeze are the same, their additive formulas will be different, and they should not be mixed to avoid chemical reactions, precipitation or bubbles.

Pay attention to the usage time. Generally speaking, the use time should not be too long, and it needs to be replaced regularly. It is recommended to change it once a year. Use pure water in summer and use new antifreeze in winter.

2.6. *Waterway antifreeze protection

Freezing can damage the circulatory system. Since outdoor units may be exposed to sub-zero temperatures, care must be taken to prevent the system from freezing. All internal fluid circulation parts are insulated to reduce heat loss. Insulation must also be added to field piping.

In the event of a power failure, the device's own frost protection is disabled. **Because of the potential for power outages when left unattended, suppliers recommend using antifreeze in the water system.**

Based on the expected minimum outdoor temperature, ensure that the water system is injected with the concentration of ethylene glycol shown in the table below. When glycol is added to the system, the performance of the unit will be affected. Correction factors for system specific capacity, flow and pressure drop are listed in the table

Ethylene glycol concentration (%)	Correction factor				freezing point “°C”
	cooling capacity	power input	resistance	water flow	
0	1.000	1.000	1.000	1.000	0
10	0.984	0.998	1.118	1.019	-4
20	0.973	0.995	1.268	1.051	-9
30	0.965	0.992	1.482	1.092	-16

Table 2-14

Propylene Glycol Concentration (%)	Correction factor				freezing point “°C”
	cooling capacity	power input	resistance	water flow	
0	1.000	1.000	1.000	1.000	0
10	0.976	0.996	1.071	1.000	-3
20	0.961	0.992	1.189	1.016	-7
30	0.948	0.988	1.380	1.034	-13

Table 2-15

Uninhibited ethylene glycol becomes acidic under the influence of oxygen. The purity and higher temperature of the copper accelerates this process. Glycol, which is unchecked in acidity, can attack metal surfaces and form galvanic corrosion cells, which can cause serious damage to the system. This is extremely important:

- (1) Water treatment is properly performed by qualified water experts.
- (2) Choose ethylene glycol containing corrosion inhibitors to offset the acid formed by the oxidation of ethylene glycol.
- (3) **If a domestic hot water tank is installed, only propylene glycol is allowed.** In other installations, the use of ethylene glycol is also acceptable.
- (4) Do not use automotive ethylene glycol, because their corrosion inhibitors have limited life and

ARDEN Heat Pumps Pty

contain silicate, which will pollute or block the system;

(5) Galvanized pipes are not used in glycol systems because it may cause precipitation of certain elements in glycol corrosion inhibitors;

(6) Make sure the glycol is compatible with the materials used in the system.

3. Electrical operation

3.1. Control

3.1.1. out of service

The outage occurs for the following reasons:

- (1) Abnormal shutdown: In order to protect the compressor, if there is an abnormal state, the controller interface will display the system error code.
- (2) When the set temperature is reached, the system stops running.

3.1.2. DC water pump control (PWM)

(1) When the unit is started, the water pump Pa is turned on; when the unit reaches the temperature and stops, the control is as follows:

When the Pa water pump is fully turned on with 100% duty cycle for 2 minutes, enter the water pump speed regulation. When the temperature difference $>P99+3$ or the water flow $<P163$, the Pa pump output is increased by 2%/40S. When the temperature difference $<P99-1$ and the water flow $>P163$, the output of the Pa water pump decreases by 2%/40S:

a. Factory parameter P28 = 0: the water pump continues to run when the temperature reaches the shutdown, the water pump speed drops to 30%, and the water flow meter or water flow switch signal is not detected.

When there is a start signal, the speed of the water pump rises to 99%, and the water flow or water flow switch is detected after 30 seconds.

b. Factory parameter P28 = 1: When the temperature reaches the stop, the Pa water pump will stop after the compressor stops for 60 seconds; it will run for 2 minutes at intervals of 10 minutes;

c. Factory parameter P28 = 2: Pa water pump continues to run when the cooling reaches temperature, and other modes run when P28 = 1;

d. Factory parameter P28 = 3: Pa water pump continues to run when cooling and heating reaches temperature, and other modes run as P28 = 1;

e. Factory parameter P28 = 4: Pa water pump continues to run when the floor heating reaches temperature, and other modes run when P28 = 1;

(2) When the unit is shut down, the water pump will stop after the compressor stops for 60 seconds;

(3) When the water flow switch of the unit is disconnected or the water flow is too low protection E03, the Pa water pump stops;

(4) During defrosting and anti-freezing mode, the Pa water pump remains fully open;

3.1.3. Start control

3.1.3.1. Compressor start condition

After the compressor is started, it must meet the mandatory operation for 3 minutes (parameter P103) before allowing constant temperature shutdown/combination mode switching, and the compressor will not be shut down due to changes in the inlet water temperature T8/hot water tank temperature T16 within 3 minutes after starting.

(1) Heating mode  or floor heating mode 

When **【P116】** = 0, start and stop according to the inlet water temperature T8.

If the ambient temperature \geq heating start limit [P106] 30°C, the unit is not allowed to start, otherwise

judge as follows:

Unit inlet water temperature $T8 < \text{heating set temperature} - \text{return difference}$ [P26] or [P27], if there is capacity demand, the unit must be started;

When the parameter [P:37]=0, the unit inlet water temperature $T8 \geq \text{heating set temperature}$, and the compressor is at the lowest frequency and continues to run for $\geq 5\text{min}$, the unit reaches the temperature and stops;

When the parameter [P:37]=0, the unit inlet water temperature $T8 \geq \text{heating set temperature} + 3$, the unit reaches the temperature and stops;

When the parameter [P:37]=1, the unit inlet water temperature $T8 \geq \text{heating set temperature} + 0$, the unit reaches the temperature and stops;

When 【P116】=1, it starts and stops according to the outlet water temperature T15, and the others are the same as above.

Start-up condition: outlet water temperature $T15 < \text{heating set temperature} - \text{return temperature} - \Delta T$, $\Delta T = \text{difference before shutdown}$ (absolute value range: $1 \leq \Delta T \leq 12$), and outlet water temperature $T15 < \text{heating set temperature}$;

When P26 and P27 are set to 0, hysteresis temperature = $X/10$, X = inlet water temperature T8, range value $2 \leq \text{start-stop hysteresis} \leq 5$.

For example: 35°C inlet water temperature T8 before shutdown, hysteresis temperature = $35/10 = 3.5^\circ\text{C}$, the calculated value is rounded, the actual hysteresis is calculated as 3°C , 60°C inlet water temperature T8 before shutdown. Hysteresis temperature = $60/10 = 6^\circ\text{C}$, the actual start-stop hysteresis is calculated as 5°C (the maximum range value is 5°C).

(2) Hot water mode

(1) The external ambient temperature $T7 \geq \text{hot water start limit}$ [P107] 50°C , the unit is not allowed to start, otherwise judge as follows:

(2) The temperature of the hot water tank $T16 < \text{the set temperature of hot water} - \text{the return difference}$ [P96], if there is capacity demand, the unit must be started;

(3) The temperature of the water tank of the unit is $T16 \geq \text{the set temperature of the hot water}$, and the unit stops when the temperature is reached;

(3) Cooling mode

(1) When the external ambient temperature $T7 \leq \text{cooling start limit}$ [P105] 15°C , the unit is not allowed to start, otherwise judge as follows:

(2) If the inlet water temperature of the unit is $T8 > \text{refrigeration set temperature} + \text{hysteresis value}$ [P26], the unit must be started;

(3) When the parameter 【P37】=0, the inlet water temperature of the unit is $T8 \leq \text{refrigeration set temperature}$, and the compressor is kept running at the lowest frequency for ≥ 5 minutes, and the unit reaches the temperature and stops;

(4) When the parameter [P37]=0, the unit inlet water temperature $T8 \leq \text{refrigeration set temperature} - 3$, the unit reaches the temperature and stops;

(5) When the parameter [P37]=1, the unit inlet water temperature $T8 \leq \text{refrigeration set temperature} - 0$, the unit reaches the temperature and stops;

When 【P116】=1, start and stop according to the outlet water temperature T15, the starting condition

ARDEN Heat Pumps Pty

increases "outlet water temperature $T_{15} > \text{refrigeration set temperature} + \text{hysteresis temperature} + \Delta T$, ΔT = the difference before shutdown (absolute value), and the outlet water temperature $T_{15} > 5^{\circ}\text{C}$ " and other controls are the same.

When P26 and P27 are set to 0, hysteresis temperature = $5 - X/10$, X = inlet water temperature T_8 , range value $2 \leq \text{start-stop hysteresis} \leq 5$

3.1.3.2. Compressor off condition

- (1) The outdoor unit has a shutdown failure;
 - (2) The outdoor unit receives the shutdown command;
 - (3) Compulsory stop command when the unit turns to mode;
 - (4) The unit has no capacity demand, and the temperature reaches the shutdown.
- If any of the above conditions are met, the compressor will stop running.

3.1.3.3. Compressor operating frequency control

- (1) The compressor starts up to 45Hz for 3 minutes at the first start, and then switches to automatic frequency control.
- (2) Compressor frequency reduction or normal shutdown control: the compressor frequency will drop to 30Hz at a cycle of 1Hz/1 second, and then stop running.
- (3) After the compressor is turned off, it must be delayed for at least 3 minutes before it can be turned on, and there is no 3-minute delay when it is powered on for the first time;

3.1.3.4. Compressor temperature shutdown control method

(1) Heating mode

When the parameter [P:37]=0, the outlet water temperature T_{15} or inlet water temperature $T_8 \geq \text{heating set temperature}$, and the compressor is running at the lowest frequency continuously for ≥ 5 minutes, the outlet or inlet water temperature $\geq \text{heating set temperature} + 3$, the unit stops .

When parameter 【P37】=1, the outlet water temperature T_{15} or inlet water temperature $T_8 \geq \text{heating set temperature}$, the unit stops.

When parameter 【P37】=2, cooling is controlled according to parameter 【P37】=0, and floor heating is controlled according to parameter 【P37】=1.

(2) Hot water mode

When the temperature of the hot water tank $T_{16} \geq \text{the set temperature of the hot water}$, the unit stops and there is no constant temperature mode.

(3) Cooling mode

When the parameter [P37]=0, the outlet water temperature T_{15} or inlet water temperature $T_8 \leq \text{refrigeration set temperature}$, and the compressor keeps running at the lowest frequency for ≥ 5 minutes, the outlet or inlet water temperature $\leq \text{refrigeration set temperature} + 3$, the unit stops.

When parameter 【P37】=1, the outlet water temperature T_{15} or inlet water temperature $T_8 \leq \text{refrigeration set temperature}$, the unit stops.

ARDEN Heat Pumps Pty

When parameter 【P37】 =2, cooling is controlled according to parameter 【P37】 =0, and floor heating is controlled according to parameter 【P37】 =1.

Note: When parameter P116=1, the unit is controlled by the outlet water temperature T15; when parameter P116=1, the unit is controlled by the inlet water temperature T8.

3.1.4. High temperature sterilization

(It is valid when parameter P140=0 hot water electric heating is enabled)

Only valid in hot water mode, sterilization function selection: 【L12】=0, automatic; 【L12】=1, disabled; 【L12】=2, manual.

A. When automatic control is selected, it will automatically judge and enter according to the following conditions:

- (1) Sterilization interval days [L13], default: 7 days, counting from the first power-on of the unit;
- (2) Sterilization start time [L14], default: 23:00;
- (3) Sterilization running time [L15], default: 10min;
- (4) Sterilization temperature setting [L16], default: 70°C.
- (5) When the unit is in the air-conditioning mode, shut down or standby, it is all switched to the hot water mode, and the switch of the compressor and the hot water electric heating is determined according to the temperature of the water tank;
- (6) When the temperature of the hot water tank is $T16 < 50^{\circ}\text{C}$, the compressor is turned on, and the hot water electric heating is turned on;
- (7) When the temperature of the hot water tank is $T16 \geq 50^{\circ}\text{C}$, the compressor is turned off. After the compressor is turned off, it will turn to normal operation. If it is in the heating mode before entering the antivirus, it will return to the heating mode, and the temperature of the water tank will continue to work by the electric heating of the water tank. ;
- (8) When the temperature of the hot water tank $\geq [L16]$, the hot water electric heating is turned off, and the time is recorded, and when the time is $\geq [L15]$, the sterilization mode is exited.
- (9) Exit the sterilization mode when the continuous operation time of antivirus exceeds three hours.

B. 【L12】 =2, in manual control, press and hold the switch + timer + down key at the same time to enter.

3.1.5. Silent mode ☺

Operate according to the maximum frequency limit of the silent compressor [P88] 50Hz and the maximum frequency limit of the static fan [P89] 40Hz.

Note: fan speed = [P89] * 15

3.1.6. Waterway emptying mode/forced open water pump

In the off state, long press "On/Off" + "△" + "▽" for 5s to enter; press again or directly press "On/Off" to exit. LCD display: The water pump icon flashes.

Note: 100% output of DC water pump.

3.1.7. Forced defrost ❄️

In the heating, floor heating or hot water mode and the external coil temperature $T1 < \text{exit defrosting coil temperature (parameter P36)}$, press and hold the "M"+"▽" key for 5 seconds to enter defrosting forcefully.

3.1.8. Linkage control

- (1) When P05=1, the linkage switch DI6 is disabled, and the unit starts and stops according to the normal

control of the wire controller:

(2) When P05=0, if the linkage switch DI6 is off, the unit is not allowed to start; if the linkage switch DI6 is on, it will start and stop according to the water temperature;

(3) When P05=2, if the linkage switch DI6 is disconnected, the unit is on standby, and the three-way valve and water pump are controlled by constant temperature shutdown; if the linkage switch DI6 is closed, the machine starts and stops according to the water temperature;

(4) When P05=3, linkage switch DI6 is only valid in heating, floor heating and cooling modes, and invalid in hot water mode

Note: The heat pump linkage switch is a dry contact signal, indicating two states on the electrical switch, including closing and opening. There is no polarity between the two contacts of the dry contact and can be interchanged.

3.1.9. Refrigerant recovery function

In shutdown state or cooling mode, press and hold "On/Off" + " \triangle " for 5s to enter; press "On/Off" to exit.

LCD display: the refrigeration icon flashes, and the temperature zone displays the low pressure temperature value.

3.1.10. Expiry date password setting

In the unlocked state, press and hold 5 buttons simultaneously for 5 seconds until there is a "beep" to enter the password input of the usage period. At this time, the password "0000" is displayed in the temperature zone. You can press the " \triangle " or " ∇ " key to enter the password, and then press "M" to switch to the next password input. After entering the 4-digit password, press the "M" key to confirm. If the password is correct, enter the time limit setting. At this time, the clock area displays the previous setting value, the default is "0 days", the range is 0-360 days, press the " \triangle " or " ∇ " key to adjust, and then press "M" to confirm. Return to the main interface, press and release the " " key immediately or if there is no key operation within 60 seconds, it will automatically return to the normal display state, and the set value will not be saved. The factory default password is 8563. When the running time of the unit meets the usage limit, the wire controller will display E11. If you need to cancel the limit, set the usage limit time to "0" days.

3.1.11. Electric heating control EH1/gas control signal output

When parameter P140=0, hot water electric heating EH1 is enabled

- A. After the unit enters the hot water secondary antifreeze, turn on the hot water electric heating EH1.
- B. When the unit is not in antifreeze state, when it is turned off or turned on for cooling or not for hot water mode, the hot water electric heating EH1 will stop.
- C. The unit has no shutdown fault protection:
 - (1) Hot water electric heating EH1 startup conditions: When the following conditions are met at the same time, hot water electric heating EH1 is started.
 - 1) The outdoor ambient temperature $T7 \leq$ the set ambient temperature of hot water electric heating (parameter P22, default -7), when the outdoor ambient temperature T7 sensor fails, this item is invalid;
 - 2) Hot water tank temperature $T16 <$ set temperature - hysteresis difference (parameter P96).
 - (2) Stop condition of hot water electric heating EH1: meet any of the following conditions, stop hot water electric heating EH1
 - 1) When the outdoor ambient temperature $T7 \geq$ the set ambient temperature of hot water electric heating + 3°C, this item is invalid when the outdoor ambient temperature T7 sensor fails;
 - 2) Hot water tank temperature $T16 \geq$ set temperature.

When the parameter P139=2 and P140=2 enable AHS gas control, the hot water electric heating signal becomes AHS gas control signal output. (Version 3.6.7 and above are valid.)

A. In heating/floor heating mode :

(1) When the ambient temperature is $\leq P21$, it is prohibited to start the heat pump and turn on the gas water heater.

Buffer water tank temperature $T10 < \text{heating heat source setting temperature} - \text{temperature control hysteresis (P26/P27)}$, gas control signal output 220V.

Buffer water tank temperature $T10 \geq \text{heating heat source setting temperature}$, gas control signal output 0V.

(2) When $P21 < \text{ambient temperature} < P22$, the heat pump can be turned on;

Buffer water tank temperature $T10 < \text{Heating heat source joint temperature upper limit P110}$, the heat pump is allowed to turn on for heating, and it is normally controlled according to the inlet water temperature T8/outlet water temperature T15.

Buffer water tank temperature $T10 \geq \text{heating heat source joint temperature upper limit P110}$, heat pump stops heating, if buffer water tank temperature $T10 < \text{heating setting temperature}$, turn on gas control signal output 220V, continue heating to the set temperature.

Buffer water tank temperature $T10 \geq \text{heating set temperature}$, gas control signal output 0V.

When the ambient temperature is greater than or equal to P22, turn on the heat pump for heating, control normally according to the inlet and outlet water temperature T8/outlet water temperature T15, and prohibit gas heating.

B. In hot water mode, heat pump heating is prohibited, and only AHS gas heating is allowed:

Hot water tank temperature $T16 < \text{hot water setting temperature} - \text{hot water control hysteresis}$, gas control signal output 220V.

Hot water tank temperature $T16 \geq \text{hot water setting temperature}$, gas control signal output 0V.

In the hot water + floor heating, hot water + heating mode, the heating operates according to the above 1, and the hot water operates according to the above 2.

Other instructions:

(1) When the ambient temperature fails, handle it according to the ambient temperature $\leq P22$.

(2) In single (heating/floor heating) mode, there is no demand for hot water by default.

(3) During online control, the slave machine follows the buffer water tank temperature T10 of the master machine.

(4) When the gas control signal is output and the heat pump does not start, the water pump of the main engine needs to be turned off, and it will be turned on only when the antifreeze conditions are met.

(5) When the unit enters the second-level antifreeze, the gas water heater starts and the heat pump starts at the same time.

(6) The gas water heater starts when defrosting.

(7) When P26 and P27 are set to 0, the fixed hysteresis is set to 5°C.

3.1.12. Heating auxiliary electric heater EH2

Floor heating and heating mode valid parameters P139=0 enable, P139=1 invalid, P139=2 gas control

A. When the water pump is detected to stop in any state, the electric heating will stop immediately.

B. After the unit enters the antifreeze protection on the heating side, the heating auxiliary electric heater EH2 will be turned on after the water pump starts for 10 seconds.

C. When the unit is not anti-freezing, when it is turned off or turned on for cooling, the heating auxiliary electric heater EH2 stops.

D. When the unit is in the heating or floor heating mode, follow the following controls:

ARDEN Heat Pumps Pty

(1) The unit has no shutdown fault protection:

1) Start-up condition of the heating auxiliary electric heater EH2: when the following conditions are met at the same time, the heating auxiliary electric heater EH2 is started

① Outdoor ambient temperature $T7 \leq$ electric heating set ambient temperature (parameter P22, default -7), when the external ambient temperature T7 sensor fails, this item is invalid;

② Inlet water temperature $T8 <$ set temperature-return difference (parameter P26);

2) Stop condition of heating auxiliary electric heater EH2: meet any of the following conditions, stop heating auxiliary electric heater EH2

① When the outdoor ambient temperature $T7 \geq$ the set ambient temperature of electric heating + 3°C, this item is invalid when the outdoor ambient temperature T7 sensor fails;

② Inlet water temperature $T8 \geq$ set temperature.

(2) The unit has shutdown fault protection:

1) Heating auxiliary electric heating EH2 start conditions: when the following conditions are met at the same time, start electric heating.

① Inlet water temperature T8 sensor is normal.

② Inlet water temperature $T8 <$ set temperature-return difference 【P26】 .

2) Heating auxiliary electric heating EH2 stop conditions: meet any of the following conditions, stop heating auxiliary electric heating EH2.

① Inlet water temperature T8 sensor failure.

② Inlet water temperature $T8 \geq$ set temperature.

(3) When the outdoor unit is defrosting: turn on the heating auxiliary electric heater EH2 during the defrosting process, and continue to judge according to the above conditions after exiting the defrosting.

Note: When the temperature control mode of the unit is P116=0, it is controlled according to the inlet water temperature T8.

When the temperature control mode of the unit is P116=1, it is controlled according to the outlet water temperature T15.

3.1.13. Unit auxiliary pump P_c

161 Auxiliary pump selection type: 0: hot water/1: air conditioner/2: floor heating/3: air conditioner floor heating/4: all, the default is 0.

When operating in the corresponding mode, when the main engine circulation pump P_a starts, the auxiliary pump P_c of the unit starts at the same time.

3.1.14. Hot water three-way valve SV1

(1) In hot water mode: the three-way valve SV1 is normally open and energized.

(2) Non-hot water mode: the three-way valve SV1 is normally closed and energized.

3.1.15. Air conditioning three-way valve SV2

(1) In heating or cooling mode: the three-way valve SV2 is normally open and energized.

(2) Under floor heating mode: the three-way valve SV2 is normally closed and energized.

(3) Antifreeze Enter the antifreeze according to the outlet water temperature T15 or the temperature of the hot water tank T16, and open the three-way valve in the corresponding mode.

(4) According to the defrosting mode in the current mode, open the three-way valve in the corresponding mode.

3.1.16. Air conditioner secondary water pump P_b (secondary system)

A. When P150=1 is selected: the unit will start running when there is a start signal or when the unit reaches temperature and is on standby;

B. When P150=2 is selected: the air conditioner pump runs in linkage.

(1) When the terminal equipment has a heating or cooling demand, the feedback signal is turned on, and the P_b water pump is turned on;

(2) When the terminal equipment has no demand for heating or cooling, the signal of shutting down is fed back, and the P_b water pump is turned off.

C. When P150=3 is selected: control as follows, DC water pumps and AC water pumps share this logic, no signal feedback alarm.

(1) When the host is heating up:

1) When the indoor temperature is $<$ indoor set temperature -2°C , the P_b water pump starts and runs at the speed [P100];

2) Indoor temperature $<$ indoor set temperature -1°C , P_b pump speed $+2\%/40\text{sec}$, maximum output 100%;

3) Indoor temperature $>$ indoor set temperature $+2^{\circ}\text{C}$, P_b water pump is turned off;

4) Indoor set temperature $+2^{\circ}\text{C} \geq$ indoor temperature \geq indoor set temperature $+1^{\circ}\text{C}$, P_b pump speed $-2\%/40\text{sec}$, minimum output \geq 【P100】 ;

5) Indoor set temperature $-1^{\circ}\text{C} <$ indoor temperature $<$ indoor set temperature $+1^{\circ}\text{C}$, P_b pump speed remains unchanged.

(2) When the host is cooling:

1) When the indoor temperature $>$ indoor set temperature $+2^{\circ}\text{C}$, the P_b water pump starts and runs at the speed [P100].

2) Indoor temperature $>$ Indoor set temperature $+1^{\circ}\text{C}$, P_b pump speed $+2\%/40\text{sec}$, maximum output 100%.

3) When the indoor temperature is $<$ indoor set temperature -2°C , the P_b water pump is turned off.

4) Indoor set temperature $-1^{\circ}\text{C} \geq$ indoor temperature \geq indoor set temperature -2°C , P_b pump speed $-2\%/40\text{sec}$, minimum output \geq 【P100】

5) Indoor set temperature $-1^{\circ}\text{C} <$ indoor temperature $<$ indoor set temperature $+1^{\circ}\text{C}$, P_b pump speed remains unchanged.

Note: The wire controller has a built-in indoor temperature NTC sensor

D. The speed regulation of the water pump is optional. If the speed regulation of the water pump is not needed, just connect the water pump directly to the secondary pump relay.

3.1.17. Heat source hot water pump P_e

Opening conditions:

(1) When the temperature of the heat source on the hot water side T12 $>$ the temperature of the hot water tank T16 + the hysteresis of the hot water heat source P151 (the default is 7°C , when it is set to 0, the conditions (1) and (2) are shielded);

(2) When the temperature of the heat source on the hot water side T12 $<$ the set temperature of the hot water;

(3) When the heat source linkage switch DI6 is closed;

If the above conditions are met at the same time, the heat source water pump is turned on.

Closing condition:

ARDEN Heat Pumps Pty

(1) When it is detected that the temperature of the heat source on the hot water side $T_{12} \leq$ the temperature of the hot water tank T_{16} - the hysteresis of the hot water heat source P151 (**when it is set to 3, conditions (1) and (2) are shielded**),

(2) When it is detected that the temperature of the hot water tank $T_{16} \geq$ the set temperature of the heat source on the hot water side,

(3) When the heat source linkage switch DI6 on the hot water side is turned off;

If any of the above conditions is satisfied, the heat source water pump P_e on the hot water side is turned off.

Note: When the hot water side heat source linkage switch DI6 is closed, it enters the hot water side heat source joint mode (this mode is not reflected on the display screen), and the set temperature defaults to 70°C. When the linkage is disconnected, the set temperature returns to the previous set temperature of the water tank on the hot water side.

3.1.18. Heat source heating water pump P_f

Opening conditions:

(1) When it is detected that the temperature of the heat source on the heating side is $T_{11} >$ the temperature of the heating buffer water tank T_{10} + the hysteresis of the heat source P152 (when the default setting is 0 at 7°C, conditions (1) and (2) are shielded),

(2) When it is detected that the temperature of the hot water tank $T_{16} <$ heating set temperature,

(3) When the heat source linkage switch DI6 on the heating side is closed,

If the above conditions are met at the same time, the heat source water pump is turned on.

Closing condition:

(1) When it is detected that the temperature of the heat source on the heating side $T_{11} \leq$ the temperature of the heating buffer water tank T_{10} - the hysteresis of the heat source P152 (when it is set to 3, conditions (1) and (2) are shielded),

(2) When it is detected that the temperature of the heating buffer water tank $T_{10} \gg$ the heating set temperature,

(3) When the heat source linkage switch DI6 on the hot water side is turned off;

If any of the above conditions are met, the heat source water pump on the hot water side is turned off.

Note: When the heating side heat source linkage switch DI6 is closed, it enters the heating side heat source joint mode (this mode is not reflected on the display screen), and the set temperature defaults to 60°C. When the linkage is disconnected, the set temperature returns to the previous set temperature of the water tank on the heating side.

3.1.19. winter frost protection

In order to prevent the circulating water of the unit from freezing in winter, the unit adds antifreeze protection control.

3.1.19.1. Freeze Protection Entry Exit Condition

A. When the unit is in shutdown or startup fault shutdown state

(1) Entry and exit of primary antifreeze protection

1) When the outdoor ambient temperature $T_7 \leq 5^\circ\text{C}$ [P117], it enters the first-level antifreeze protection, the main engine circulating water pump P_a is turned on for 2 minutes every 10 minutes (parameter P29, default 2 minutes), and each waterway runs for 2 minutes;

2) When the outdoor ambient temperature $T_7 \geq$ [P117] +3°C, exit the first-level antifreeze protection;

(2) Entry and exit of secondary antifreeze protection

ARDEN Heat Pumps Pty

1) When the outdoor ambient temperature $T7 \leq 5^{\circ}\text{C}$ [P117] and the outlet water temperature $T15 \leq 3^{\circ}\text{C}$ [P118] continues for 10s, it enters the secondary antifreeze protection. The hot water three-way valve is closed, the heating three-way valve is opened, the main engine circulating water pump P_a is turned on, and the unit is forced to start the heating operation. When the unit has an unprotected shutdown fault, after the water pump P_a runs for 10s, the auxiliary electric heating is forced to be turned on.

2) When the outdoor ambient temperature $T7 \geq [P117] + 3^{\circ}\text{C}$ or the outlet water temperature $T15 \geq 15^{\circ}\text{C}$, the secondary antifreeze protection will be disabled.

Judging from (1) and (2) above, when the outdoor ambient temperature T7 sensor fails, ignore this temperature condition; when the outlet water temperature T15 sensor fails, replace it with the inlet water temperature T8;

B. When the hot water function is enabled, the unit is shut down or shut down due to a power failure

(1) When the outdoor ambient temperature is $T7 \leq 5^{\circ}\text{C}$ [P117] and the temperature of the hot water tank is $T16 \leq 3$ 【P118】 for 10s, it will enter the secondary antifreeze protection. The hot water three-way valve SV1 is opened, the heating three-way valve SV2 is inactive, the main engine circulating water pump P_a is turned on, and the unit is forced to start the heating operation. When the unit has an unprotected shutdown failure, after the water pump P_a runs for 10s, the hot water electric heater EH1 is forced to be turned on.

(2) When the outdoor ambient temperature $T7 \geq$ 【P117】 $+ 3^{\circ}\text{C}$ or the temperature of the hot water tank $T16 \geq$ P118】 $+ 12^{\circ}\text{C}$, the secondary antifreeze protection will be disabled.

3.1.19.2. Terminal display during antifreeze

After the unit enters antifreeze protection, the wire controller displays "Antifreeze" or the icon of "water pump P_a" is on/flashing, which is not a unit failure.

3.1.19.3. Antifreeze for hot water pipes

When P48=1 and hot water function is enabled and P162 hot water pipeline antifreeze time interval is not set to 0, enter the hot water pipeline antifreeze.

When the outdoor ambient temperature $T7 \leq 2^{\circ}\text{C}$ and the interval time $> P162$, enter the hot water pipeline to prevent freezing.

When the outdoor ambient temperature $T7 \geq 4^{\circ}\text{C}$, exit the hot water pipeline to prevent freezing.

Enter the hot water antifreeze, the hot water three-way valve SV1 turns on the water pump P_a to cycle for 2 minutes and then returns to normal control, if there is a demand for hot water heating at this time, it will run the hot water mode.

When the antifreeze of the hot water pipeline is not required, it is necessary to disable the parameter P62=0 or P48=0.

3.1.20. Host water flow switch protection

A. When P101=0, that is, when the AC water pump is selected, it is detected in the following way:

(1) After the main engine water pump P_a starts running for 40 seconds, if the water flow switch is disconnected for 5 consecutive seconds, it will enter the water flow switch protection, the compressor and water pump will stop running immediately, and the fault code "E03" will be displayed on the remote control screen.

(2) When the water pump P_a detects that the water flow switch is in the closed state continuously for 10 seconds before starting, and judges that the water flow switch is in the failure state, it will enter the water flow switch protection and report E03 fault; when the water flow switch failure detection P44 is disabled, the water pump P_a will not perform failure detection before starting.

ARDEN Heat Pumps Pty

(3) After the water pump P_a stops for 1 minute, turn off the water flow switch for protection and restart the P_a water pump.

(4) If this protection occurs 3 times in a row within 60 minutes, the protection cannot be restored and must be turned off or turned off and on again or the water flow switch closed to eliminate it.

B. When P101=1, that is, when the DC variable frequency water pump is selected, the water flow switch is not detected in the heating and floor heating modes in the following way:

(1) Before starting the compressor:

The circulating water pump P_a runs at 100% output capacity for 30 seconds and then detects the water flow switch and water flow. If the water flow switch is disconnected or the water flow is less than or equal to the low water flow protection value of P134, the water pump stops running; after 5 seconds, restart the P_a water pump to enter the second cycle. Water flow switch and water flow detection; If the water flow switch is detected three times in a row or the water flow rate is \leq P134, a water flow fault will be reported and "E03" will be displayed, and the P_a pump will not be restarted after locking the fault.

During the above water flow switch and water flow detection process, if the water flow switch is closed and the feedback water flow is greater than the P134 low water flow protection value, it is judged that the water flow of the unit is normal and enters the start-up process. The fan and compressor start successively and resume normal operation.

(2) After the compressor starts:

If the water flow switch is disconnected for 5 seconds or the water flow \leq P134 low water flow protection value lasts for 5 seconds, a water flow failure will be reported, the unit will stop, and the fault code E03 will be displayed. After the water pump stops for 30 seconds, it will enter the water flow detection before the compressor starts.

Note 1: After the water flow fault is locked, as long as the unit is powered on again or turned off and on again or detects that the water flow switch is closed or the water flow is \geq P134 water flow low protection value, the water flow fault will be automatically released and normal operation will resume.

Note 2: When P03=1, the water flow switch is not detected; when P134=0, the water flow is too low.

Note 3: If the unit meets the anti-freezing conditions, it will enter the anti-freezing control first, and at this time, the detection of the water flow switch will be shielded.

Note 4: When P03=0, when the water flow switch is enabled:

1) In the hot water, floor heating, and heating modes, the water flow switch protection during the operation of the unit is shielded, but the water flow switch detection before the compressor starts is still valid;

2) In the cooling and defrosting modes, the water flow limit frequency protection and water flow switch protection are both effective.

When P03=1, the water flow switch protection including water flow switch failure detection is completely shielded.

3.1.21. Protection against excessive temperature difference between inlet and outlet pipes

(1) After the compressor starts running for 3 minutes, it is detected that the outlet water temperature T15-inlet water temperature T8 \geq temperature difference protection value (parameter P23) or the inlet water temperature T8-outlet water temperature T15 \geq temperature difference protection value (parameter P23) in non-hot water mode for 10 seconds, that is, the temperature difference between the inlet and outlet water is too large to protect. The unit stops immediately, and the fault code "E37" is displayed on the remote control screen.

(2) After the unit is shut down for protection for 3 minutes, exit the protection for excessive temperature difference between the inlet and outlet water pipes.

3.1.22. High voltage protection

(1) In refrigeration mode, after the compressor starts running, if the high pressure saturation temperature is $\geq 64^{\circ}\text{C}$ (parameter P11) for 5 seconds, the compressor will stop immediately and the fault code "E51/E53" will be displayed on the screen of the remote controller.

(2) One minute after the unit is shut down for protection, when the high pressure saturation temperature is $\leq 50^{\circ}\text{C}$, the protection will exit. If this protection occurs 3 times in a row within 60 minutes, the protection cannot be restored and must be removed by powering off.

3.1.23. Low voltage protection

(1) In heating mode, after the compressor starts running for 5 minutes, if the low pressure and high pressure saturation temperature is $\leq -40^{\circ}\text{C}$ (parameter P13) for 5 consecutive seconds, the compressor will stop running immediately, and the fault code "E52/ E54";

(2) Any of the following situations shields the low voltage protection detection:

The outdoor unit is in the process of defrosting and within 3 minutes after exiting defrosting;

During recovery of refrigerant;

Ambient temperature ≤ -10 and the compressor starts for 3 minutes.

(3) After the unit is shut down for protection for 1 minute, when the low pressure and high pressure saturation temperature is $\geq -35^{\circ}\text{C}$, the protection will be exited;

(4) If this protection occurs continuously for 3 times within 60 minutes, the protection cannot be restored, and the power must be cut off to clear it.

3.1.24. Exhaust temperature too high protection

(1) After the compressor starts running, if the compressor discharge temperature $T_3 \geq 115^{\circ}\text{C}$ (parameter P15) for 5 consecutive seconds, the compressor will stop running immediately; and the fault code "E12/E13" will be displayed on the screen of the remote controller.

(2) One minute after the unit is shut down for protection, when the compressor discharge temperature $T_3 \leq 90^{\circ}\text{C}$, the discharge temperature protection will be exited.

(3) If this protection occurs 3 times in a row within 60 minutes, the protection cannot be restored, and the power must be turned off to remove it.

3.2. Display and operation of the wire controller

3.2.1. Wire controller interface display and operation

A. Schematic diagram of the operation panel

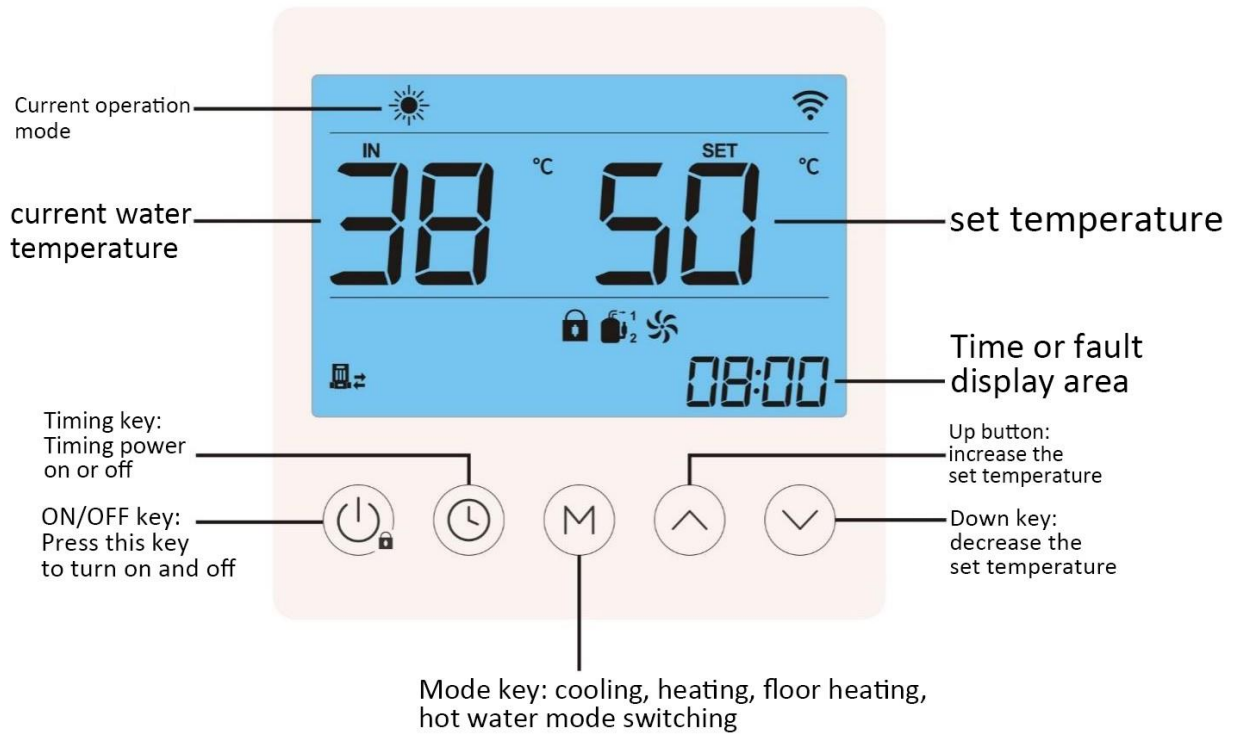

(1) switch machine

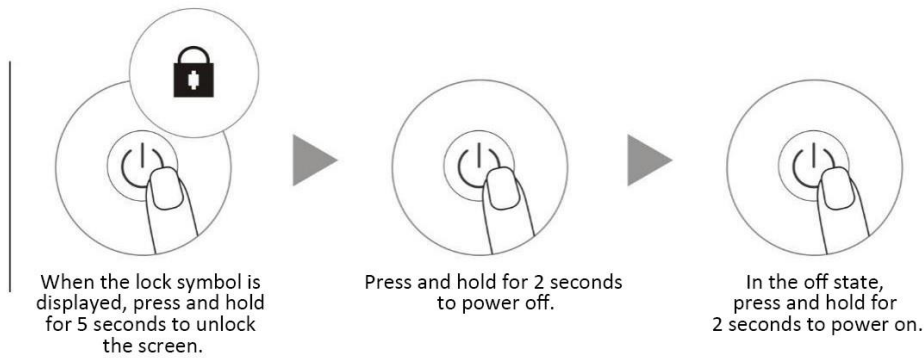

(2) mode

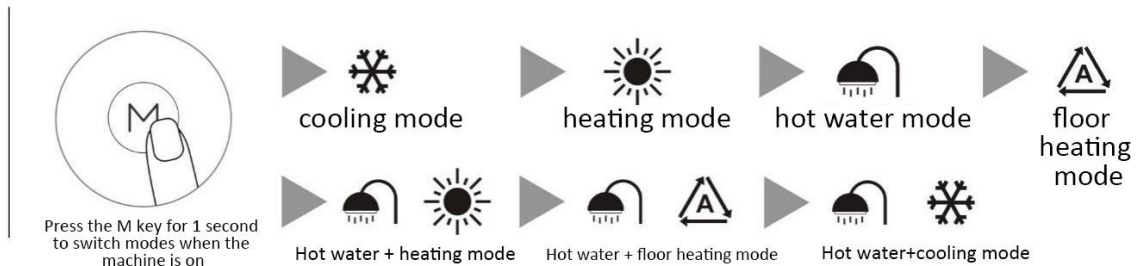

(3) Temperature regulation

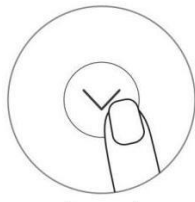

Press the up button to increase the set temperature

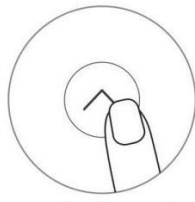

Press the key to lower the set temperature

If there is no operation for 5 seconds or press the switch key, it will automatically save the set temperature and return to the main interface.

(4) Time setting

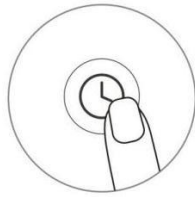

Press the clock button for 1 second to enter the current time setting



Press the clock button again, the hour display area flashes

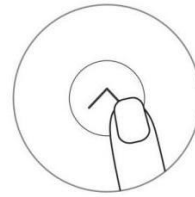

Up and down keys to adjust the value

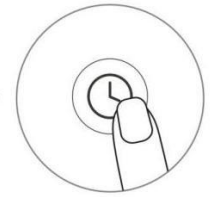

Press the clock button again to enter the minute time setting



Press the clock button again and the minute display area will flash

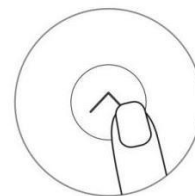

Up and down keys to adjust the value

If there is no operation for 5 seconds or press the switch key, it will automatically save the set temperature and return to the main interface.

(5) Start the machine regularly on the day

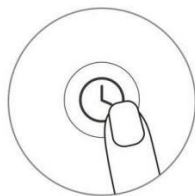

Press and hold the clock button for 5 seconds to enter the timing power-on time setting



Press the clock button again, the hour display area flashes

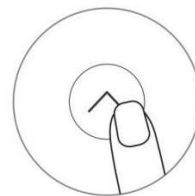

Up and down keys to adjust the value

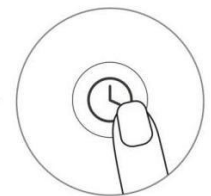

Press the clock button again to switch the minute time setting



Press the clock button again and the minute display area will flash

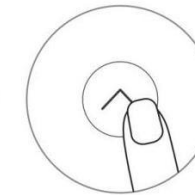

Up and down keys to adjust the value

If there is no operation for 5 seconds or press the switch button, it will automatically save the set temperature and return to the main interface, and 3 timings can be set every day.

Long press the clock button again for 5 seconds to cancel the timing

(6) Enable and disable weekly timing

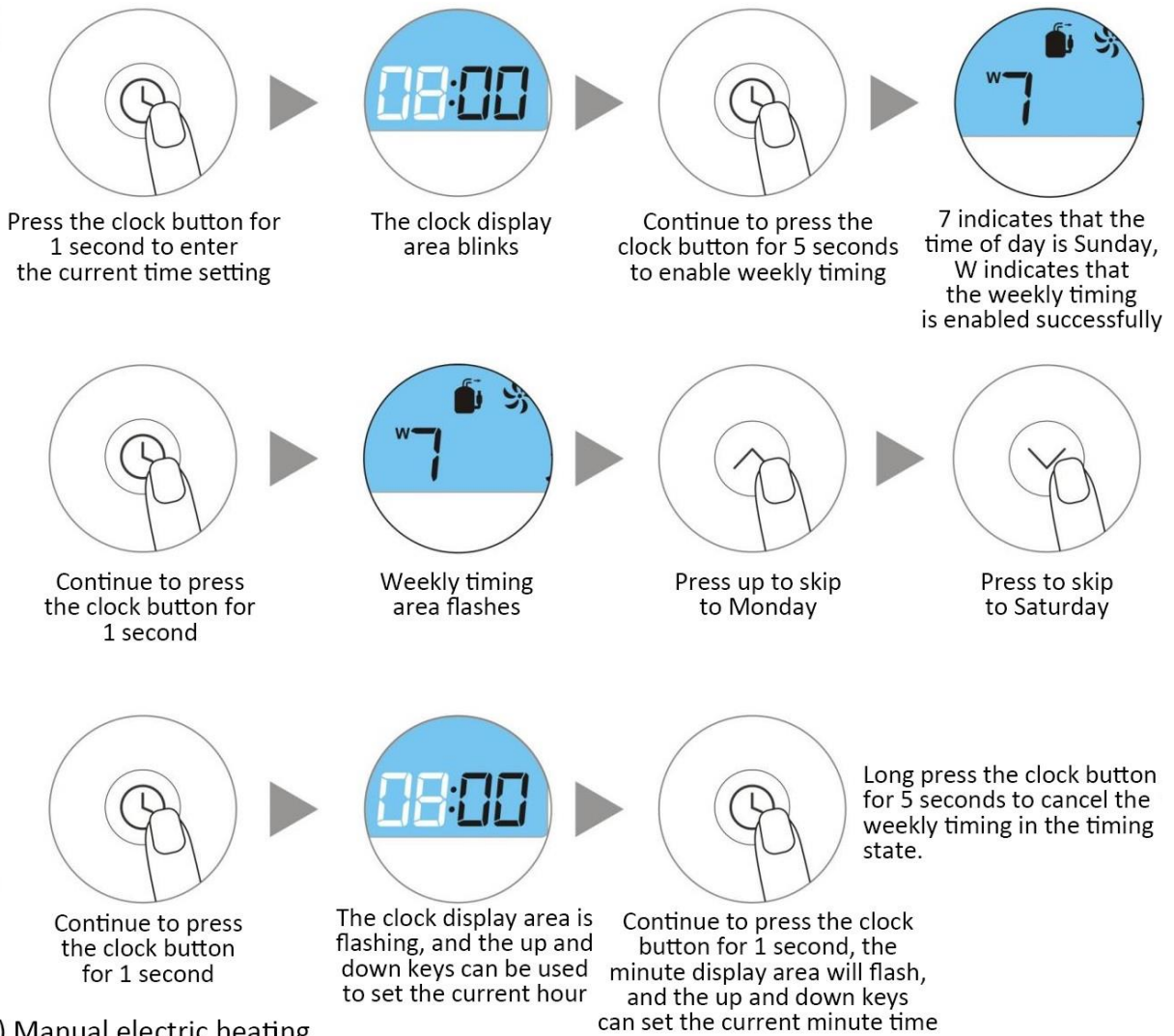

(7) Manual electric heating

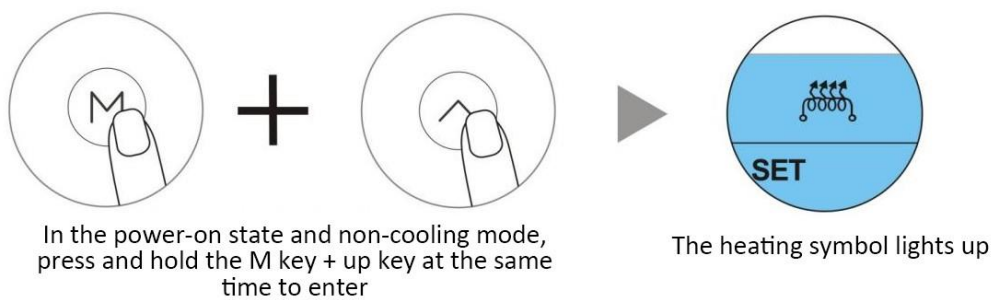

(8) Manual defrosting

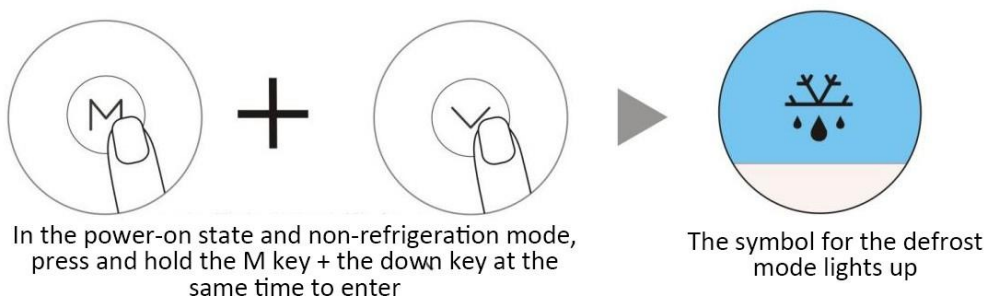

(9) ECO mode

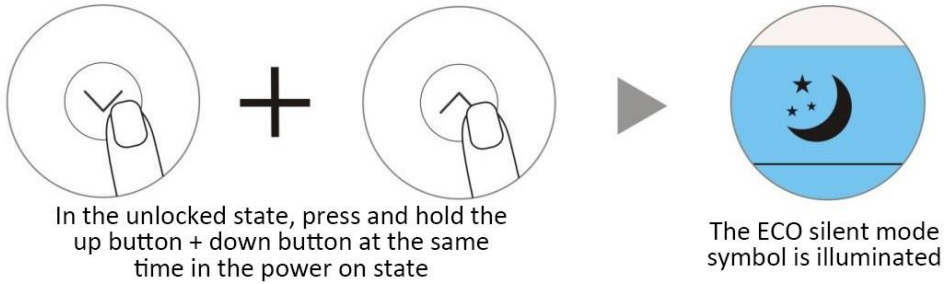

(10) Water pump forced emptying mode

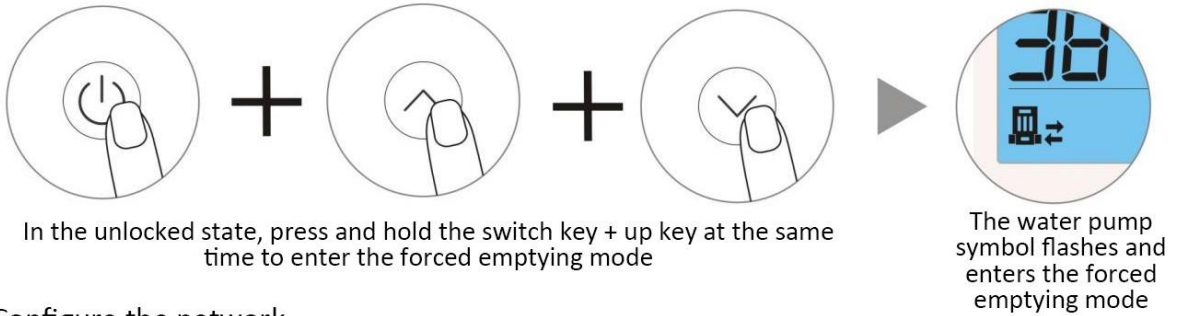

(11) Configure the network
Manual intelligent network distribution

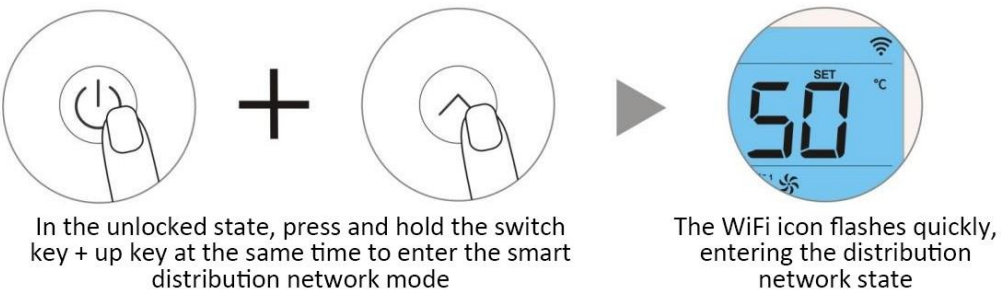

Manual AP configuration

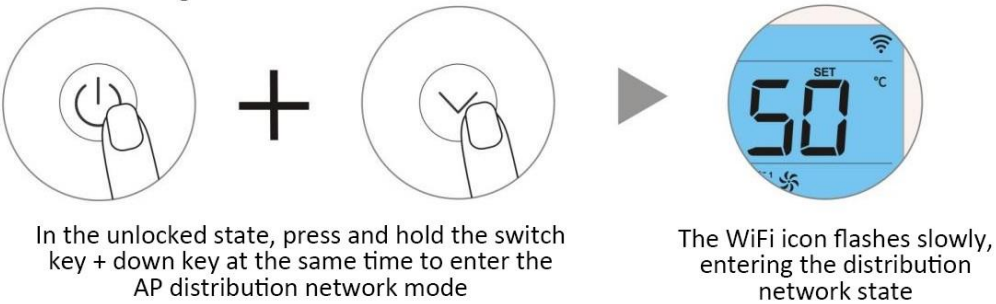

(12) APP entrance



Scan the QR code to download the "Tuya Smart" APP



Scan the QR code to download the "Smart Life" APP

3.2.2. Setting and operation of climate temperature curve

Enable climate temperature curve

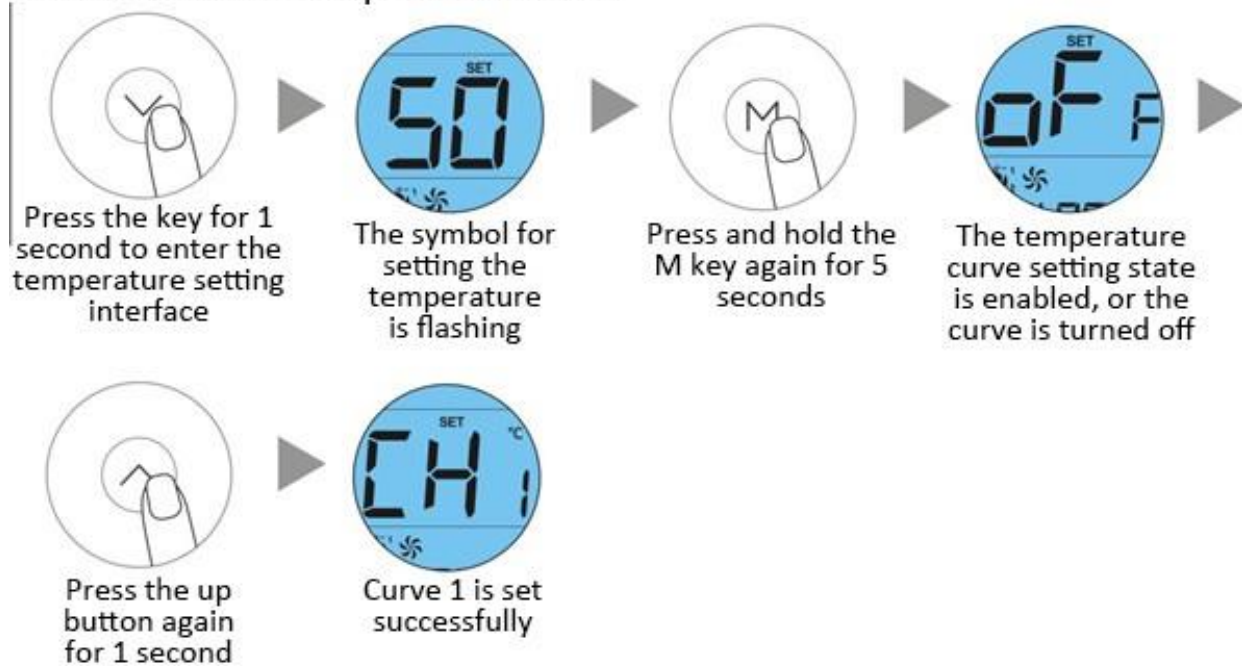

When the climate temperature curve function is enabled, the user can select one of the eight curves in the main interface, and the set temperature (T_{1s}) is determined by the outdoor temperature (T_4).

The relationship between the outdoor ambient temperature (T_4) and the set temperature (T_{1s}) is shown in the figure below:

- (1) The target setting temperature will be automatically adjusted according to the corresponding setting curve.
- (2) In the figure 4 below, curve 4 is the default curve, and curve 6 is the ECO energy-saving curve.

Heating high water temperature climate temperature compensation curve HH1-HH8

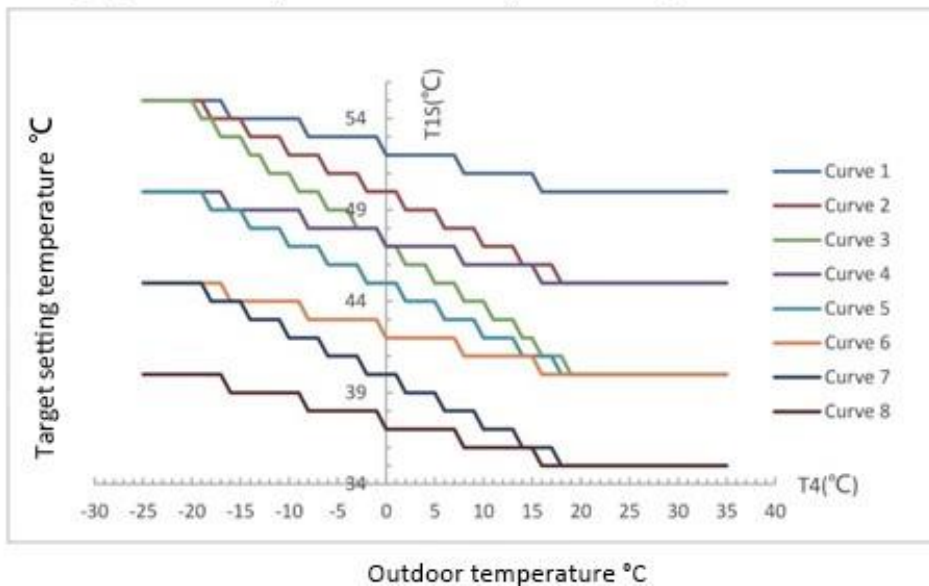

ARDEN Heat Pumps Pty

Heating low water temperature climate temperature compensation curve CH1-CH8

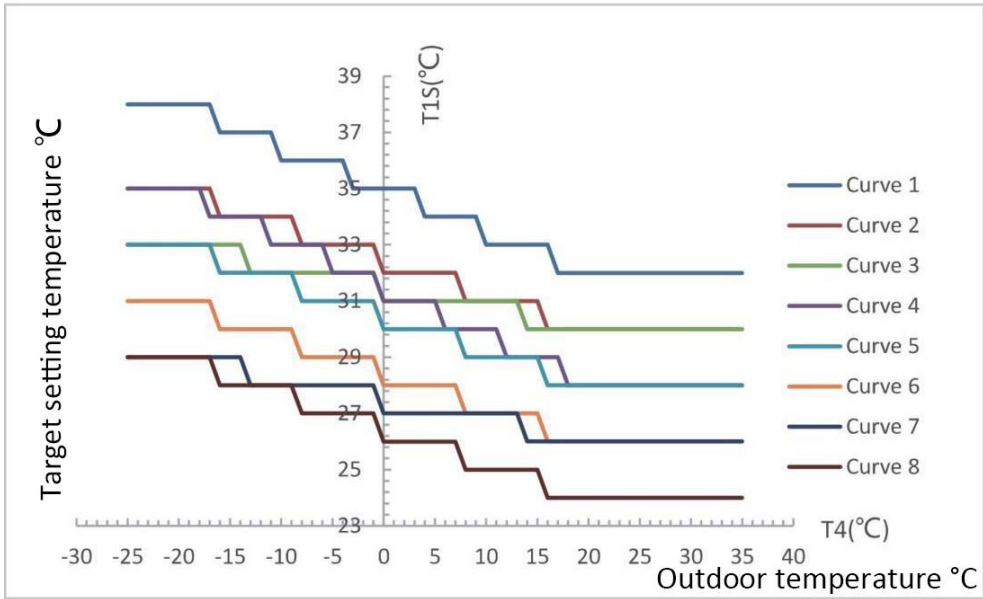

Cooling High Water Temperature Climate Temperature Compensation Curve CH1-CH8

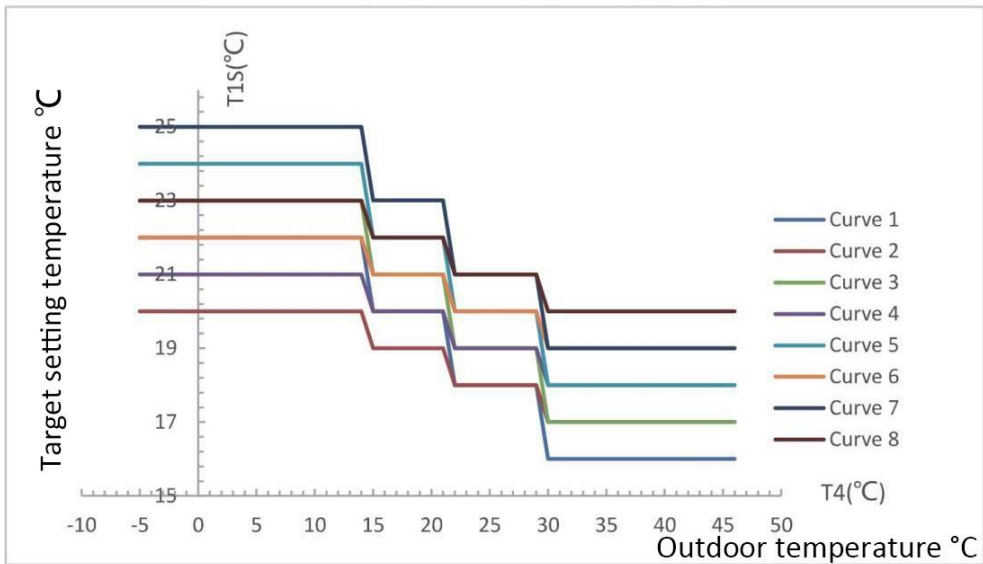

Cooling low water temperature climate temperature compensation curve CL1-CL8

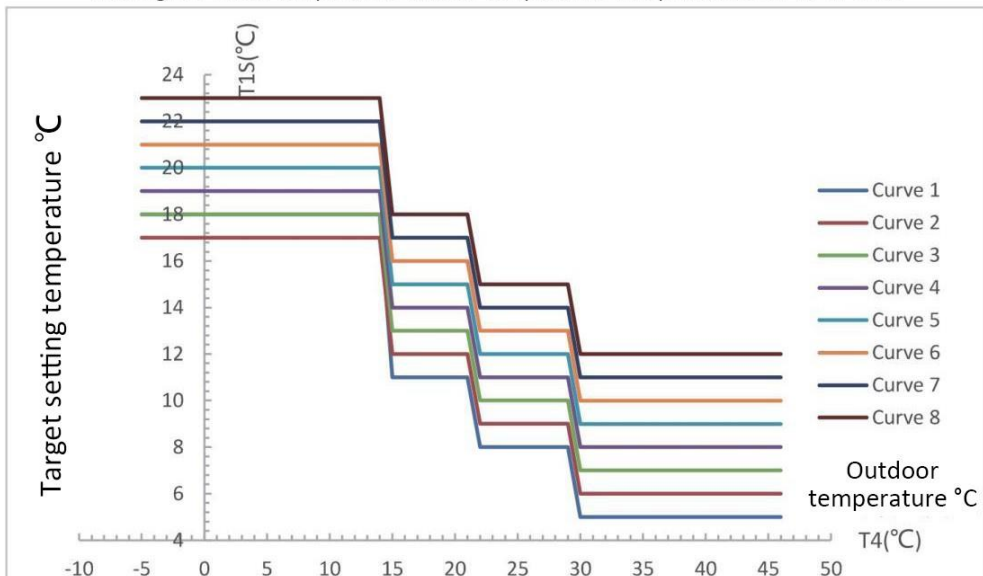

3.2.3. Setting and operation of unit tooling number

The model tooling number correspondence table is as follows:

Model tooling number comparison table			
Model	BLN-006TC1	BLN-012TC1/3	BLN-018TC1/3
tooling number	115	116	117

Table3-1

Each model has a unique tooling number, which determines the factory default parameters of the modified model. If the tooling number is set incorrectly, the heat pump unit will not operate normally. Therefore, when the main control board PCB (AP1) needs to be replaced during the maintenance of the equipment, it is necessary to set the correct tooling number to allow the machine to start.

The specific operation method is as follows:

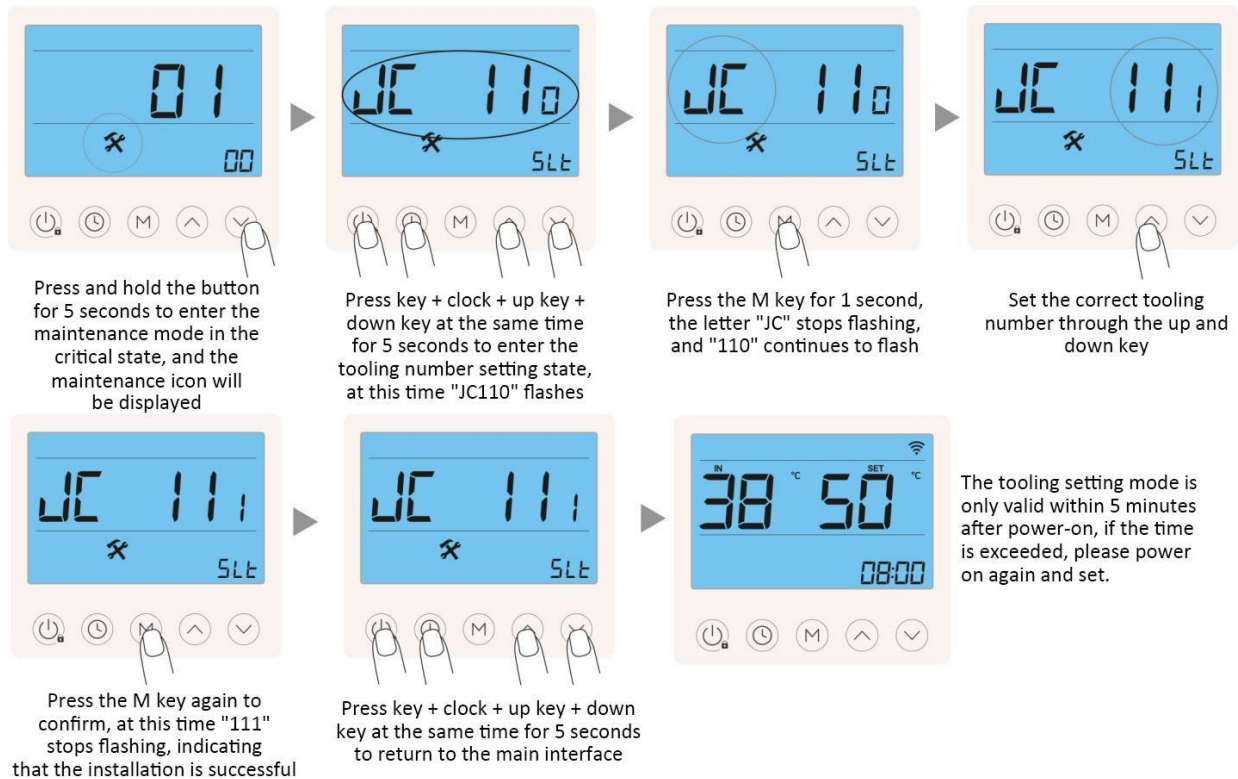

3.2.4. Network connection method and display of multiple units

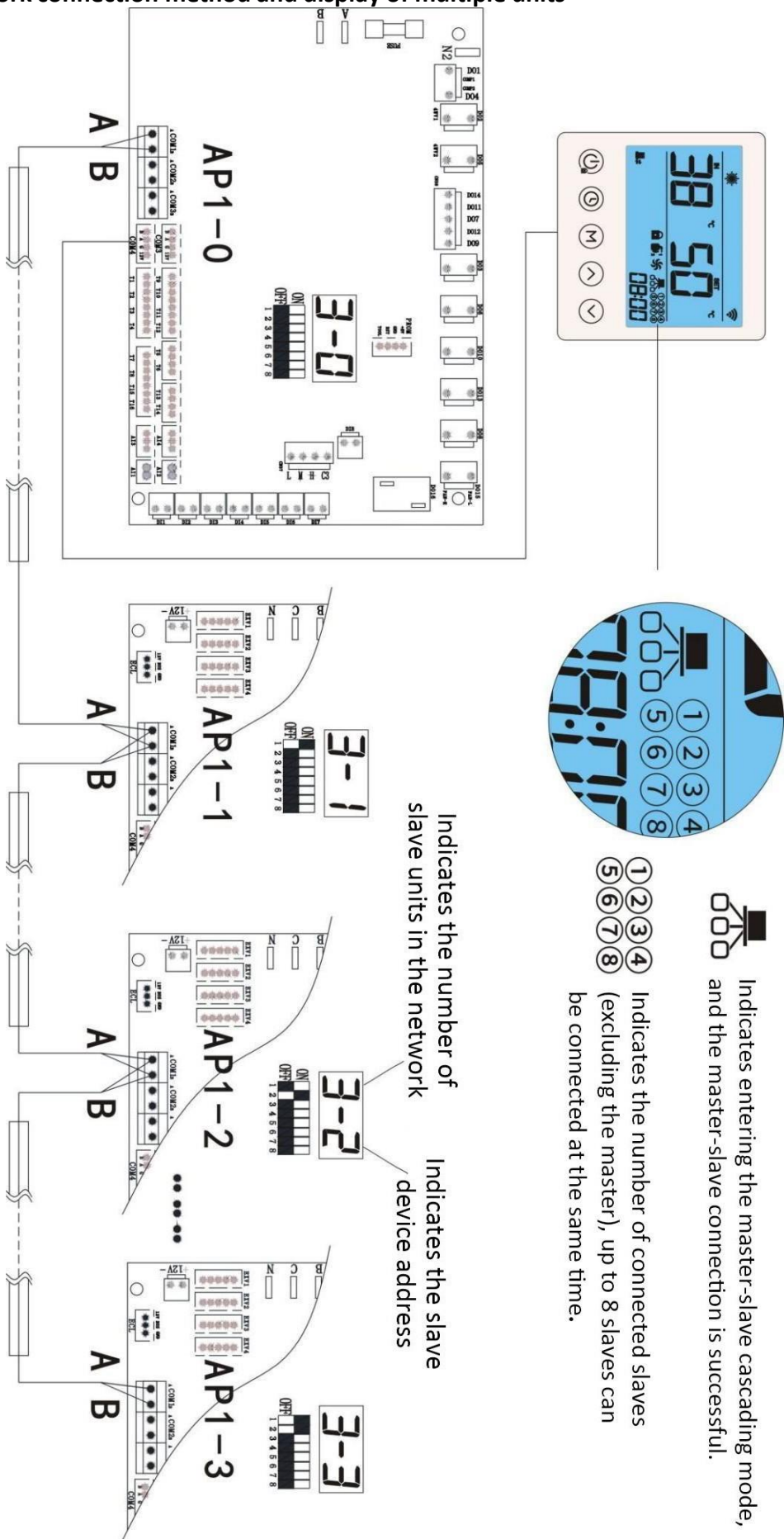

When using modular control, please be sure to check the device address before powering on the unit. The

ARDEN Heat Pumps Pty

master group number is "0", the 1# slave address is "1", the 2# slave address is "2", and so on. Please refer to the table below:

NO.	SE1	SE2	SE3	SE4	Description	Note
1	OFF	OFF	OFF	OFF	the host	
2	ON	OFF	OFF	OFF	Slave 1	
3	OFF	ON	OFF	OFF	Slave 2	
4	ON	ON	OFF	OFF	Slave 3	
5	OFF	OFF	ON	OFF	Slave 4	
6	ON	OFF	ON	OFF	Slave 5	
7	OFF	ON	ON	OFF	Slave 6	
8	ON	ON	ON	OFF	Slave 7	
9	OFF	OFF	OFF	ON	Slave 8	

Table3-2

3.2.5. Operation method of unit status parameter query

Stand-alone status query

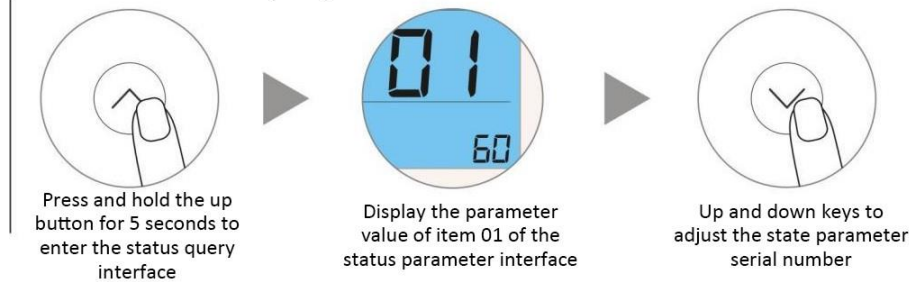

Master-slave mode status query

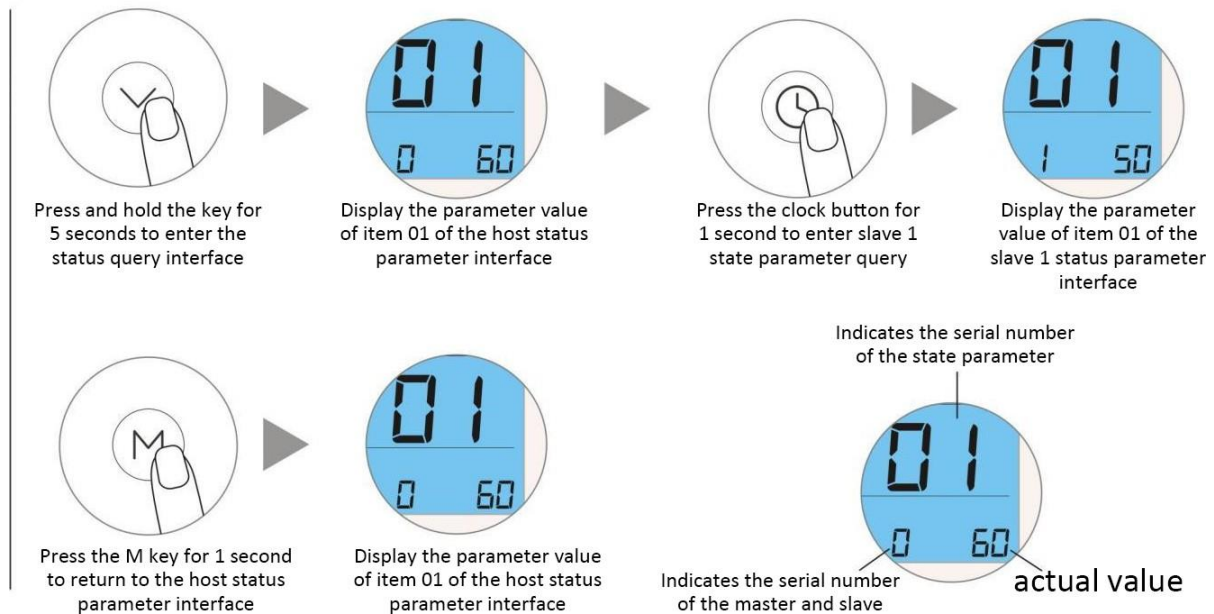

State parameter table

code	representative meaning	display range	code	representative meaning	display range
1	Compressor operating frequency	0~150Hz	31	reserve	
2	Fan operating frequency/speed	0~999Hz	32	reserve	
3	Electronic expansion valve steps	0~480P	33	reserve	
4	EVI valve steps	0~480P	34	reserve	
5	AC input voltage	0~500V	35	reserve	

ARDEN Heat Pumps Pty

6	AC input current	0~50.0A	36	reserve	
7	compressor phase current	0~50.0A	37	reserve	
8	Compressor IPM temperature	-40~140℃	38	reserve	
9	High pressure saturation temperature AI4	-50~200℃	39	reserve	
10	Low pressure saturation temperature AI3	-50~200℃	40	reserve	
11	External ambient temperature T7	-40~140℃	41	reserve	
12	Outer coil (fin) T1	-40~140℃	42	reserve	
13	Inner coil (plate replacement) T4	-40~140℃	43	reserve	
14	Return air temperature T2	-40~140℃	44	reserve	
15	Exhaust temperature T3	0~150℃	45	reserve	
16	Inlet water temperature T8	-40~140℃	46	reserve	
17	Outlet water temperature T15	-40~140℃	47	reserve	
18	Economizer inlet pipe T5	-40~140℃	48	reserve	
19	Economizer inlet pipe T6	-40~140℃	49	reserve	
20	Unit tooling number	0~300	50	reserve	
21	Water tank temperature T16	-40~140℃	51	Hot water heat source temperature T12	-40~140℃
22	Fluorine outlet antifreeze temperature T14	-40~140℃	52	Heating heat source temperature T11	-40~140℃
23	Driver manufacturer	0~10	53	Heating buffer water tank temperature T10	-40~140℃
24	Water pump speed PWM	0~100%	54	Total outlet water temperature T9	-40~140℃
25	water flow	3~100L/min			
26	User return water temperature T13	-40~140℃			
27	reserve				
28	reserve				
29	reserve				
30	reserve				

Table3-3

3.2.6. Factory parameter setting method

3.2.6.1. Single unit parameter setting

Factory parameter setting

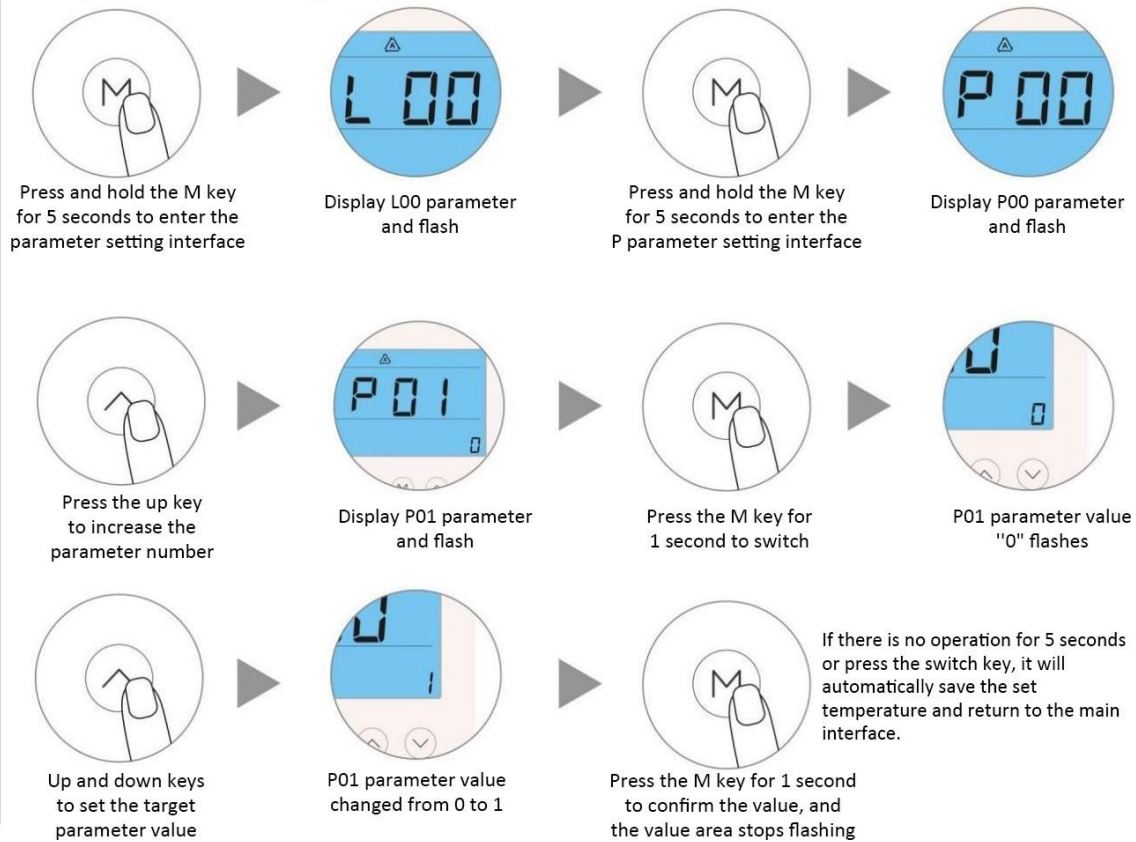

3.2.6.2. Parameter settings in master-slave cascade mode

In the state of setting parameters, switch the master and slave through the clock key and M key:
Cascade factory parameter setting

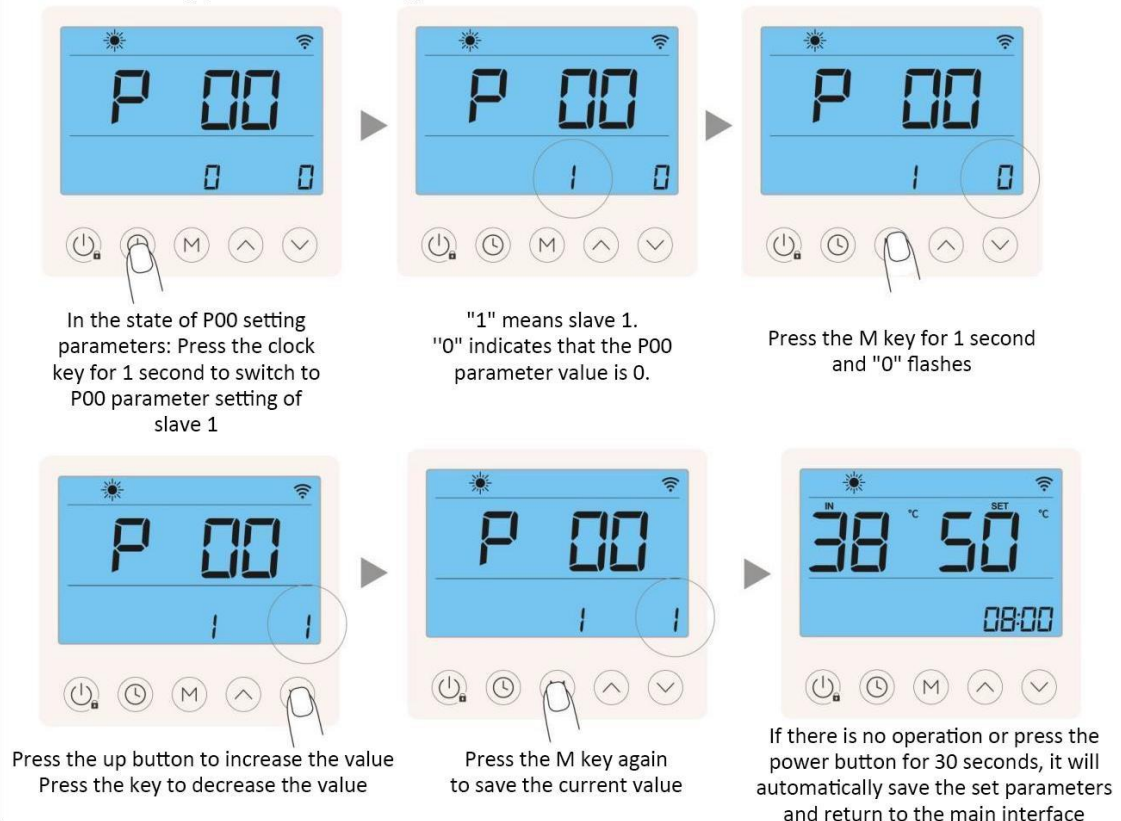

3.2.6.3. When the air conditioner secondary water pump P_b temperature control P150=3, the temperature setting operation

Press the button for 1 second in the power-on state to enter the temperature setting state

At this time, the "50" temperature display area flashes

Press the clock button for 1 second to switch to the start-stop temperature setting state of the air-conditioning water pump
· the left side displays the indoor temperature
· the right side displays the set temperature

At this time, the setting temperature area is flashing, press the key to lower the setting temperature

Press the up button for 1 second to increase the set temperature

If there is no operation for 30 seconds or press the switch key, it will save the set temperature and return to the main interface

For more detailed control functions, please refer to [3.1.16 Air Conditioning Secondary Water Pump P_b].

3.2.6.4. Enable and disable settings for hot water mode, high temperature sterilization, and antifreeze for hot water pipelines

(1) Enable and disable setting of hot water mode (P48):

In the state of setting parameters in P48: press the M key for 1 second, "0" flashes

At this time, press the up button for 1 second, and the parameter value will be changed from "0" to "1"

Press the M key for 1 second to save the data, "1" stops flashing, and the data is set successfully

When P48 is set to 0, the hot water mode is enabled (factory default enabled), the main interface has 7 modes to choose from (hot water, heating, cooling, hot water+heating, hot water+cooling, hot water+floor heating).

When P48 is set to 1, there are 3 modes to choose from on the main interface (heating, floor heating, cooling).

(2) Enabling and disabling of high temperature sterilization function (L12):

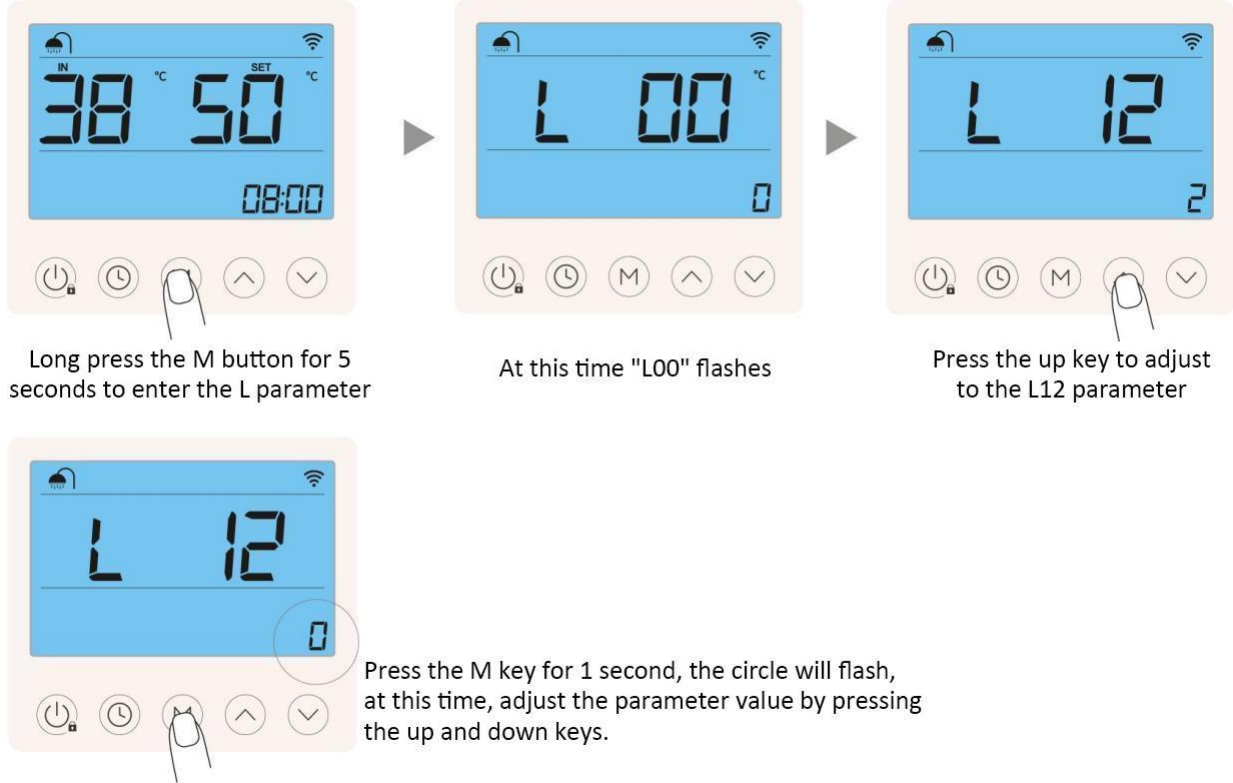

Sterilization function selection: 【L12】=0, automatic; 【L12】=1, disabled; 【L12】=2, manual. For more detailed control functions, please refer to 【3.1.4 High Temperature Sterilization】.

(3) Manually start the high-temperature sterilization function forcibly (when P140=0 and L12≠1)

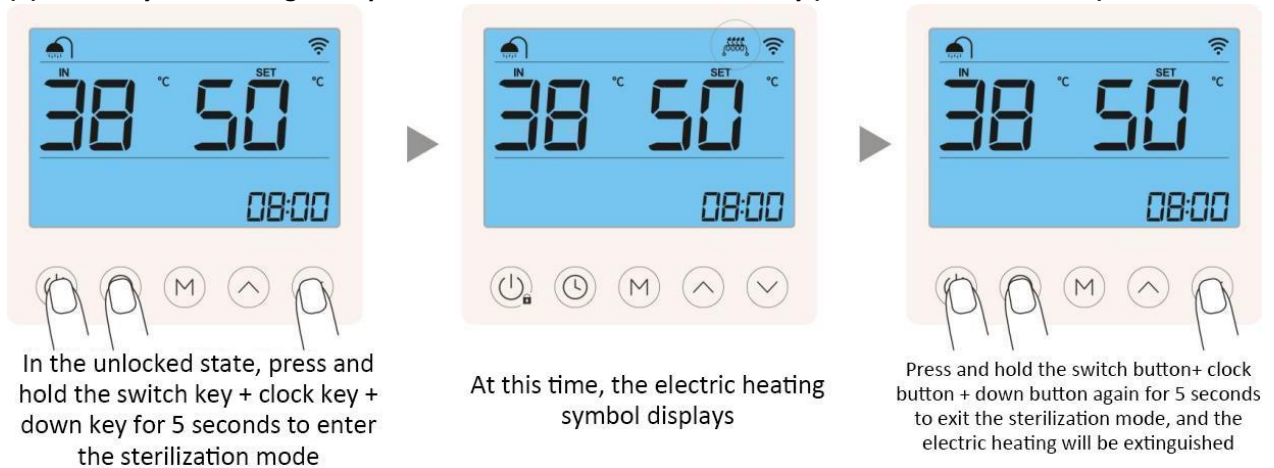

3.2.7. Reset

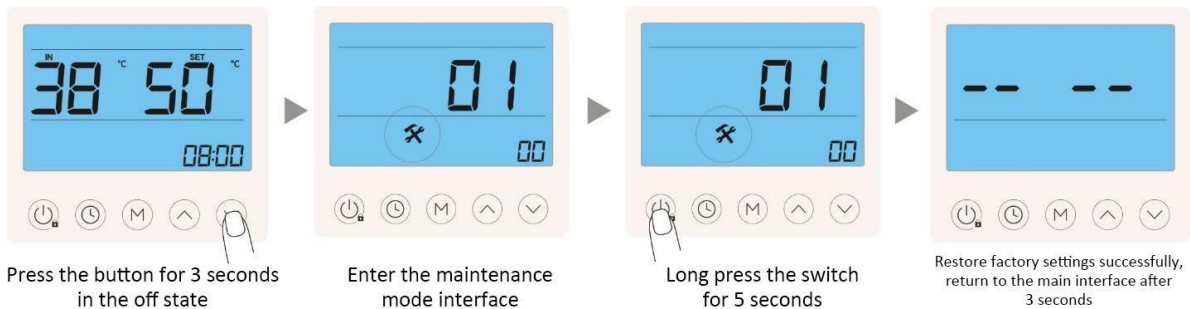

3.2.8. *Touch screen controller operation

3.2.8.1. Wired controller LCD display

(1) Power-on display

As shown in the figure below, select the corresponding language option and click "✓" to enter the system. If you do not select a language for more than 2 minutes, you will automatically enter the system according to the currently selected language, and the screen will be closed.



After entering the system, the following page is displayed. After 3 seconds, the communication is normal and the normal page will be displayed. If the communication fails, it will remain displayed. The touch will be accompanied by the sound of the button, and the screen will be turned off automatically if there is no touch operation for 2 minutes after the screen is on, and it can be woken up by clicking the screen.

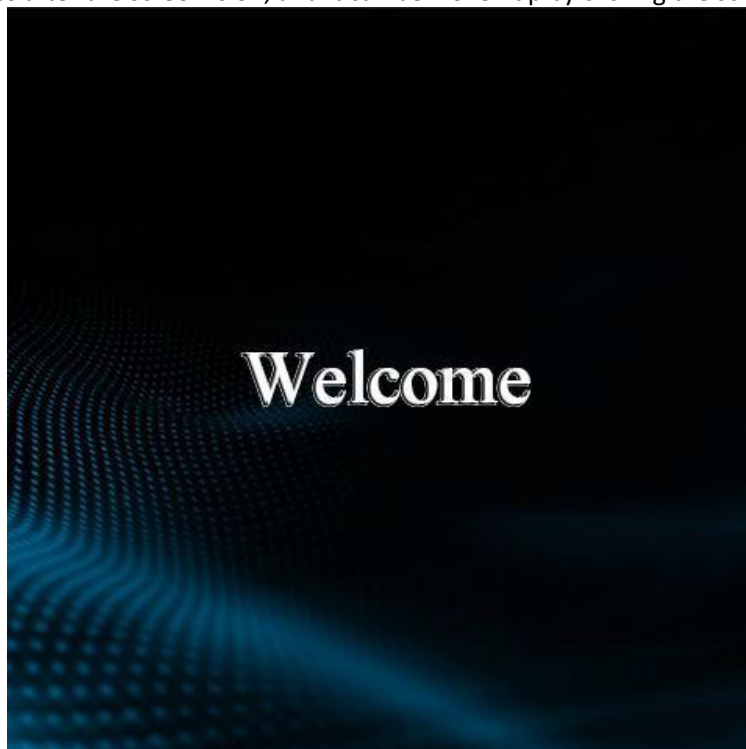

(2) main interface display



(3) Icon Description

The top of the main interface displays from left to right: time, day-month-year, week, defrost, cascade, mute, water pump, return valve, electric heating, compressor, fan, WIFI.



Defrost display: When the unit enters defrost, "❄️" is always on; when the refrigerant recovery is running, it is blinking.

Cascading display: When the unit is running in a network, "🏠" is always on.

Silent mode display: When the unit enters the silent mode, "🌙" is always on.

Timing display: When the timing function is enabled, "🕒" is always on.

Water pump display: When the water pump is running, "🚰" is always on.

Return water display: When the return water valve is activated, "🚰" is always on; when the return water valve is not activated and the return water timing is set, it will blink.

Electric heating display: When the electric heating is started, "🔥" is always on; when the electric heating is not started and the fast heating function is turned on, it will be displayed blinking at 1Hz; when the electric heating is not started and the sterilization function is turned on, it will be displayed blinking at 0.5Hz.

Compressor display: When the compressor starts, "🏠" is always on.

Fan display: When the fan starts, "🌀" is always on.







WIFI display: When the machine is connected to WIFI successfully, "📶" is always on.

Fault display: When there is a unit fault, " "  flashes, click this icon to enter the real-time fault/fault record. When the fault is eliminated, the icon will go out; click the icon to enter the fault query page; up to 20 real-time faults and 50 historical faults can be displayed.



Mode/shutdown display: In the power-on state, the current operating mode is displayed on the upper left of the main interface. The operating mode is not displayed when the machine is turned off



	floor heating
	hot water
	Heating
	Refrigeration
	hot water + heating
	hot water + floor heating
	hot water + cooling

ARDEN Heat Pumps Pty

(4) Temperature setting

A. Single mode (heating, cooling, floor heating, hot water)

- ① Click "+" "-" to adjust the set temperature of the current mode.
- ② Sliding the slider bar can also set the setting temperature of the current mode.
- ③ Click the set temperature value, enter the set temperature on the pop-up keyboard and press "Enter" to confirm the modification.



B. In combined mode (hot water + cooling, hot water + heating, hot water + floor heating)

Click to set the temperature value, enter the set temperature on the pop-up keyboard and press "Enter" to confirm the modification.



3.2.8.2. Remote control operation

(1) Power button

In the bright screen state, click the power button "  " to realize the power on/off operation.

When starting up, ON is displayed below the icon, and the current mode is displayed in the upper left corner.

When the power is off, OFF is displayed and the mode icon is off.



(2) Mode menu

When the screen is on, press the "  " key to enter the unit mode selection function page.

Click the corresponding mode on the mode selection page to realize the mode switching operation.

Press "Mode" in the upper left corner to return or "Main" in the upper right corner to return to the home page.



3.2.8.3. Function menu

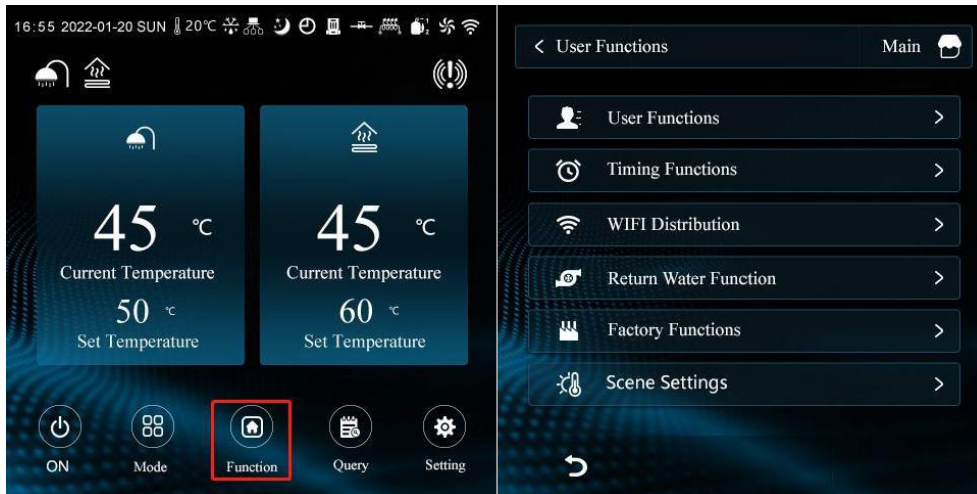

(1) User command operation

When the main interface is on, click the "Function" button to enter the function selection page.

Then click "User Functions" to enter the user command operation.

From top to bottom, they are silent mode, high temperature sterilization, forced defrosting, manual quick heating, and system emptying.

Click the corresponding button to enable/disable the corresponding function.

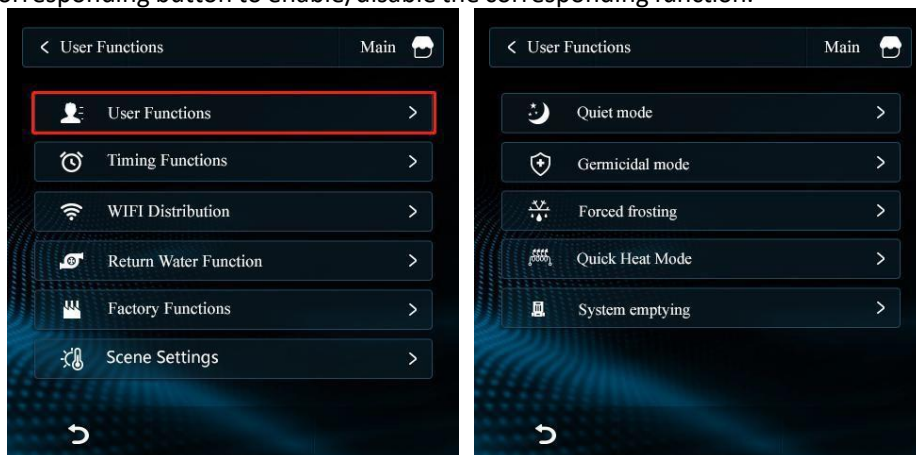

(2) Switch timing control

When the screen is on, click the "Function" button to enter the function selection page.

Then click "Timing Functions" to enter the switch timing viewing page. If you need to enable the weekly timing, click any button from Monday to Sunday to start the weekly timing. Click the time period to enter the time setting of the time period, enter the time through the keyboard, and click the enable button " " to start/close the time period. After the setting is completed, press "Enter" to save.

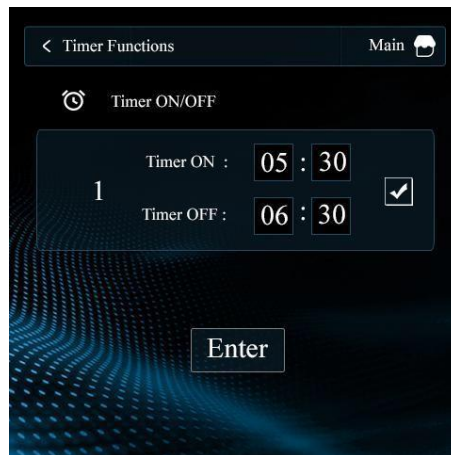
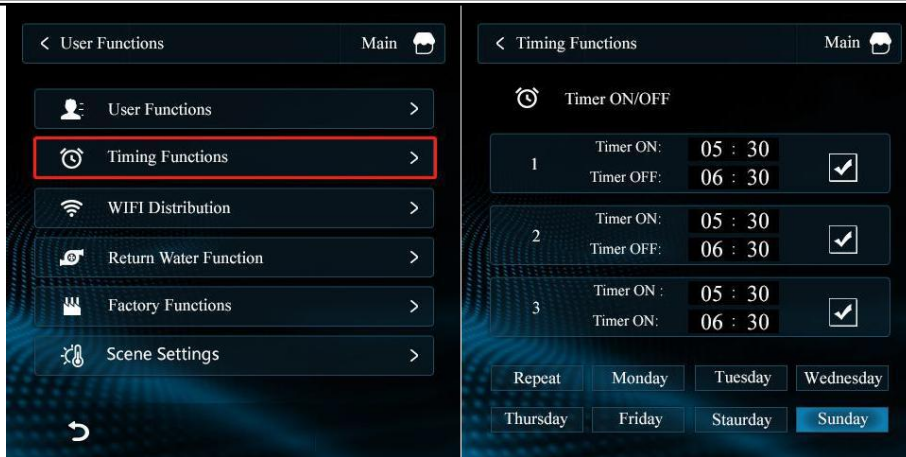

(3) WiFi distribution network

In the bright screen state, click the "🏠" button to enter the function selection page.

Click "📶 WiFi Distribution" to enter the WIFI operation interface.

Long press the button for more than 3S and release it to enter the corresponding WiFi distribution network mode, and the corresponding button lights up. (The WIFI network distribution time is 3 minutes, and exit the distribution network mode after timeout.)



(4) Timed return water temperature setting

When the screen is on, click the "🏠" button to enter the function selection page.

Then click "🔁 Return Water Function" to enter the backwater timing viewing page, the setting method is similar to that of switching on and off.

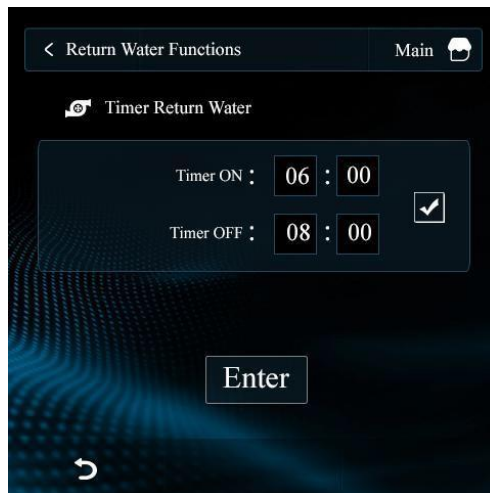
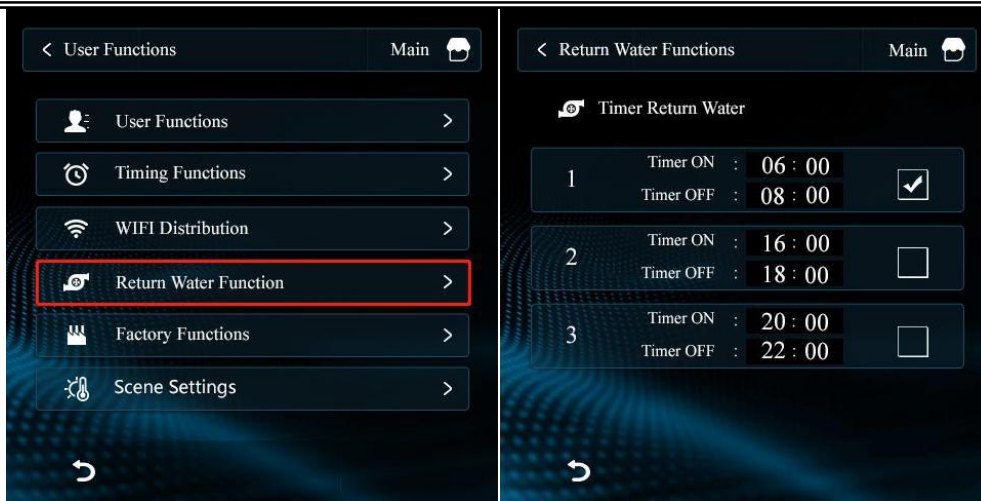

(5) Factory function

Inverter experiment test: In the bright screen state, click the "  " button to enter the function selection page.

Then click "  Factory Functions > ".

Input "1122" on the pop-up keyboard and press "Enter" to enter the factory function.

Click "  Inverter Test > " to enter the factory test interface, where you can manually control the running status of the compressor, fan, EEV, EVI and enter the IPLV test mode.



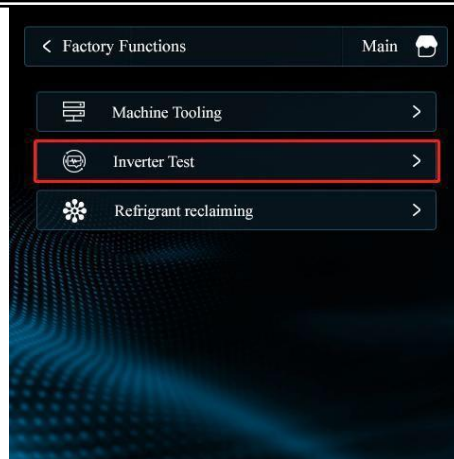

(6) Refrigerant recovery

In the bright screen state, click the "Function" button to enter the function selection page.

Then click "Funkcje fabryczne".

Enter "1122" on the pop-up keyboard, press "Enter" to enter the factory function

Long press "Refrigerant reclaiming" for more than 3 seconds and release to enter refrigerant recovery.





(7) Scene setting

In the bright screen state, click the "🏠" button to enter the function selection page.

Click "🔧 Scene Settings >" to enter the scene setting interface.

A total of 6 scene settings per day can be set for daily timing or weekly cycle timing. Click "✅" to start/cancel the scene setting.

Click the scene section to be modified to enter the scene modification, click the mode area "🌞🌧️🌨️" to change the mode, click the corresponding value to modify by keyboard input, click "✅" to start/cancel the scene setting. After setting, press "Enter" to save and confirm.

Scene operation: When the time reaches the set time, the operation mode and set temperature will automatically switch to the value set by the scene, but the state of switching on and off will not be changed.

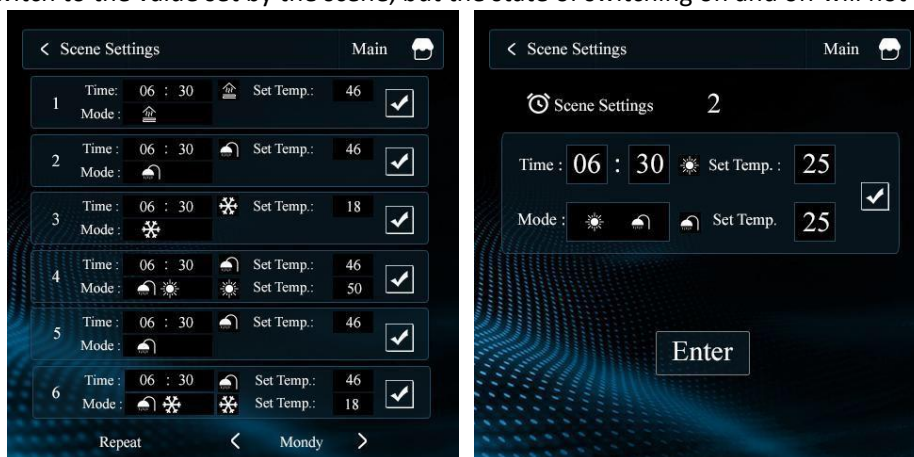

3.2.8.4. Query menu



(1) User parameter query

Set temperature, hysteresis, return water temperature, anti-virus.

In the bright screen state, press "  " to enter the query page, and then click

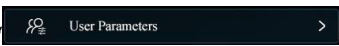
"  " to enter the user parameter list, the modification method refers to the factory parameter setting.

(2) Modification of operating parameters

When the screen is on, press "  " to enter the query page.

Click "  " to enter the temperature status view.

When the network is running, press "  " to enter the unit number and click on the corresponding online unit number to enter the temperature status query of the corresponding unit. Gray crew representatives are not online.

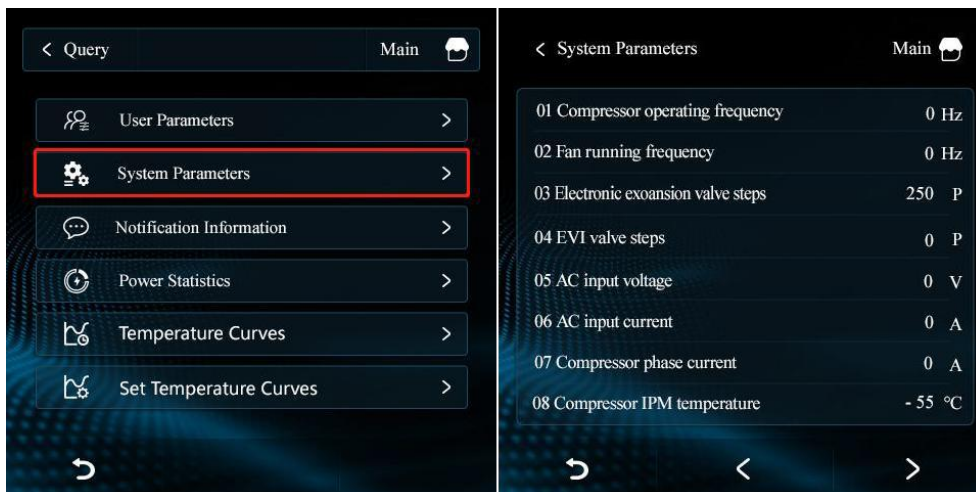

See the attached table for details of the operating parameters:



(3) Display failure

In the bright screen state, press "  " to enter the query page, and then click "

"  ".

Click "  " to view historical faults, click "  " to query current faults, and click "  " to clear historical faults.

Fault representative meaning:

00E03:

00 — the host;

01.02.03..... — the slave.

00E03:

E03 — fault code.



(4) Power module parameter query (optional)

When the machine is equipped with a power module, press "  " to enter the query page when the screen is on.

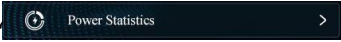
Click "  " to enter the power consumption information query of the unit, and you can query the total power consumption, current power, voltage, and current parameters.

(5) Curve query

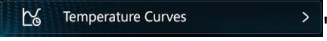

When the screen is on, press "  " to enter the query page.

Click "  " to enter the curve query, which can record the curve of 4 parameters including water inlet, water outlet, compressor frequency and ambient temperature within 24 hours.

(6) Temperature curve setting

In the bright screen state, press "  " to enter the query page, and then click "

 " to enter the curve setting.

Click "  " and "  " below to switch the curve settings of different modes.

Click "  " to select different curve controls, and the specific parameters of the current curve will be displayed in the curve area.

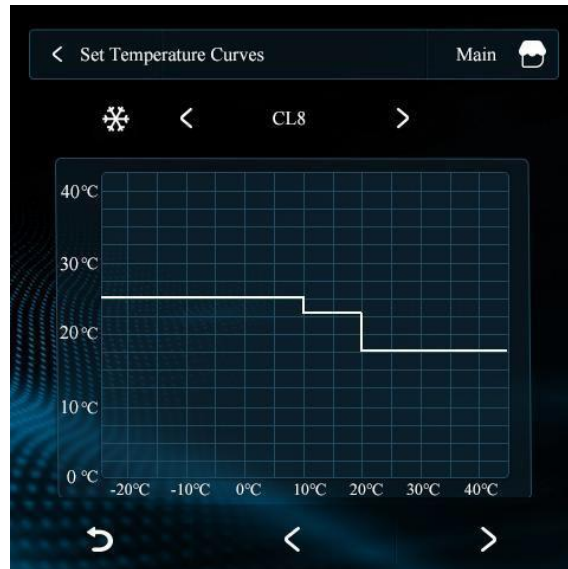

3.2.8.5. Setting menu



(1) Clock setting



When the screen is on, press "⚙️" to enter the setting page.

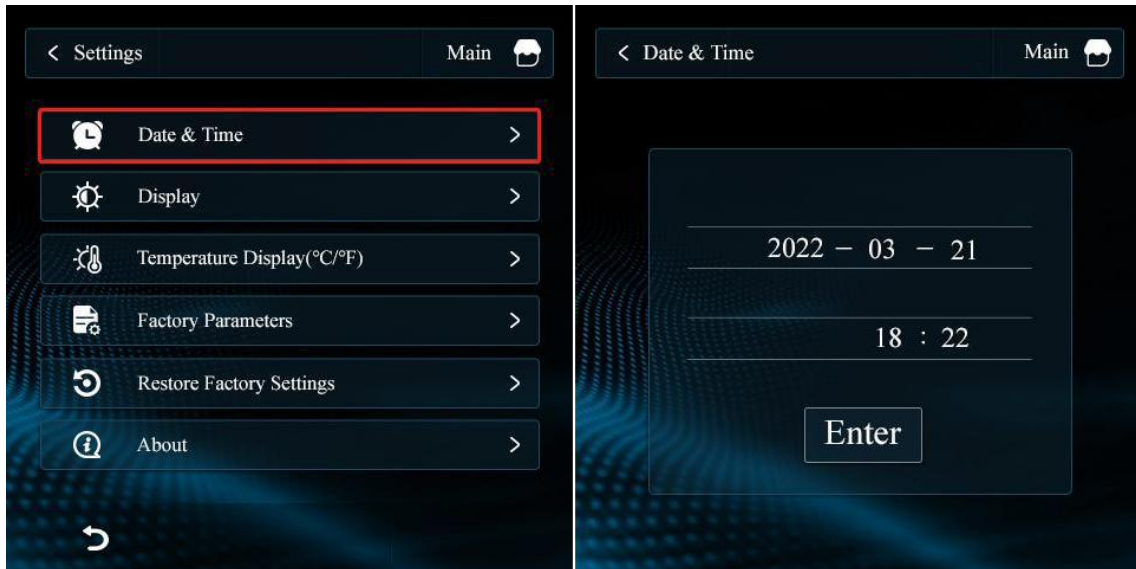

Click "🕒 Date & Time >" to enter the time setting page.

Click the corresponding year, month, and day to enter the value through the keyboard, and finally press "Enter" to save the time.



(2) R/C Brightness and Language Settings

When the screen is on, press "  " to enter the setting page, then click "  Display > "

to enter the brightness setting interface, slide the slider to set different brightness. Click "  "and"  "to switch between different languages, (Chinese, English, Polish.)

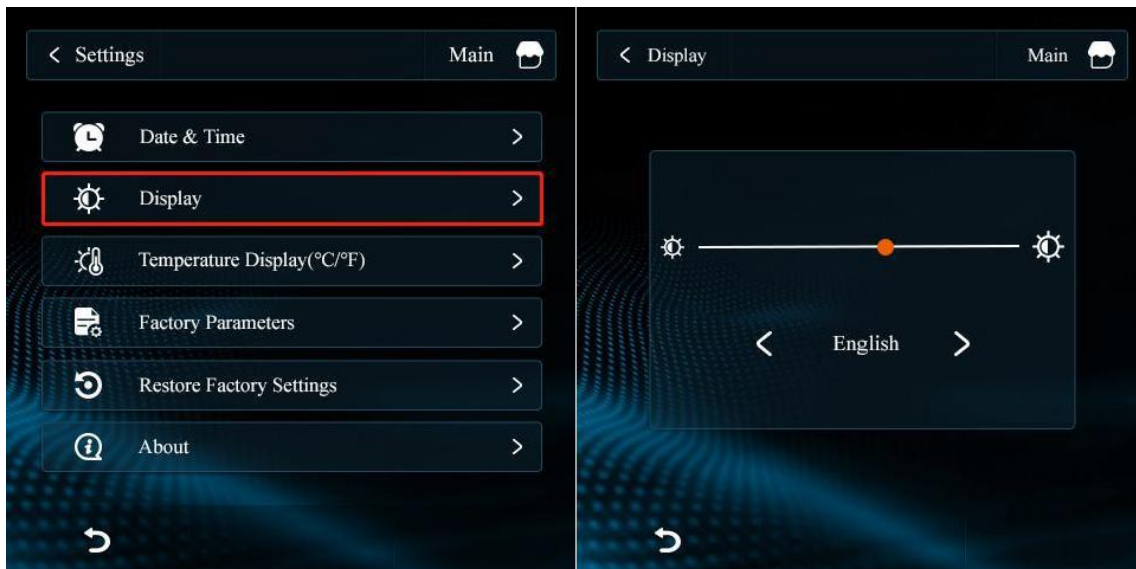

(3) Parameter settings

In the bright screen state, press "  " to enter the setting page, and then click "

 Factory Parameters > " to enter the parameter setting page.

When the network is running, press "  Factory Parameters > ". Enter the unit number selection Click the corresponding online unit number to enter the parameter setting of the corresponding unit. Gray crew representatives are not online.

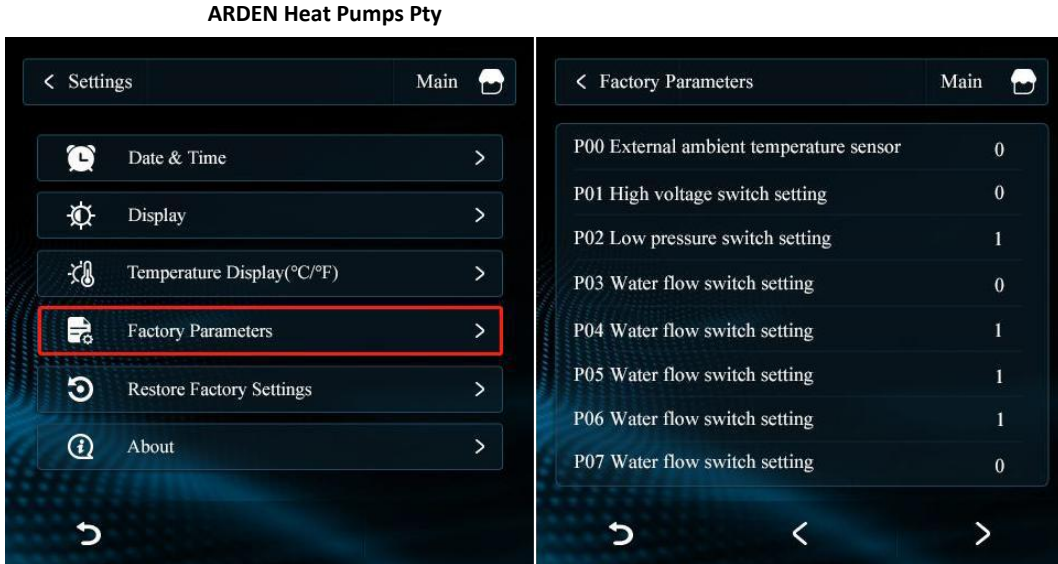

At this time, you can press "**>**" and "**<**" to turn the page to view the value of each parameter, and click the parameter to be modified to enter the parameter modification page.

On this page, the parameter number, current parameter value, setting value, and setting range can be displayed. Click the parameter value to enter the set value on the pop-up keyboard and press "Enter", and then press "Enter" to save the parameter on the page shown below. Press "**>**" and "**<**" to switch to the next parameter.

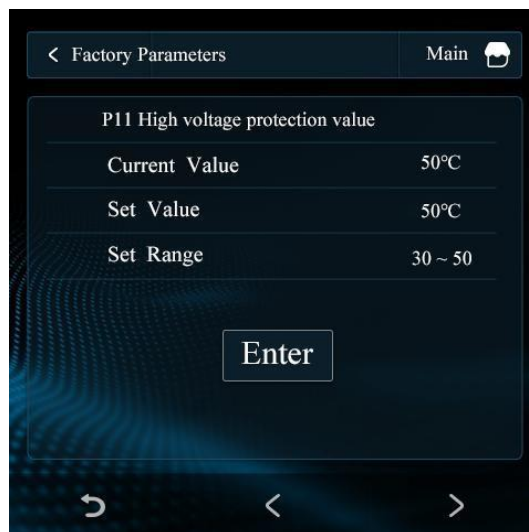

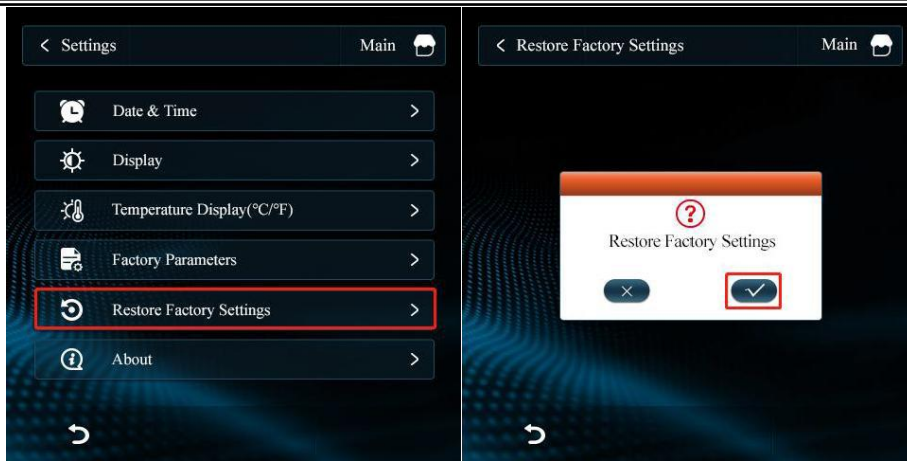

(4) Reset

In the bright screen state, press "**⚙️**" to enter the setting page, then click "**🔄 Restore Factory Settings >**" to enter the factory reset page, and then click "**✅**" to restore the factory settings.



(5) View the program version

When the screen is on, press "  " to enter the setting page, and then click "

 About " to view the program version numbers of the display and mainboard.

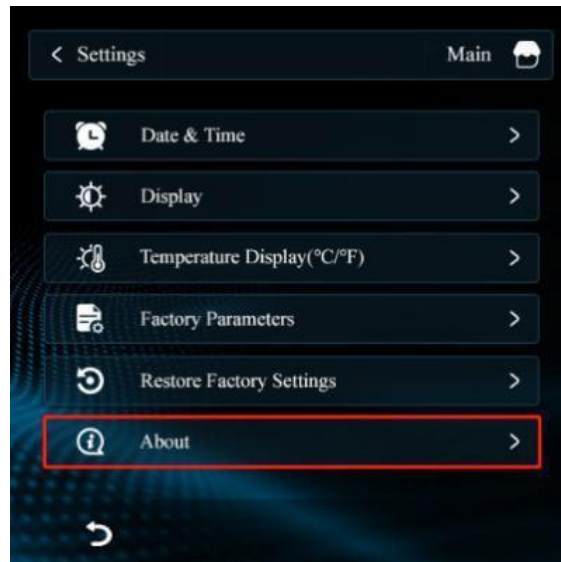

L parameter setting table

NO.	Parameter Description	Factory parameters	range	Note
L0	Compressor manual control	0	0~1	0 automatic, 1 manual
L1	Compressor target frequency	0Hz	0~120Hz	
L2	Fan manual control	0	0~1	0 automatic, 1 manual
L3	Fan target frequency	0	0~70	0-70Hz (when PO6 chooses 1)
				Taps: 0 stop, 1 low, 2 medium, ≥3 high wind
L4	Electronic expansion valve manual control	0	0~1	0 automatic, 1 manual
L5	Electronic expansion valve target steps	0	0~1	0-480P
L6	EVI manual control	0	0~1	0 automatic, 1 manual
L7	EVI target steps	0	0~1	0-480P
L8	DC water pump control	0	0~1	0 automatic, 1 manual
L9	DC water output	0	0~100	0 minimum output/100 maximum output
L10	PFC manual control	0	0~2	0 auto, 1 off, 2 on
L11				
L12	High temperature sterilization function	0	0~2	0 automatic, 1 disabled, 2 manual
L13	Sterilization interval days	7	5~30 days	
L14	Sterilization start time	23:00	00:00-24:00	
L15	Sterilization run time	10	0-50Min	
L16	Sterilization temperature setting	70°C	50-80°C	
L17	water level control	1		0 Disabled/1 High Low/2 High High Low
L18	Hydration Control	2		0 water level control/1 water temperature + water level control
L19	Allow water temperature	45		
L20	Hysteresis of replenishment water temperature	5		
L21	Low water cut-off operation			0 not start/1 power on not start/2 start
L22	Backwater mode (host)	0	0~3	0: disabled/1 continuous return water/2 cycle return water/3 temperature difference return water
L23	Inlet water temperature T8 (host)	40°C	20~65°C	
L24	Return water hysteresis (host)	5°C	1~15°C	
L25	Backwater cycle (host)	30min	3~90min	
L26	Return time (host)	5min	1~30min	
L27				
L28				
L29				
L30			0	

L31				
L32				

Table3-4

P parameter setting table

NO.	Parameter Description	range	Note
P00	reserve	0~1	
P01	High voltage switch setting	0~1	0 enables, 1 disables
P02	Low pressure switch setting	0~1	0 enables, 1 disables
P03	Water flow switch setting	0~1	0 enables, 1 disables
P04	Thermal overload protection switch setting	0~1	0 enables, 1 disables
P05	Linkage switch setting (host)	0~2	0 enable, 1 disable, 2 constant temperature control
P06	Fan type setting	0~1	0 AC, 1 DC, 2EC fans
P07	High voltage protection lock setting	0~1	0: 3 locks, 1: no lock
P08	Low voltage protection lock setting	0~1	0: 3 locks, 1: no lock
P09	Exhaust protection lock setting	0~1	0: 3 locks, 1: no lock
P10	Water flow switch protection lock setting	0~1	0: 3 locks, 1: no lock
P11	High voltage protection value	40~70	
P12	High frequency limit value	40~70	The setting value must be ≤ P11-5
P13	Low voltage protection value	-50~-10	
P14	Low voltage frequency limit value	-50~-10	
P15	Exhaust temperature protection value	100~120	
P16	Exhaust temperature frequency limit value	90~120	The setting value must be ≤ P15-10
P17	Cooling fan speed increase value	0~60	
P18	Cooling fan speed reduction value	0~60	
P19	Heating fan speed reduction value	0~60	
P20	Heating fan speed increase value	0~60	
P21	Low temperature value for unit prohibited from starting (host)	-40~-10	
P22	Electric heating start ambient temperature (host)	-15~40	≤P22 start
P23	Excessive temperature difference between inlet and outlet water (host)	10~30	≥ alarm
P24	Inlet water temperature T8 compensation value (host)	-10~10℃	
P25	Outlet water temperature T15 compensation value (host)	-10~10℃	
P26	Air conditioning return difference (host)	0~10℃	
P27	Floor heating return difference (host)	0~10℃	
P28	Water pump control (host) when the temperature reaches the shutdown	0~4	0 running/1 stop/2 cooling running/3 air conditioning running/4 floor heating running
P29	Antifreeze water pump running time (every 81	0~10min	

ARDEN Heat Pumps Pty

	10min)		
P30	Defrost mode selection	0~2	0 smart, 1 timing, 2 fast
P31	Enter the threshold value of the accumulated running time of defrosting	0~120	
P32	Enter the defrost coil temperature value	-30~0	
P33	Enter the defrost temperature difference 1	0~20	
P34	Enter the defrost temperature difference 2	0~20	
P35	Maximum defrost time	0~30	
P36	Exit defrost coil temperature	0~30	
P37	Darwin Shutdown Mode (Host)	0~2	0 Smart, 1 Darwin, 2 Refrigeration Smart
P39	Pressure Sensor Settings	0~1	0 enable, 1 disable
P43	MV switch setting	0/1	1 enables, 0 disables
P44	Water flow switch failure detection settings	0/1	0 enables, 1 disables
P45	Communication address code	1~16	
P51	Refrigeration minimum frequency limit	15-60Hz	
P52	Refrigeration target frequency upper limit	40-120Hz	
P53	Cooling target frequency lower limit	15Hz-P52	
P55	Heating target frequency upper limit	50-120Hz	
P56	Heating target frequency lower limit	20Hz-P55	
P57	Heating minimum frequency 1	15-60Hz	Ambient temperature > 0°C
P58	Heating minimum frequency 2	15-60Hz	-10°C ≤ Ambient temperature < 0°C
P59	Heating minimum frequency 3	15-60Hz	Ambient temperature < -10°C
P61	Hot water target frequency upper limit	50-120Hz	
P62	Hot water target frequency lower limit	15Hz-P61	
P63	Hot water minimum frequency 1	15-60Hz	Ambient temperature > 0°C
P64	Hot water minimum frequency 2	15-60Hz	-10°C ≤ Ambient temperature < 0°C
P65	Hot water minimum frequency 3	15-60Hz	Ambient temperature < -10°C
P66	DC fan initial frequency	20-60Hz	Speed = frequency * 15
P67	DC fan heating minimum frequency	20-60Hz	Speed = frequency * 15
P68	DC fan heating maximum frequency	20-60Hz	Speed = frequency * 15
P69	DC fan cooling minimum frequency	20-60Hz	Speed = frequency * 15
P70	DC fan cooling maximum frequency	20-60Hz	Speed = frequency * 15
P88	Quiet Mode Compressor Frequency	20-70Hz	
P89	Quiet Mode Fan Frequency	20-60Hz	Speed = frequency * 15
P95	Network pump operation mode	0-1	0: shared, 1: independent
P96	Hot water return difference (host)	0~10°C	
P99	Water pump speed regulation temperature difference	2~10°C	
P100	PWM water pump minimum speed	20~80%	speed percentage
P101	Water pump control mode (host)	0~1	0 AC, 1 DC PWM speed regulation

ARDEN Heat Pumps Pty

P103	Mode switching minimum run time	0~10min	When set to 0, it means unlimited
P105	Cooling mode operating ambient temperature limit (host)	10~60°C	
P106	Operating ambient temperature limit in heating mode (host)	10~60°C	Underfloor heating or heating
P107	Hot water mode operating ambient temperature limit (host)	10~60°C	
P108	Hot water setting temperature upper limit (host)	30~80°C	
P109	Hot water setting temperature lower limit (host)	10~30°C	
P110	Heating set temperature upper limit (host)	30~60°C	
P111	Heating set temperature lower limit (host)	15~30°C	
P112	Refrigeration set temperature upper limit (host)	20~40°C	
P113	Cooling set temperature lower limit (host)	5~20°C	
P114	Selection of the number of presses	1~2°C	1 single, 2 pairs
P115	Model Selection (Host)	0~5	0: Double supply, 1: Triple supply reserved for 2/3/4/5
P116	Unit temperature control mode (host)	0~1	0: return water/1: discharge water
P117	Freeze protection into ambient temperature	0~10°C	
P118	Antifreeze into the outlet water temperature T15	0~20°C	
P119	Refrigerant type	0~20	1: R410A, 2: R32, 3: R290
P120	Cold start limit	0~1	0 enables, 1 disables
P134	Low water flow protection value	0~100	0 is not detected
P135	Anti-condensation starting temperature difference	0~50	Valid when P120 = 0
P136	Throttle bypass valve open ambient temperature	-20~50	
P137	Throttle bypass valve delay press	0~999	
P138	Defrost press frequency	40~120	
P139	Air conditioner heating option	0/2	0 enable, 1 disable, 2 gas control
P140	Hot water heating options		0 enable, 1 disable, 2 gas control
P141	Duration of defrosting dew point	0~60	min
P142	Defrosting dew point constant		
P143	Defrost can enter the water temperature		°C
P144	Defrost can enter ambient temperature	-20~30	°C
P145	Outlet water antifreeze protection value	-30~10	antifreeze probe
P146	Pump range setting value	0~100L/min	Set the maximum range value according to the pump model
P147	Refrigeration and antifreeze mode	2000/1/2	0 low pressure, 1 temperature, 2 low pressure + temperature

ARDEN Heat Pumps Pty

P148	Refrigeration antifreeze temperature value	-40	Fluorine way in/out
P149	Excessive water output frequency limit	40-80	
P150	Secondary heating pump selection	2	
P151	Hysteresis difference of hot water heat source	0	
P152	Hysteresis difference of heating heat source	0	
P153	Combined temperature upper limit of hot water heat source	70	
P154	Heating heat source joint temperature upper limit	60	
P155	Compressor code selection (function reserved)	0	See compressor code table, 0: disabled
P158	Heating limited outlet water temperature, starting ambient temperature	-15	Disabled when set to 30
P161	Auxiliary pump selection	0	0: hot water/1: air conditioner/2: floor heating/3: air conditioner/floor heating/4: all
P162	Antifreeze time interval of hot water pipeline	90	Disabled when set to 0, unit: min
P163	Water pump speed regulation minimum flow	30	L/min
P164	energy level control	3	0 all enabled/1 hot water enabled/2 heating enabled/3 all disabled
P165	Load hysteresis	3	
P166	Load shedding hysteresis	2	
P167	emergency stop	3	
P168	Hot water mode start ratio	50	
P169	Non-hot water mode startup ratio	100	
P170	load cycle	7	
P171	Shielded low-voltage switch ring temperature value	-30	
P174	Defrost opening	450	

Table3-5

3.3. Setting method of pump flow range setting value

The parameter setting value of P146 determines whether the feedback flow value of the 25 state parameters is accurate. Different pump models have corresponding setting values. See the table below for details:



P146=62		P146=75		
SHIMGE				
APF25-12-130E FPWM1		APM25-9-130		
BLN-018TC1	BLN-018TC3	BLN-006TC1	BLN-012C1	BLN-012C3
				

Table3-6

3.4. Outdoor unit electric control box layout

3.4.1. BLN-006TC1

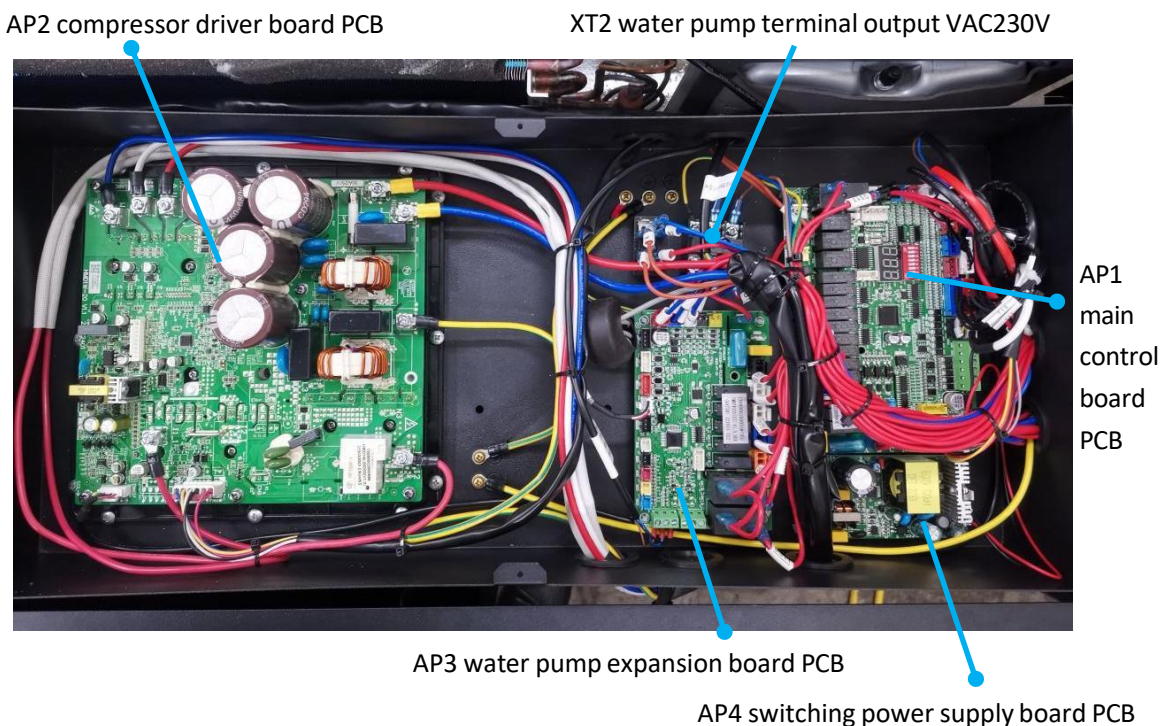

3.4.2 BLN-012TC1

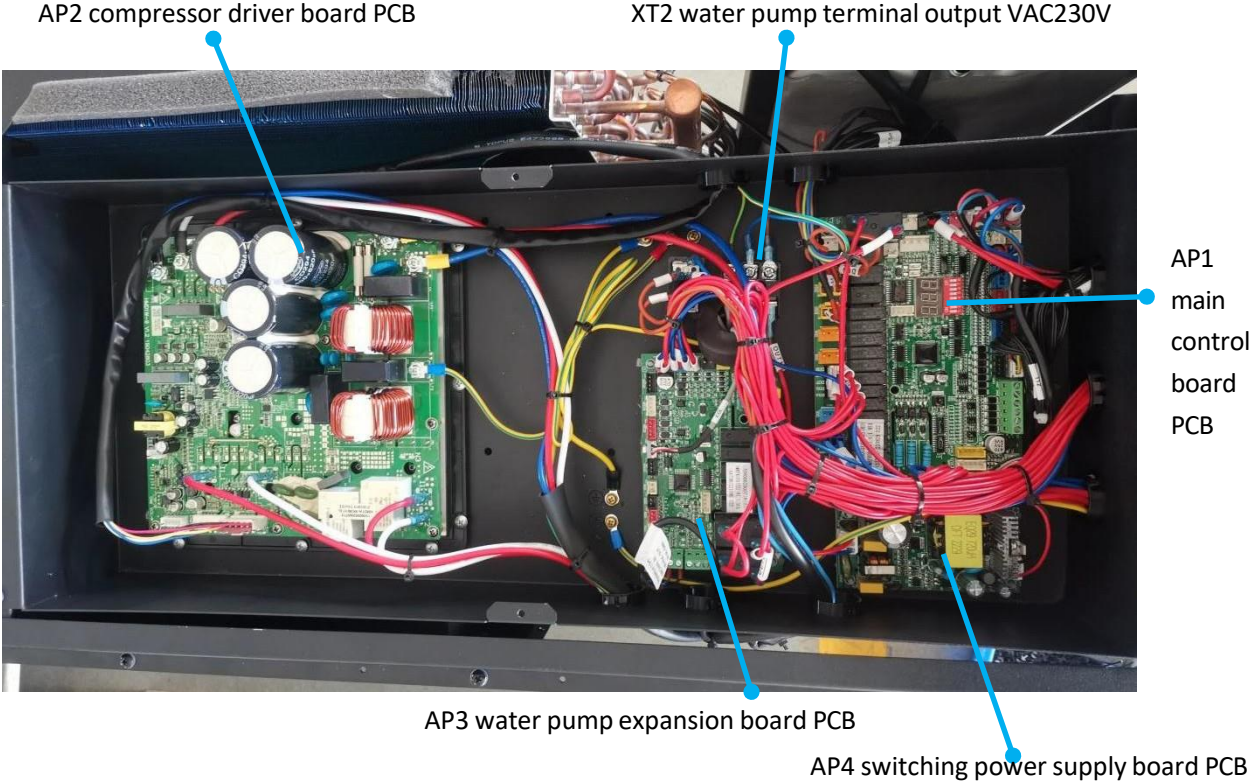

3.4.3. BLN-006TC1/ BLN-012TC1/ BLN-018TC1

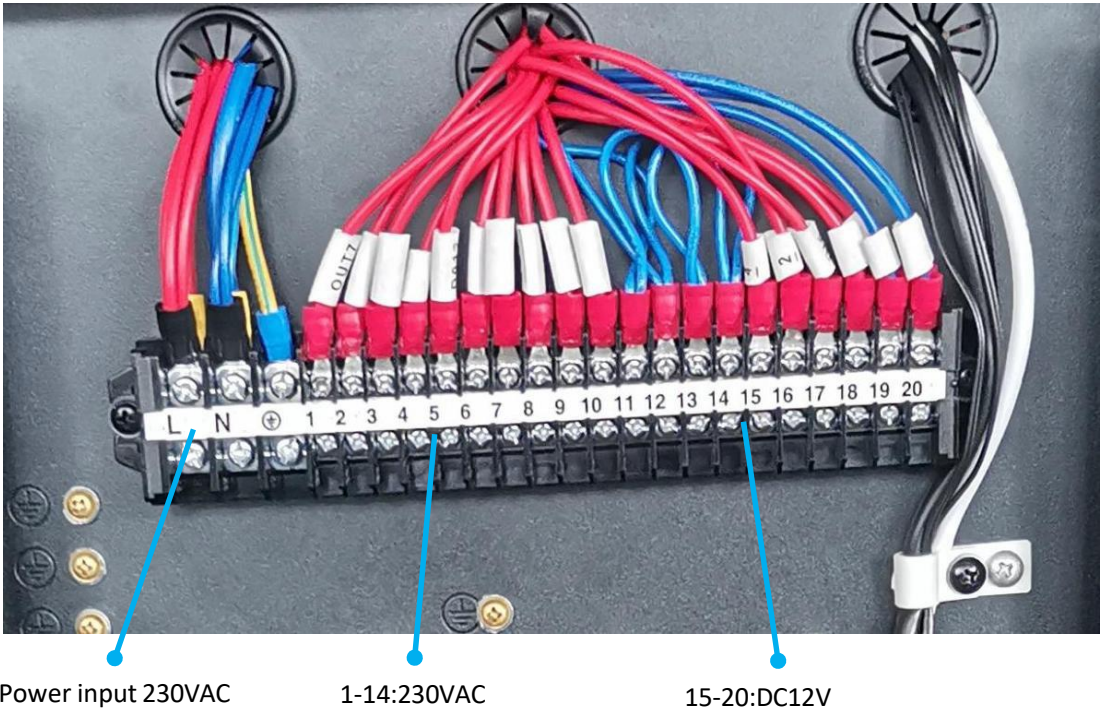

3.4.4. BLN-012TC3

AP2 compressor driver board PCB AP5 DC fan board PCB XT2 water pump output terminal VAC230V



AP1
main
control
board
PCB

AP3 water pump expansion board PCB AP4 switching power supply board PCB

3.4.5. BLN-018TC3

AP4 switching power supply board PCB AP3 water pump expansion board PCB AP2 Compressor Driver Board

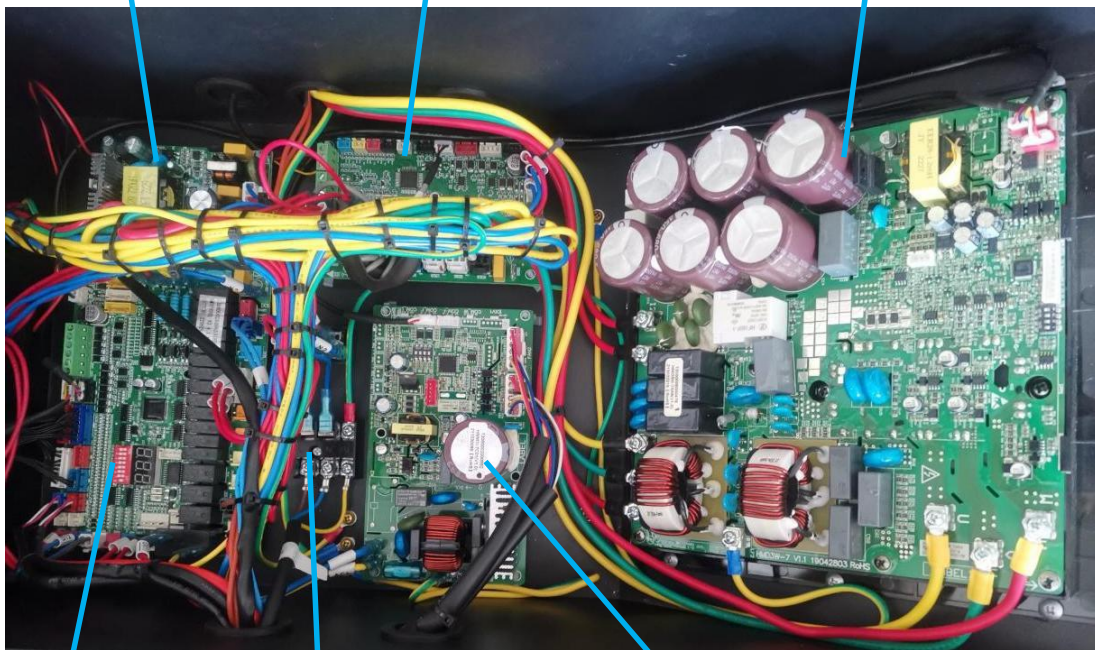

AP1 main control board PCB

XT2 water pump output
terminal VAC230V

AP5 DC fan board PCB

3.1.6. BLN-012TC3/BLN-018TC3

AP1 main control board PCB and wire controller communication line

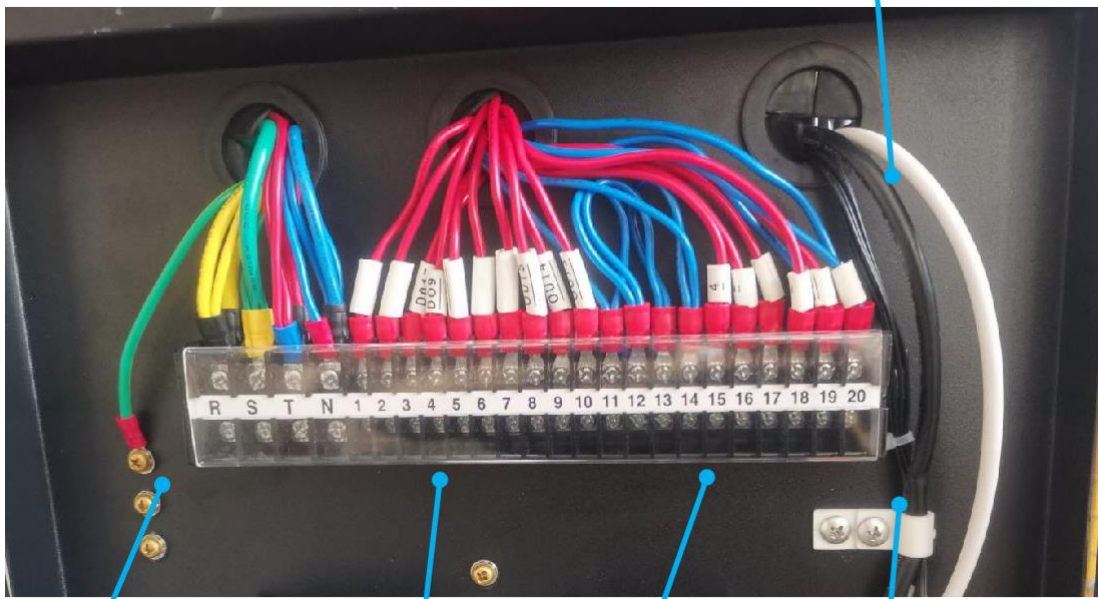

XT1 power input 400VAC 1-14: 230VAC 15-20: DC12V NTC temperature sensor (5K)

3.5. Host unit port definition diagram

3.5.1. Main control board port definition diagram (AP1)

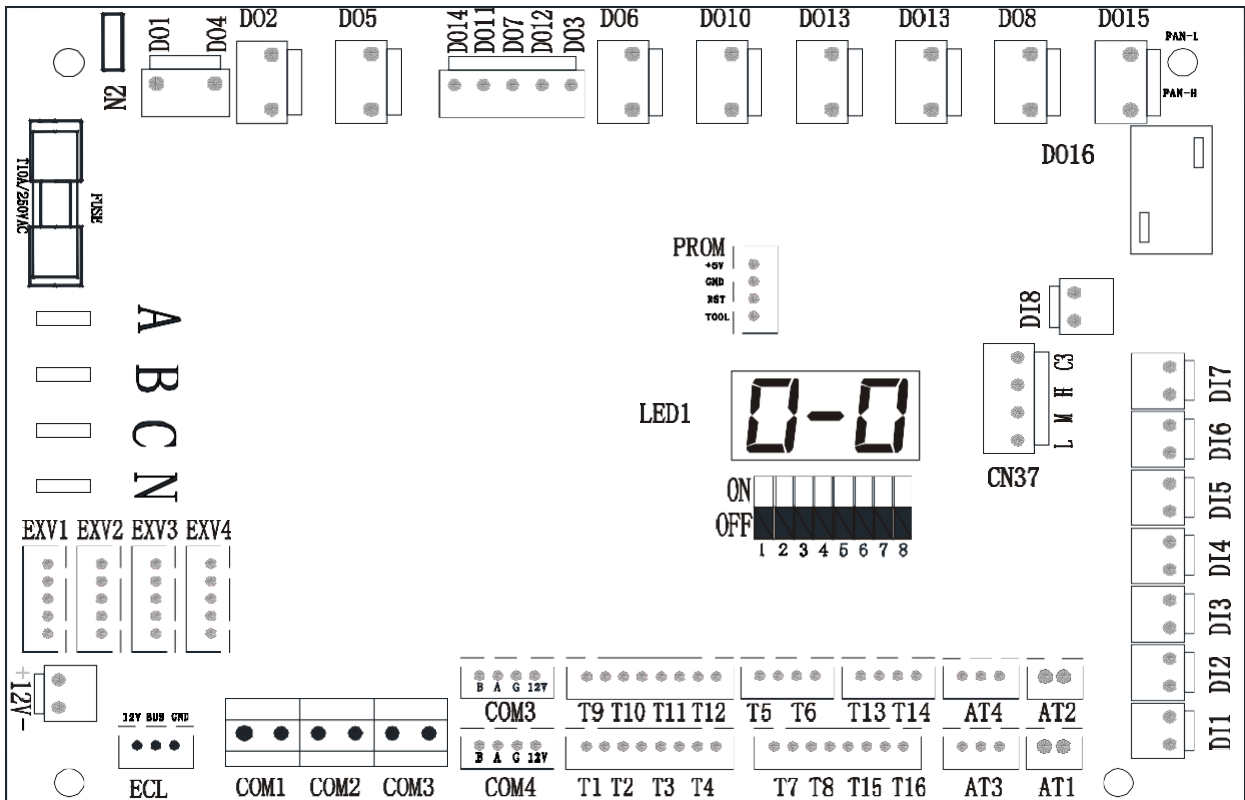

port	Description	port	Description	port	Description
D01	Hot water electric heating/gas signal output	D13	Flow switch	AI3	low pressure sensor
D02	Four-way valve	D12	low voltage switch	T1	Outer coil temperature
D03	Liquid spray valve	D11	High voltage switch	T2	return air temperature

ARDEN Heat Pumps Pty

D04	Throttle bypass valve	C3	water level common	T3	Exhaust gas temperature
D05	reserve	H	High water level (hot water)	T4	Cooling coil temperature
D06	return valve	M	Medium water level (hot water)	T5	Economizer inlet temperature
D07	crankshaft heating	L	low water level (hot water)	T6	Economizer outlet temperature
D08	chassis heating	AI2	reserve	T7	outdoor ambient temperature
D09	heating electric heating	AI1	reserve	T8	Inlet water temperature
D010	EH3: expansion tank heating	AI4	High pressure sensor	T9	Total outlet water temperature sensor (optional)
D011	P_e: hot water side auxiliary heat source pump	COM3	driver module	T10	Heating water tank temperature sensor (optional)
D012	P_f: Auxiliary heat source pump on the heating side	COM4	LCD wire controller	T11	Heating side heat source temperature sensor (optional)
D013	EH4: plate replacement electric heating	COM3	reserve	T12	Hot water side heat source temperature sensor (optional)
D014	Enthalpy increasing valve	COM2	Host computer monitoring	T13	User return water temperature
D015	low wind	COM1	module cascading	T14	Antifreeze temperature
D016	high wind	ECL	extension module	T15	water temperature
D017	P_c hot water auxiliary pump (optional)	12V	DC 12V power supply	T16	Water tank temperature (hot water)
C2	public port 1	EXV1	EEV main valve	LED1	Digital Tube
C1	Common 2	EXV2	EVI auxiliary valve	SW1	DIP switch
DI8	Medium voltage switch 1	C	Power input T phase	N	Power input zero line
DI7	reserve	B	Power input S phase		
DI6	Host linkage switch	A	Power input R phase		

Table3-9

3.5.2. Port Definition Diagram of Water Pump Expansion Board (AP3)

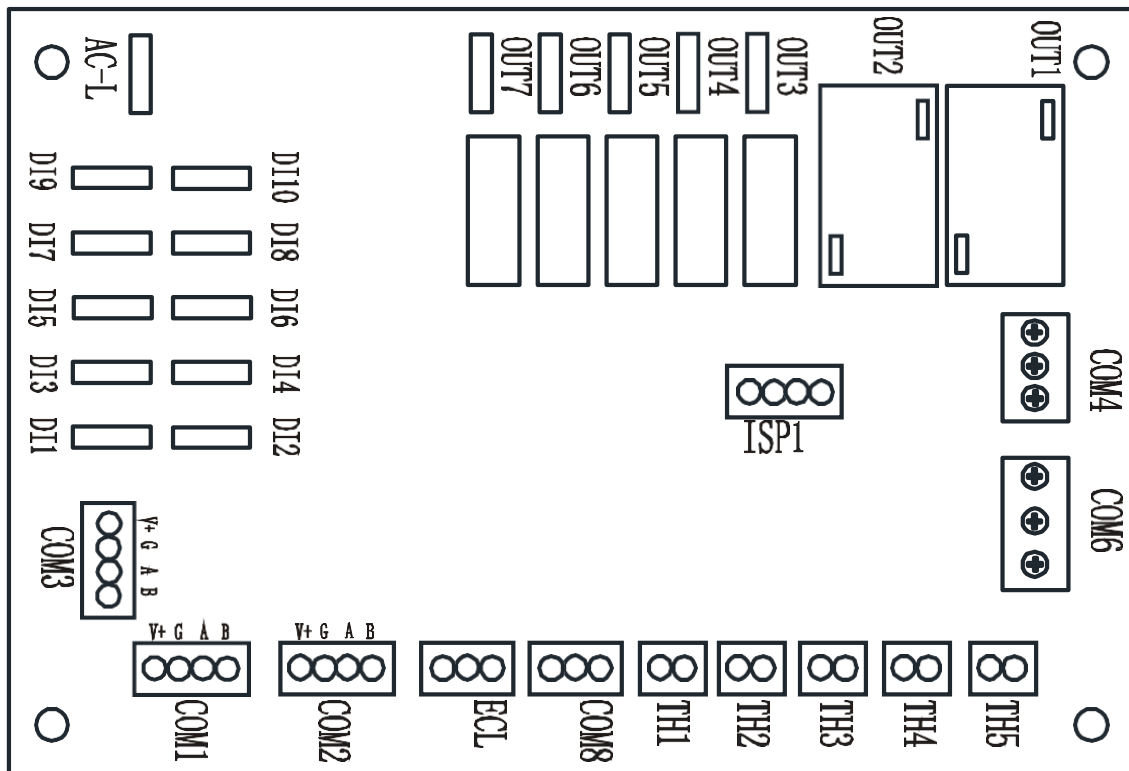

NO.	port	Description	NO.	port	Description
-----	------	-------------	-----	------	-------------

ARDEN Heat Pumps Pty

1	OUT1	Circulating pump	18	DI6	Heating secondary circulation pump linkage switch
2	OUT2	P_b: heating secondary circulation pump	19	DI5	GND
3	OUT3	SV1: Air conditioner valve closed	20	DI4	Heat source heating side linkage switch
4	OUT4	SV1: air conditioner valve open	21	DI3	GND
5	OUT5	SV2: hot water valve open	22	DI2	Heat source hot water side linkage switch
6	OUT6	SV2: hot water valve closed	23	DI1	GND
7	OUT7	Hot water electric heating/gas signal output	24	TH1	reserve
8	DI10	reserve	25	TH2	reserve
9	DI9	GND	26	TH3	reserve
10	DI8	reserve	27	TH4	reserve
11	DI7	GND	28	TH5	reserve
12	COM3	RS485	29	COM8	water flow meter
13	COM2	RS485	30	ECL	Communicate with the main control board
14	COM1	RS485	31	COM4	Indoor pump PWM input and output
15	AC-L	FireWire input	32	COM6	Host circulating pump PWM input and output

Table3-10

Spare motherboard

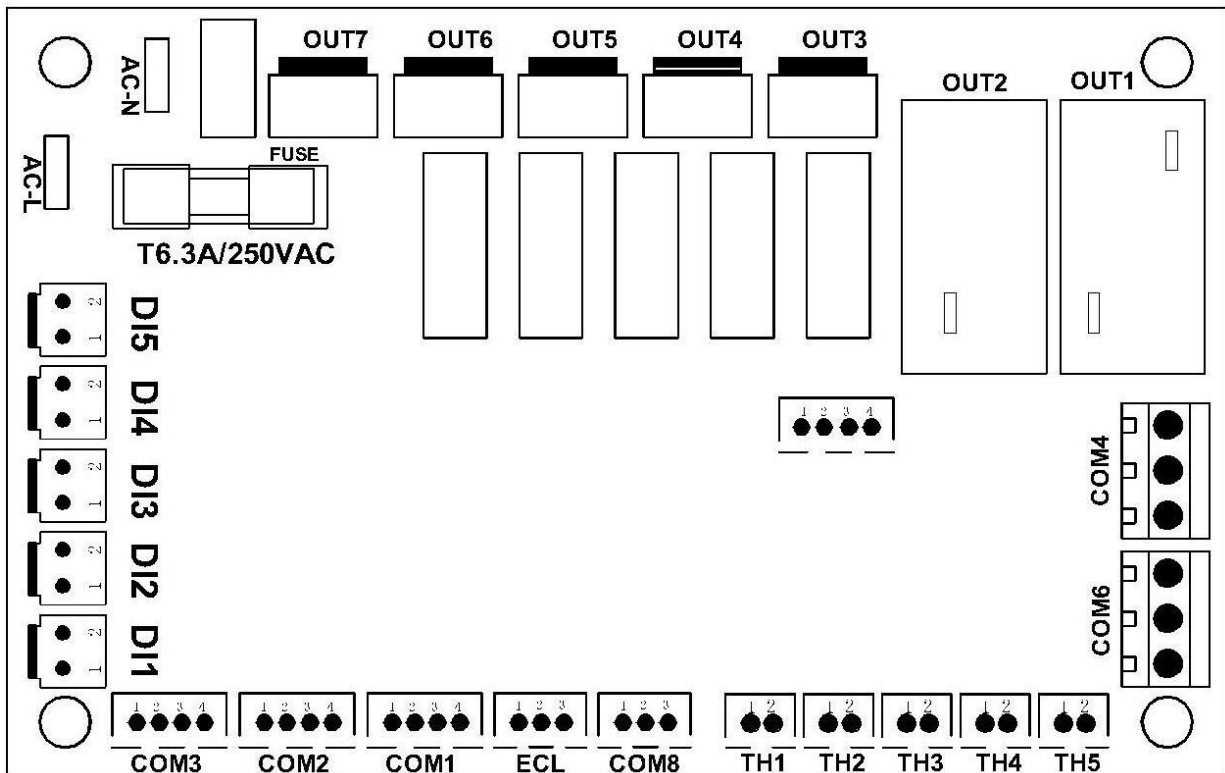

NO.	port	Description	NO.	port	Description
1	OUT1	Circulating pump	18	DI6	reserve
2	OUT2	P_b: heating secondary circulation pump	19	DI5	reserve

ARDEN Heat Pumps Pty

3	OUT3	SV1: Air conditioner valve closed	20	DI4	Heating secondary circulation pump linkage switch
4	OUT4	SV1: air conditioner valve open	21	DI3	Heat source heating side linkage switch
5	OUT5	SV2: hot water valve open	22	DI2	Heat source hot water side linkage switch
6	OUT6	SV2: hot water valve closed	23	DI1	GND
7	OUT7	Hot water electric heating/gas signal output	24	TH1	reserve
8	COM3	RS485	25	TH2	reserve
9	COM2	RS485	26	TH3	reserve
10	COM1	RS485	27	TH4	reserve
11	AC-L	FireWire input	28	TH5	reserve
12	AC-N	Neutral input	29	COM8	water flow meter
13			30	ECL	Communicate with the main control board
14			31	COM4	Indoor pump PWM input and output
15			32	COM6	Host circulating pump PWM input and output

Table3-11

3.5.3. Port definition diagram of switching power supply (AP4)



3.5.4. DC fan board port definition diagram (AP5)

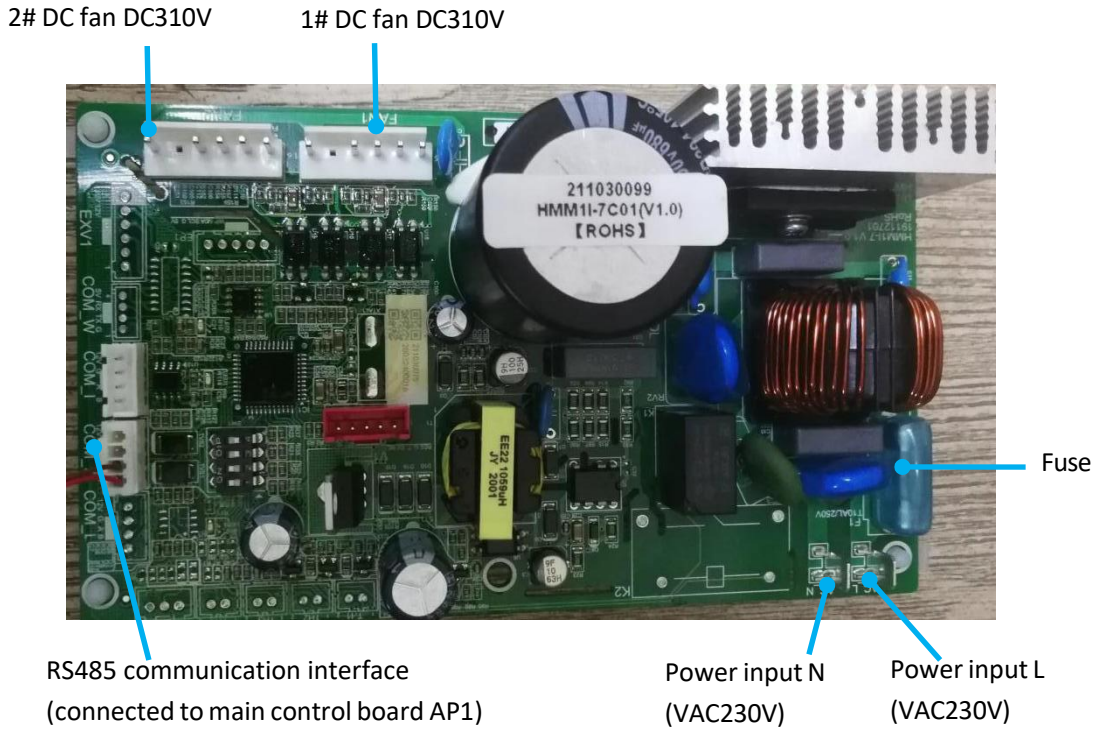

3.5.5. Compressor driver board port definition diagram (AP4) (1) For BLN-006/TC1

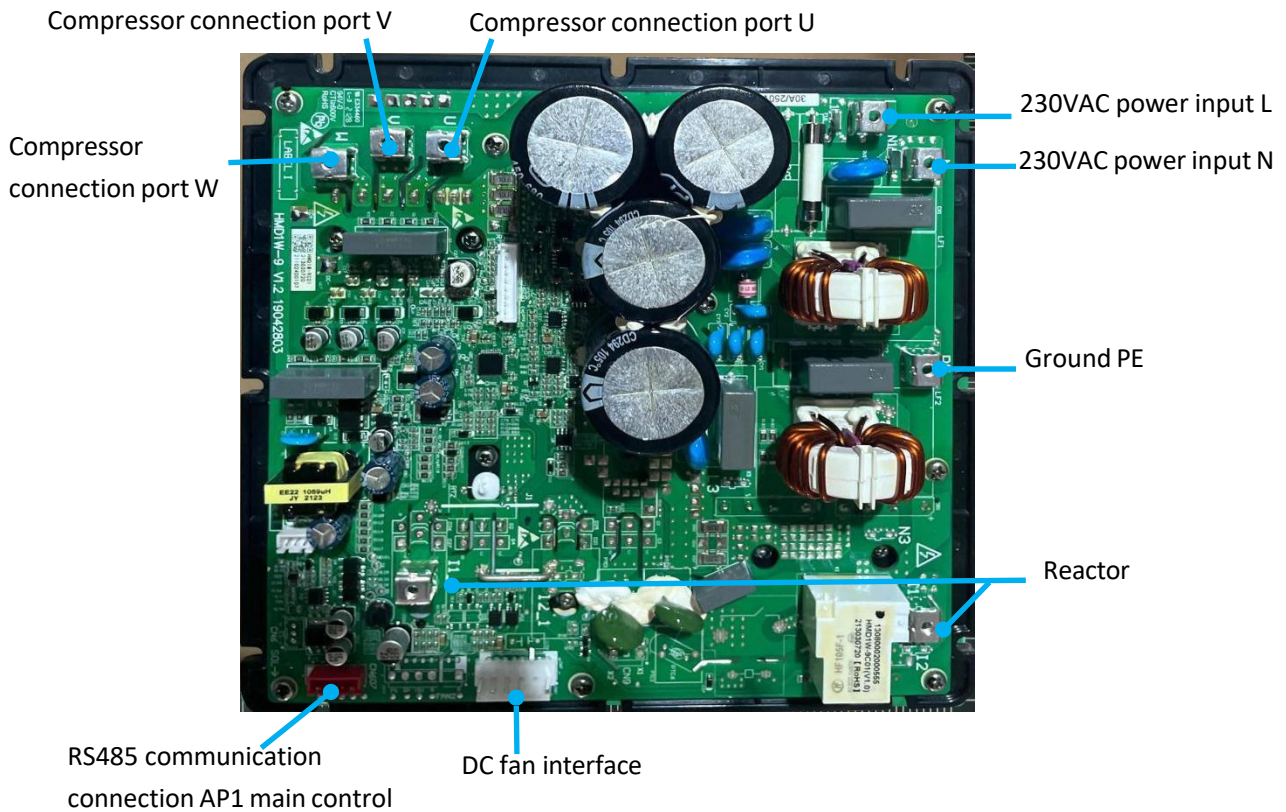

(2) For BLN-012/TC1 \ BLN-018/TC1

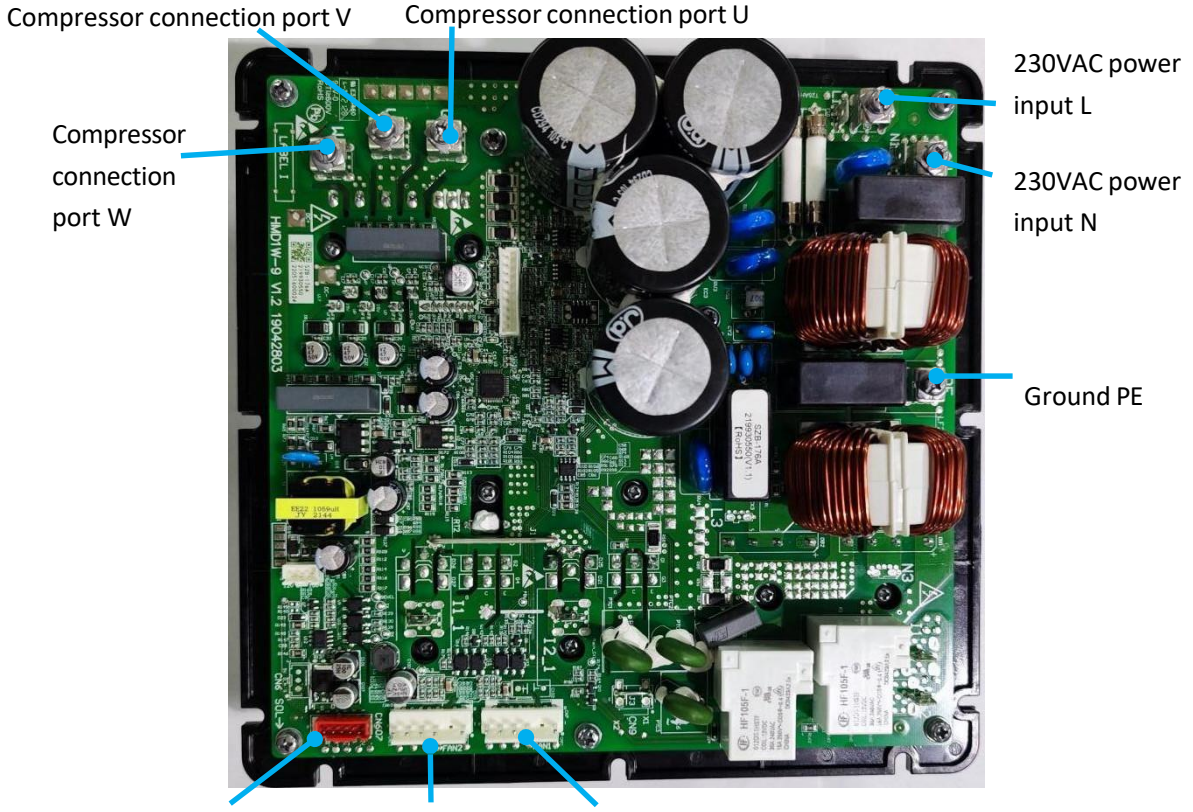

RS485 communication connection AP1 main control board

2# DC fan

1# DC fan interface

(3) For BLN-012/TC3 \ BLN-018/TC3

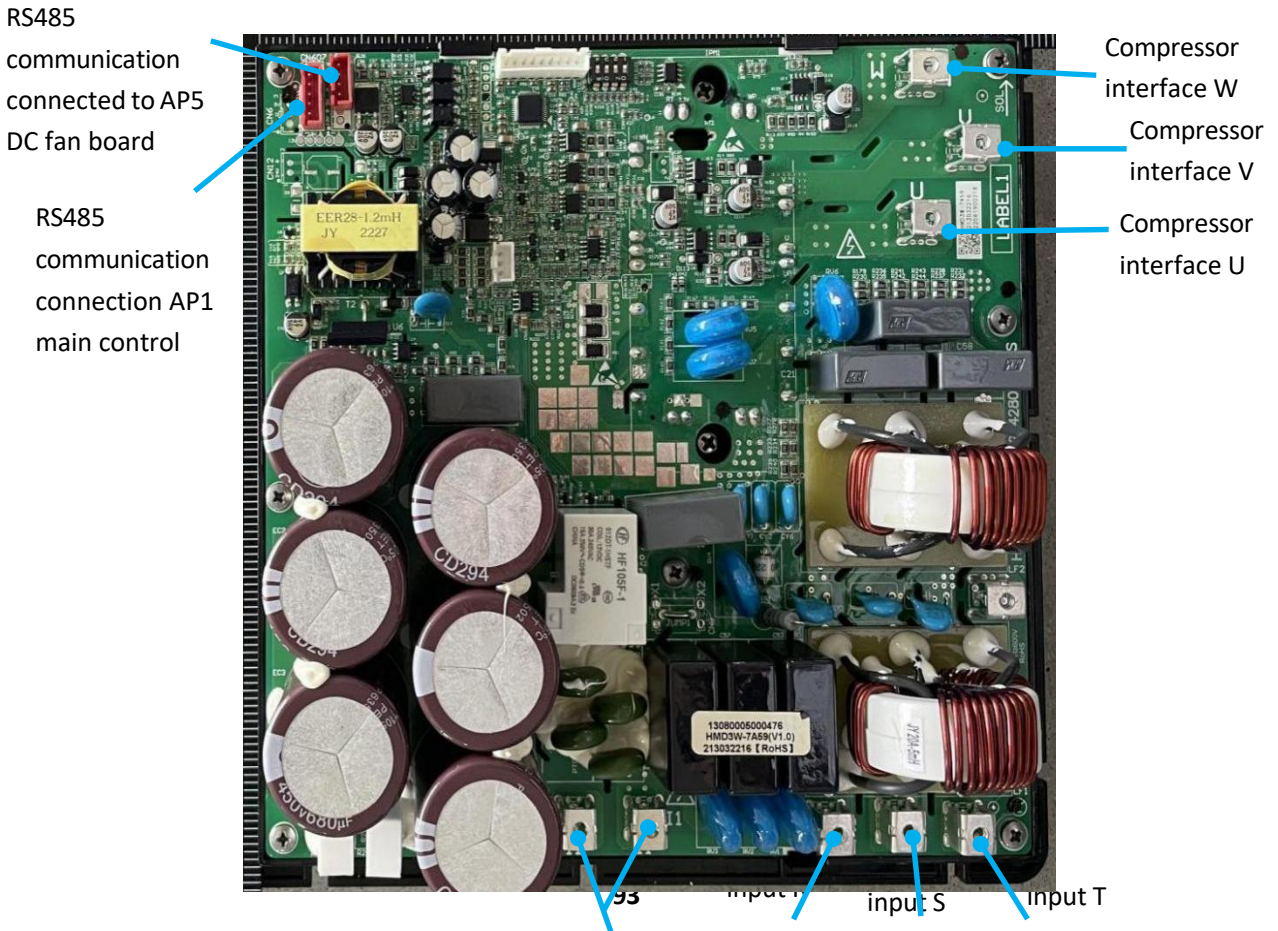

RS485 communication connected to AP5 DC fan board

RS485 communication connection AP1 main control

Compressor interface W
Compressor interface V
Compressor interface U

input S Input T

ARDEN Heat Pumps Pty

Reactor Power Power Power

AP1 main control board - temperature sensor T9/T10/T11/T12/T16 (enable and disable) :

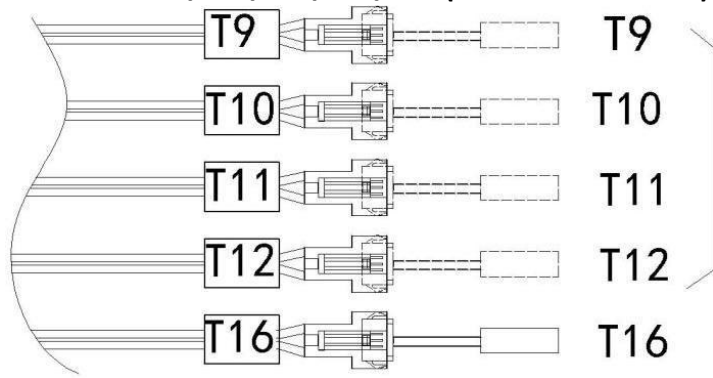
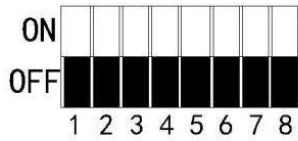

Optional external probe:

- (1) T9 total outlet water temperature is enabled, dial 7=ON (not enabled by default)
- (2) T10 heating water tank temperature is enabled, dial 6=ON (not enabled by default)
- (3) T11 heating side heat source temperature is enabled, P151 is set to non-0 (factory default 0 is not enabled)
- (4) T12 hot water side heat source temperature is enabled, P152 is set to non-0 (factory default 0 is not enabled)
- (5) T16 hot water tank temperature (factory standard configuration)

3.6. Fault code and fault reason

error code	Description	Troubleshooting and error causes
E 01	wrong phase protection	Power phase sequence error
E 02	Phase failure	Power phase loss
E 03	Water flow switch failure or low water flow protection	1. Whether the circulating water pump is normal and whether the water system is blocked
		2. Whether the model of the water flow switch is normal and whether the installation direction is correct
		3. Is the wiring of the water flow switch port correct?
		4. Whether the head of the water pump meets the actual requirements
		5. Whether the water pump is reversed, the installation direction is wrong
E 04	The communication between the main control board and the remote module is abnormal (reserved)	Check the communication connection between the motherboard and the remote module
E 05	High voltage switch failure	1. Whether the pressure switch is damaged or the wiring is wrong
		2. Too much refrigerant in the system
		3. Whether the fan is working normally and whether the water flow of the unit is normal
		4. The air in the fluorine system may be blocked
		5. Is the water side heat exchanger consolidating seriously?

ARDEN Heat Pumps Pty

E 06	Low voltage switch failure	1. Whether the pressure switch is damaged and whether the wiring is correct
		2. Lack of refrigerant in the system
		3. Is the fan working normally?
		4. There is blockage in the fluorine system
E 09	Communication failure between the wire controller and the main board	Check the communication connection between the wire controller and the motherboard
E 10	reserve	reserve
E 11	limited time protection	The free trial period has expired, enter the power-on password
E 12	Excessive exhaust temperature fault	1. The fluorine system is blocked
		2. There is a lack of refrigerant in the fluorine circuit system or the sensor is broken
E 14	Hot water tank temperature failure	1. The sensor cable is disconnected or short-circuited
		2. The sensor is damaged
		3. The motherboard port is damaged
E 15	Inlet water temperature sensor failure	1. The sensor cable is disconnected or short-circuited
		2. The sensor is damaged
		3. The motherboard port is damaged
E 16	Coil sensor failure	1. The sensor cable is disconnected or short-circuited
		2. The sensor is damaged
		3. The motherboard port is damaged
E 18	Exhaust sensor failure	1. The sensor cable is disconnected or short-circuited
		2. The sensor is damaged
		3. The motherboard port is damaged
E 20	Indoor temperature sensor failure	1. The sensor cable is disconnected or short-circuited
		2. The sensor is damaged
		3. The motherboard port is damaged
E 21	Environmental sensor failure	1. The sensor cable is disconnected or short-circuited
		2. The sensor is damaged
		3. The motherboard port is damaged
E 22	User return water sensor failure (hot water)	1. The sensor cable is disconnected or short-circuited
		2. The sensor is damaged
		3. The motherboard port is damaged
E 23	Refrigeration overcooling protection	1. Check whether the water flow is too low or no water flow
		2. Check whether the water outlet probe is damaged
		3. The fluorine system is blocked

ARDEN Heat Pumps Pty

E 24	Fluorine circuit antifreeze temperature failure (fluorine circuit)	1. The sensor cable is disconnected or short-circuited
		2. The sensor is damaged
		3. The motherboard port is damaged
E 25	reserve	reserve
E 26	Faulty antifreeze sensor (waterway)	1. The sensor cable is disconnected or short-circuited
		2. The sensor is damaged
		3. The motherboard port is damaged
E 27	Faulty water sensor	1. The sensor cable is disconnected or short-circuited
		2. The sensor is damaged
		3. The motherboard port is damaged
E 29	Return air sensor failure	1. The sensor cable is disconnected or short-circuited
		2. The sensor is damaged
		3. The motherboard port is damaged
E 30	Return air sensor failure	1. The sensor cable is disconnected or short-circuited
		2. The sensor is damaged
		3. The motherboard port is damaged
E 31	Water pressure switch failure	1. Water pressure switch wiring error
		2. Water pressure switch failure
E 32	Outlet water temperature is too high protection	1. Insufficient water flow
		2. The sensor is damaged
E 33	High pressure sensor failure	1. The sensor cable is disconnected or short-circuited
		2. The sensor is damaged
		3. The motherboard port is damaged
E 34	Low pressure sensor failure	1. The sensor cable is disconnected or short-circuited
		2. The sensor is damaged
		3. The motherboard port is damaged
E 37	Inlet and outlet water temperature difference protection	1. The water inlet or outlet probe is damaged
		2. The water inlet or outlet probe is not placed in the wrong position
		3. Insufficient water flow
E 38	DC fan failure	Fan driver board or motor damaged
E 42	Cooling coil sensor failure	1. The sensor cable is disconnected or short-circuited
		2. The sensor is damaged
		3. The motherboard port is damaged
E 44	Low ambient temperature protection	normal protection
E 47	Economizer inlet sensor failure	1. The sensor cable is disconnected or short-circuited

ARDEN Heat Pumps Pty

		2. The sensor is damaged
		3. The motherboard port is damaged
E 48	Economizer inlet sensor failure	1. The sensor cable is disconnected or short-circuited
		2. The sensor is damaged
		3. The motherboard port is damaged
E 49	Economizer outlet sensor failure	Same as E47
E 51	High voltage protection	Same as E05
E 52	low voltage protection	Same as E06
E 55	Expansion board communication is abnormal	1. Poor contact or broken signal line
		2. The expansion board is damaged
		3. The motherboard is damaged
E 80	power error	The single-phase power unit detects a three-phase electrical signal
E 88	VFD module protection	The compressor or the compressor drive board is broken, please see attached table 1 for the fault
E 94	Host circulating water pump over and under pressure	1. Input power supply voltage <165V
		2. Input voltage > 265V
		3. Electronic components on the pump drive board are damaged or damp
		4. The water pump is damaged
E 96	The communication between the compressor drive and the main control board is abnormal	1. Poor contact or broken signal line
		2. Electronic components on the main control board are damaged or damp
		3. The electronic components on the drive board of the press are damaged or damp
		4. The power supply of the drive board of the press is not powered on
E 98	Abnormal communication between the fan drive and the main control board	1. Poor contact or broken signal line
		2. Electronic components on the main control board are damaged or damp
		3. The electronic components on the fan drive board are damaged or damp
		4. The power supply of the fan drive board is not powered on
E A1	Network model error	Different series of units are not allowed to network
E A2	Faulty hot water heat source sensor	1. The sensor cable is disconnected or short-circuited
		2. The sensor is damaged
		3. The motherboard port is damaged
E A3	Heating heat source sensor failure	1. The sensor cable is disconnected or short-circuited
		2. The sensor is damaged

ARDEN Heat Pumps Pty

		3. The motherboard port is damaged
E A4	Heating water tank sensor failure	1. The sensor cable is disconnected or short-circuited
		2. The sensor is damaged
		3. The motherboard port is damaged
E A5	The total water outlet sensor is faulty (multiple sets of network)	1. The sensor cable is disconnected or short-circuited
		2. The sensor is damaged
		3. The motherboard port is damaged

Table 3-12

Compressor Drive Description Schedule 1		
E88	P1	IPM overcurrent/IPM module protection
	P2	Compressor drive failure/abnormal software control/compressor out of step
	P3	compressor overcurrent
	P4	Input voltage phase loss (single phase invalid)
	P5	IPM current sampling failure
	P6	Power unit overheating shutdown
	P7	Precharge failed
	P8	DC bus overvoltage
	P9	DC bus undervoltage
	P10	AC input undervoltage
	P11	AC input overcurrent
	P12	Input voltage sampling failure
	P13	DSP and PFC communication failure
	P14	Radiator temperature sensor failure
	P15	Communication fault between DSP and communication board
	P16	Abnormal communication with the main control board
	P17	Compressor overcurrent alarm
	P18	Compressor magnetic field weakening protection alarm
	P19	IPM overheating alarm
	P20	PFC overheating alarm
	P21	AC input over-current alarm
	P22	EEPROM failure alarm
	P23	NA
	P24	EEPROM refresh is complete (can only be removed after restarting)
	P25	Temperature sensing fault frequency limiting
	P26	AC undervoltage frequency limit protection alarm

ARDEN Heat Pumps Pty

P27	NA
P28	NA
P29	NA
P30	NA
P31	NA
P32	NA
P33	IPM Module Thermal Shutdown
P34	Compressor phase loss
P35	compressor overload
P36	Input Current Sampling Fault
P37	IPM supply voltage failure
P38	Precharge Circuit Voltage Failure
P39	EEPROM failure
P40	AC input overvoltage fault
P41	microelectronic failure
P42	Compressor code failure
P43	Current sampling signal overcurrent (hardware overcurrent)
The wire controller flashes and displays codes E88 and above in a cycle	

Table 3-13

3.7. Waterway installation and wiring

3.7.1. Comparison of system legends

Legend code comparison table

Code	assembly unit	Code	assembly unit
0	Heat pump host	DC3	Auxiliary heat source water pump P_e linkage switch on the heating side
1	Vent	DC4	Auxiliary heat source water pump P_f linkage switch on the hot water side
2	Flow switch	T15	Outlet water temperature T15 sensor
3	pressure relief valve	T16	Hot water tank temperature sensor
4	Expansion tank	T10	Buffer water tank temperature sensor (optional)
5	Globe valve (personal purchase)	T9	Total outlet water temperature T15 sensor (optional)
6	Filters (individual purchases)	T11	Heating side heat source temperature sensor (optional)
7	One-way valve (personal purchase)	T12	Hot water side heat source temperature sensor (optional)
8	Bypass valve (personal purchase)	P_a	Host circulation pump (PWM)
9	buffer tank	P_b	Heating secondary circulation pump (personal purchase)
10	Domestic hot water tank	P_c	Auxiliary pump (personal purchase)
EH1	Hot water tank electric	P_d	User return pump (personal purchase)

ARDEN Heat Pumps Pty

	heating/gas control signal		
EH2	Heating water tank electric heating (personal purchase)	P_e	Auxiliary heat source pump on the hot water side (personal purchase)
SV1	Hot water electric three-way valve (personal purchase)	P_f	Auxiliary heat source pump on the heating side (personal purchase)
SV2	Air conditioner electric three-way valve (personal purchase)	P_g	Gas circulation pump (personal purchase)
T8	Inlet water temperature sensor	KA1-KA4	Intermediate relay (personal purchase)
AHS	Additional heat source (wall-hung boiler) (personal purchase)	KM1-KM4	AC contactor (personal purchase)
DC1	Unit linkage switch		
DC2	Heating secondary water pump P_b linkage switch		

Note: The installation diagram examples in this chapter are all described in the above table

3.7.2. Single floor heating mode water system installation diagram

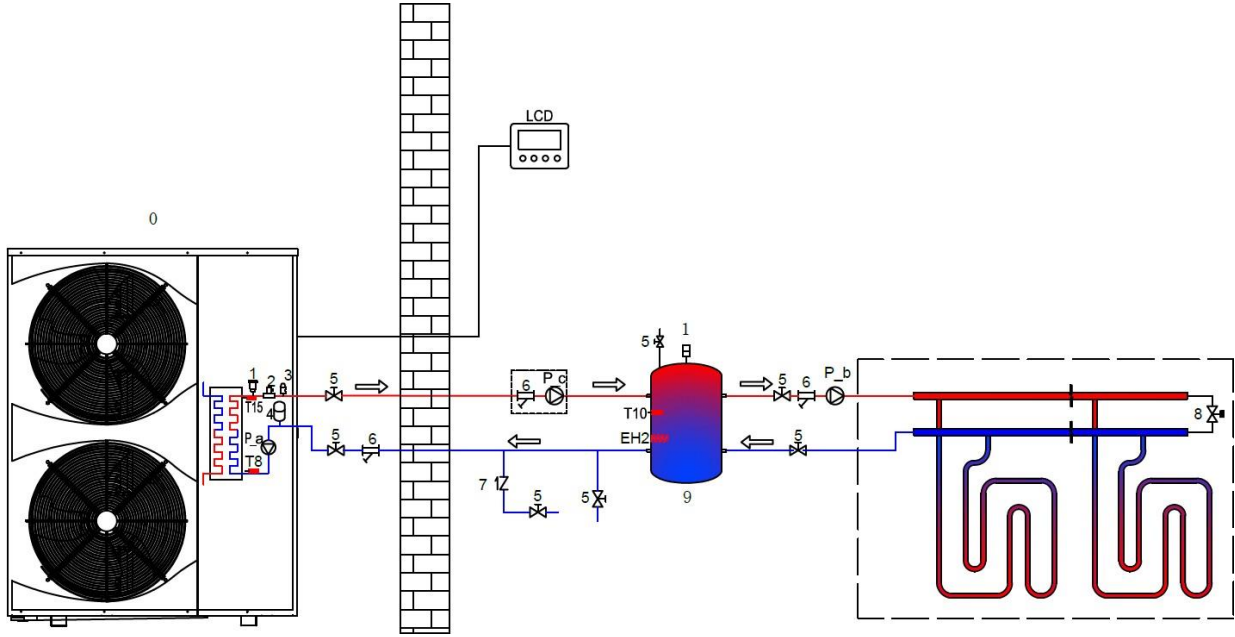

3.7.3. Heating or cooling mode water system installation diagram

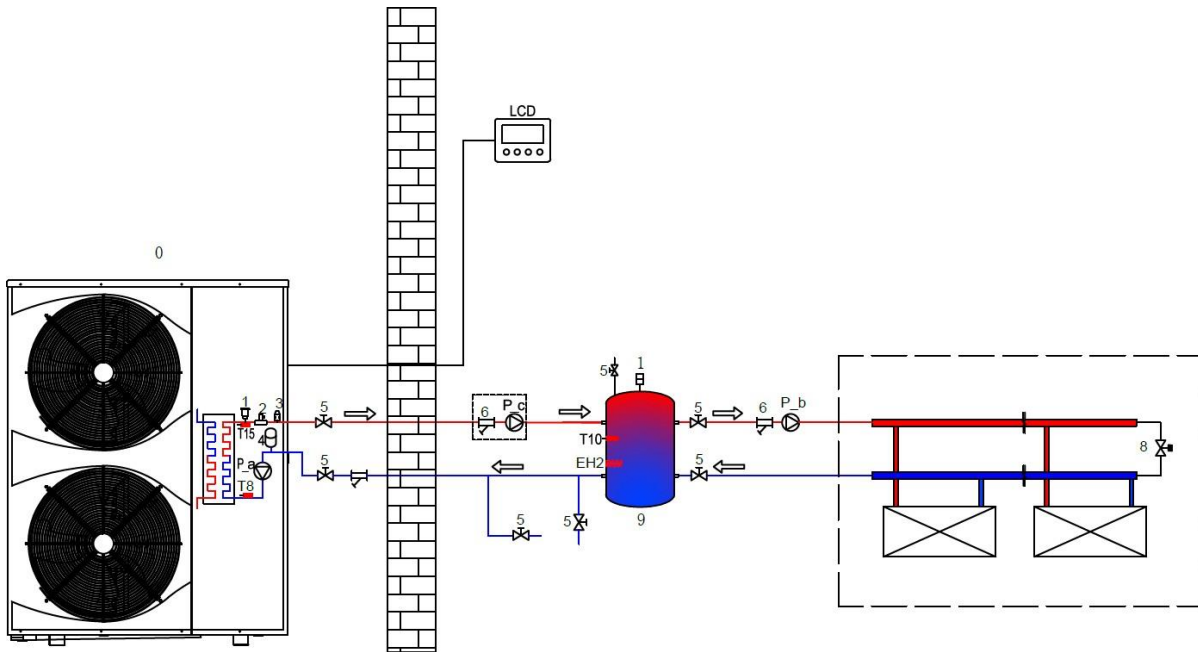

When the application scenario is underfloor heating, heating, and cooling mode, it is necessary to set parameters P48=0 (disable the water tank temperature sensor), L12=1 (disable high-temperature sterilization).

3.7.4. Schematic diagram of wiring in floor heating, heating, and cooling modes

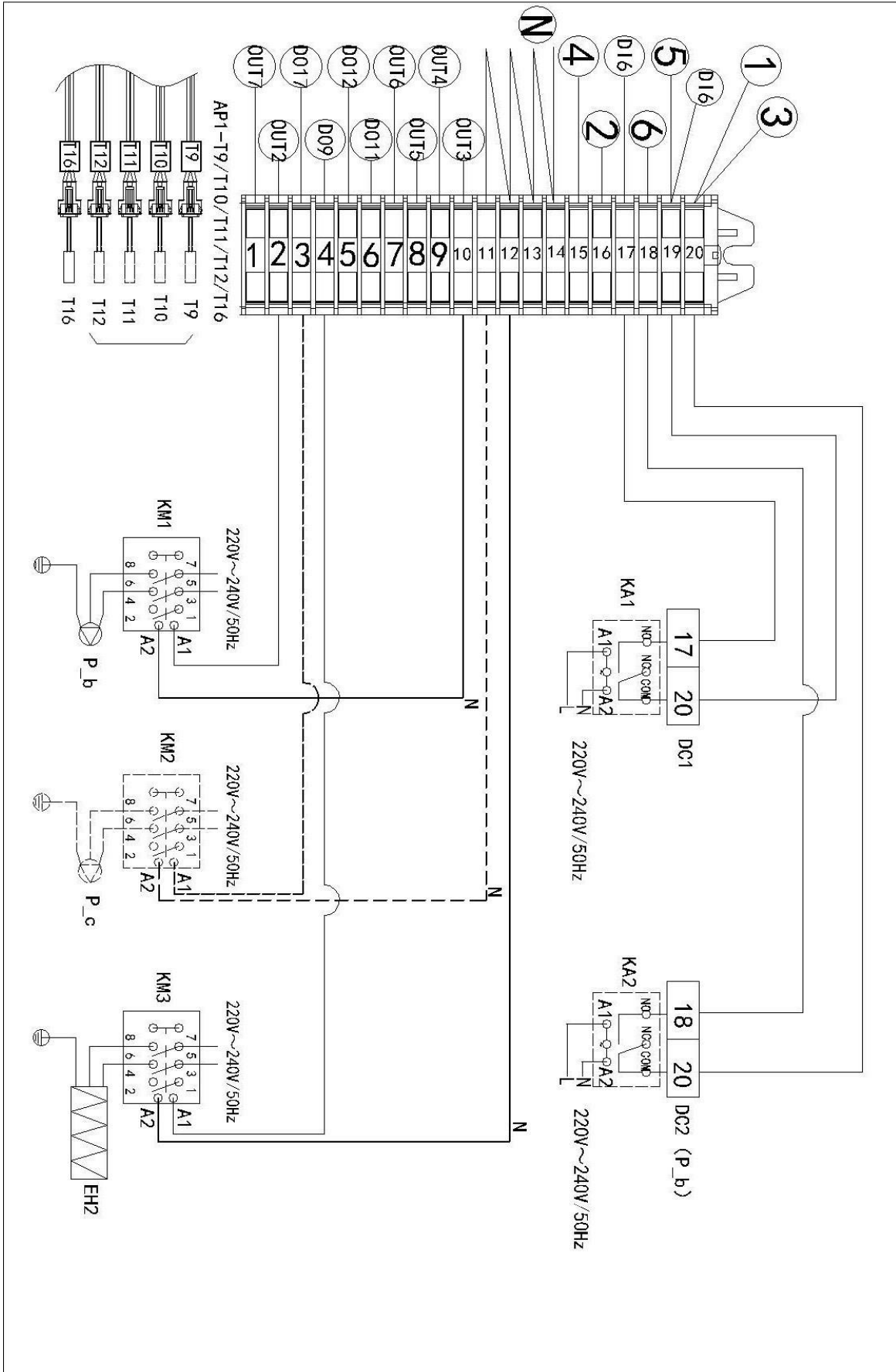

3.7.5. Hot water + cooling or hot water + heating mode water system installation diagram

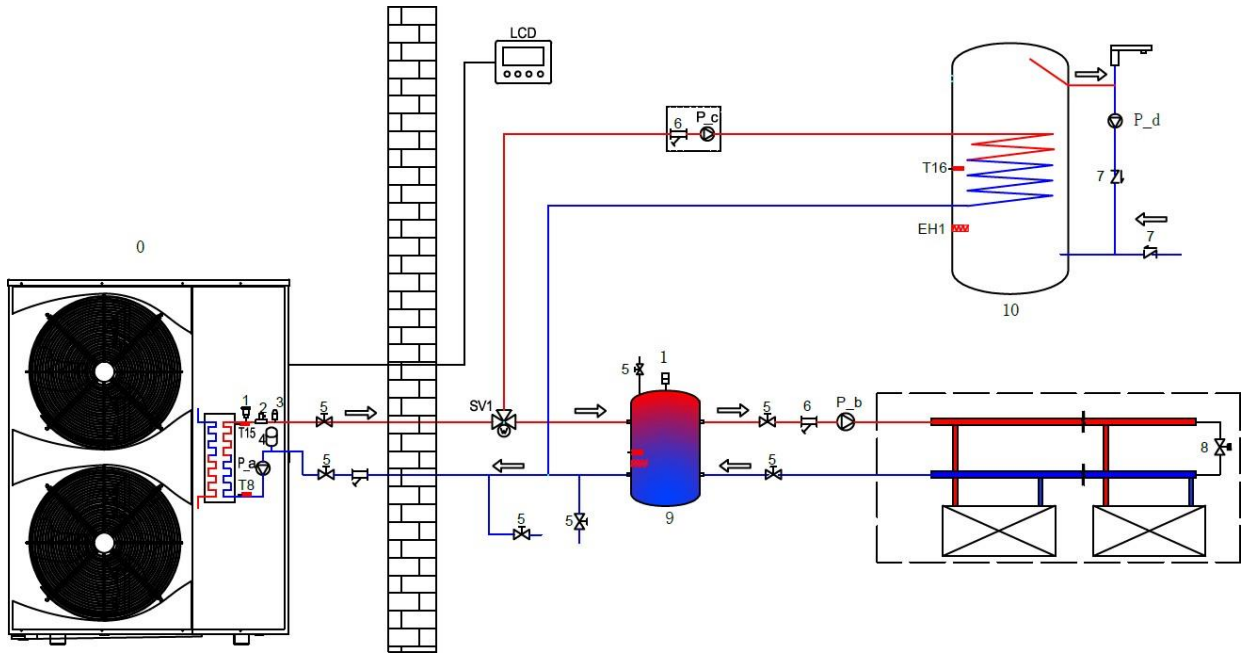

3.7.6. Hot water + floor heating mode water system installation diagram

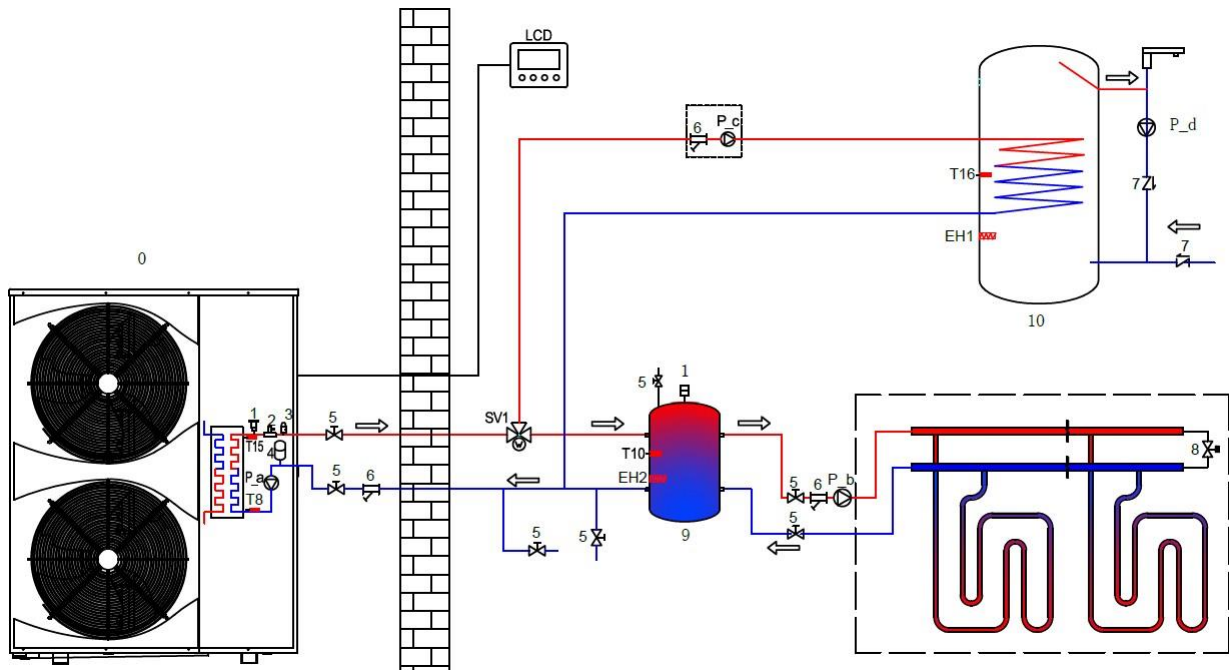

(1) When the lift of the DC water pump of the unit P_a pump is not enough, the auxiliary water pump P_c needs to be connected externally, and the parameter P161 needs to be set to 0 .

(2) When the parameter P150=2, the P_b water pump starts and stops according to the linkage switch of the heating secondary pump. When the parameter P150=3, the P_b water pump starts and stops according to the indoor temperature.

3.7.7. Water wiring diagram for hot water + cooling, hot water + heating, hot water + floor heating modes

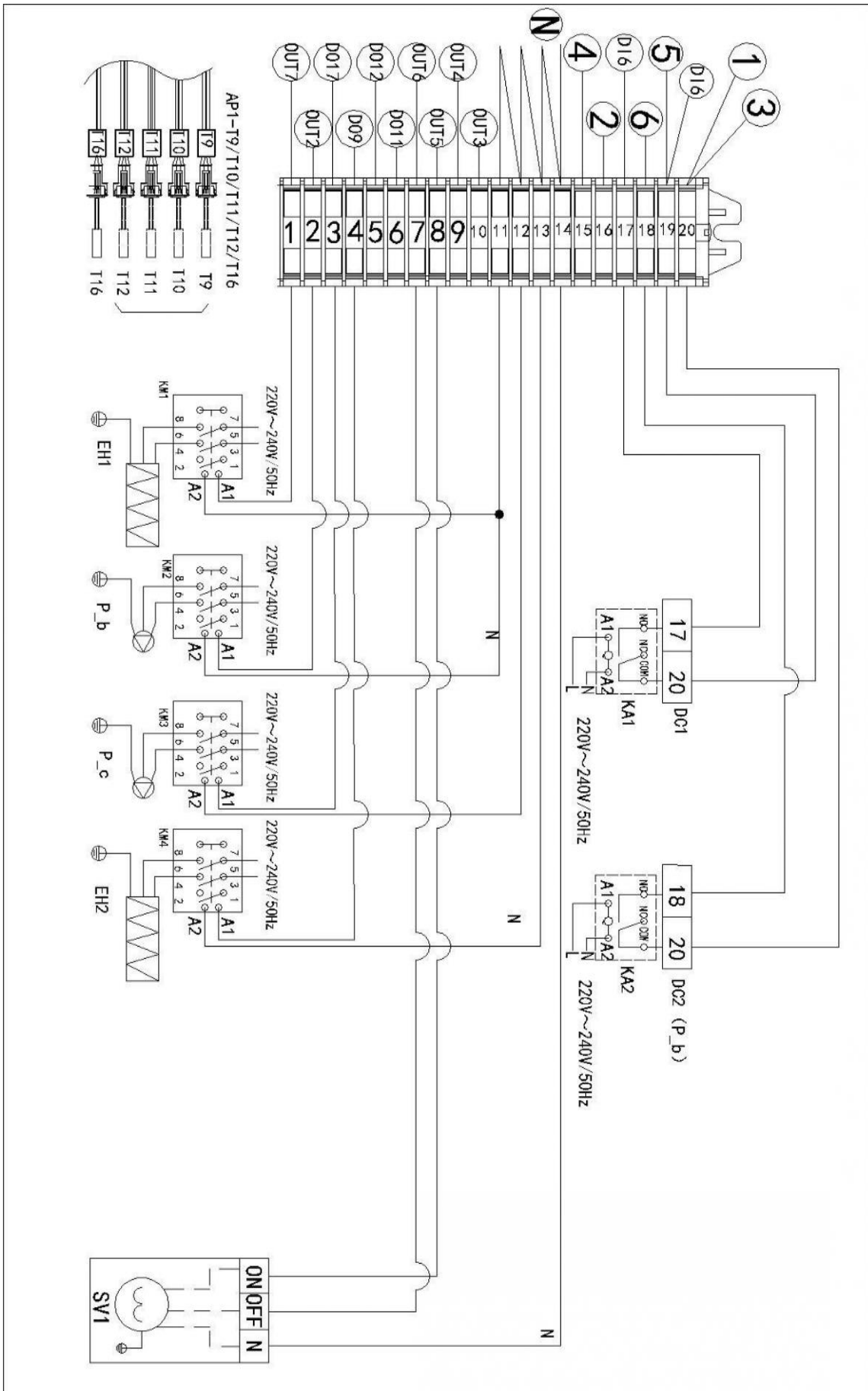

3.7.9. Wiring diagram in hybrid mode

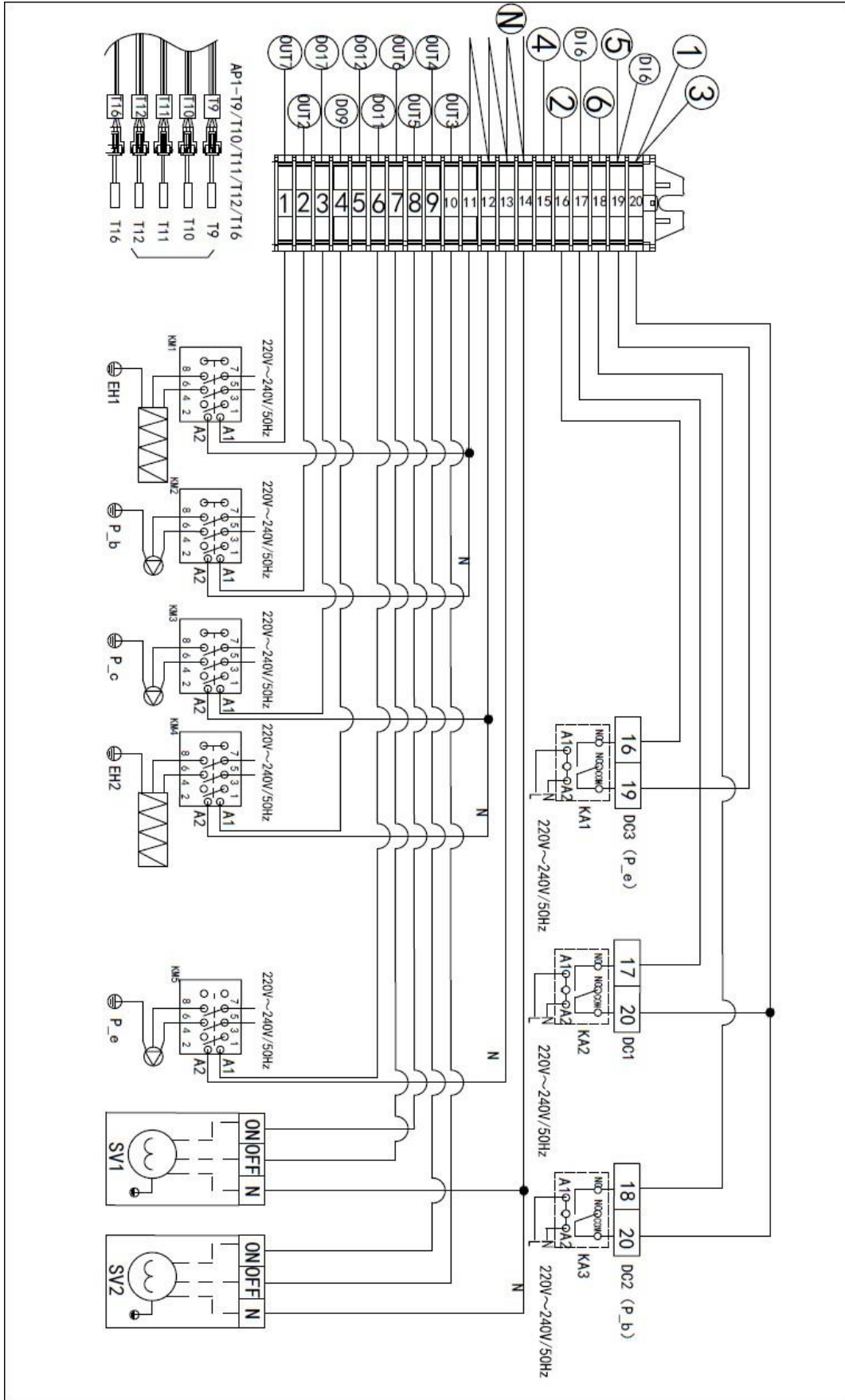

3.7.10. Cascade mode waterway installation schematic

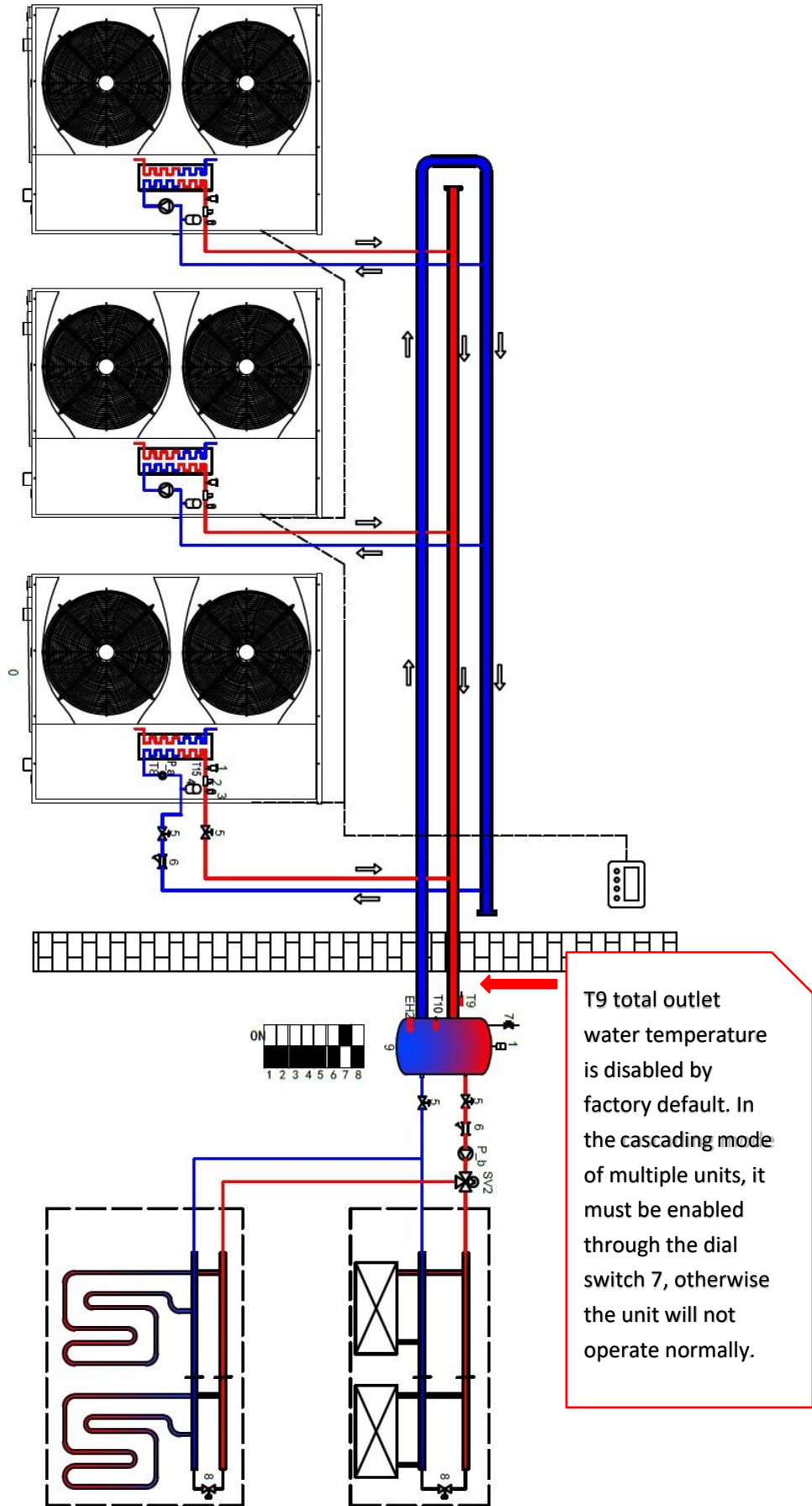

3.7.11. Cascading mode water circuit wiring diagram

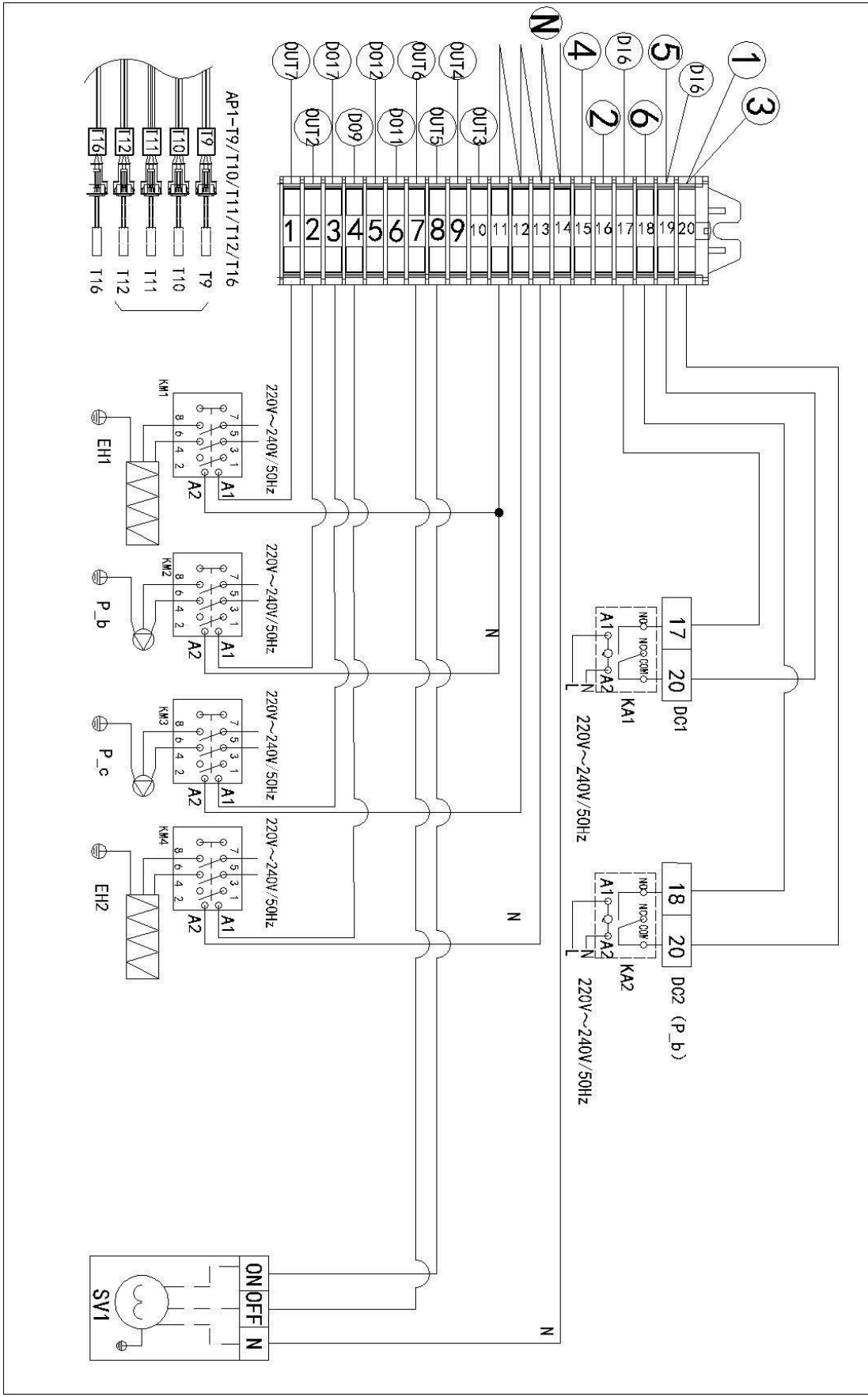

3.7.12. Floor heating + refrigeration + hot water + gas waterway installation schematic

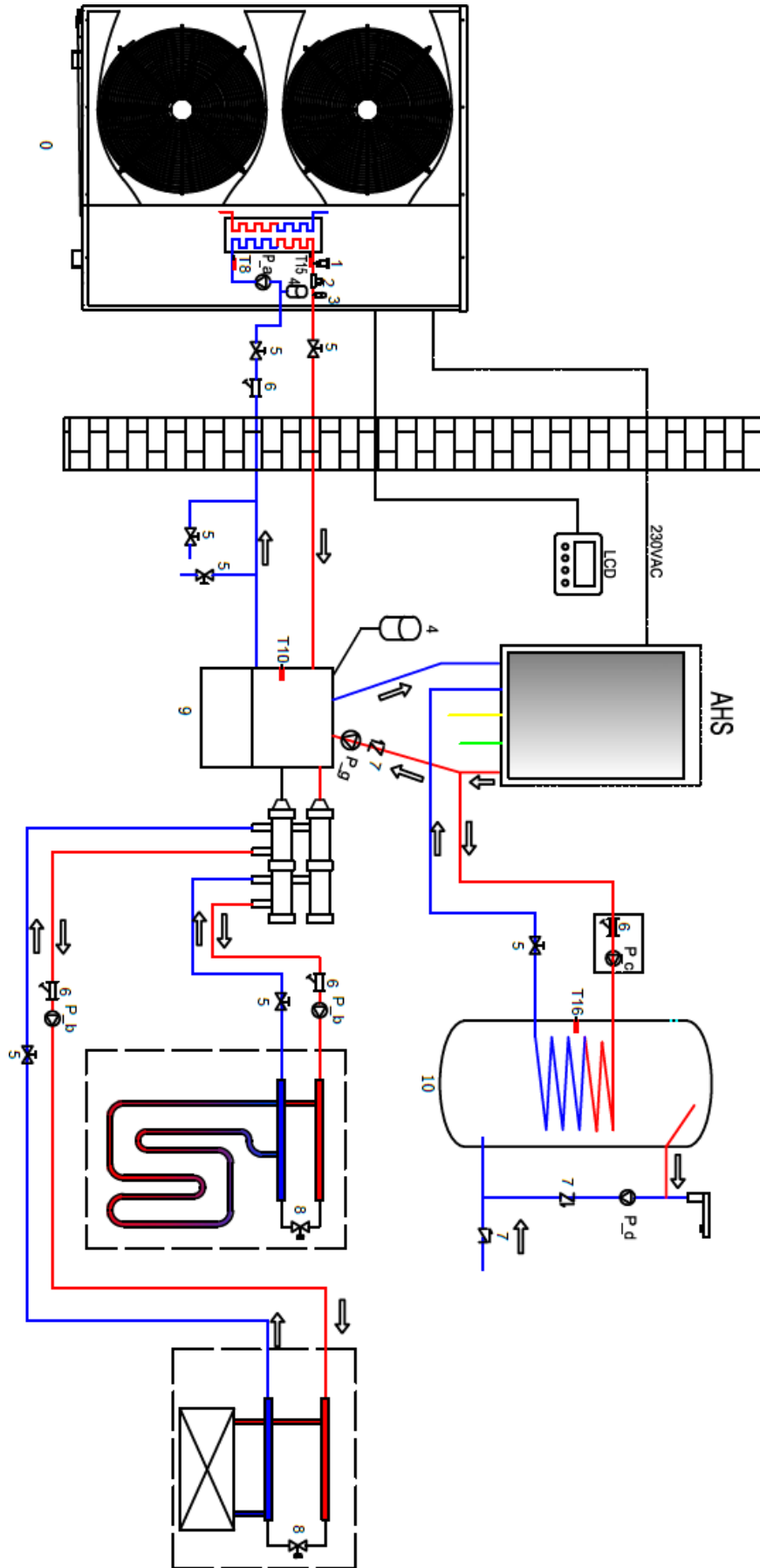

3.7.13. Floor heating + refrigeration + hot water + gas water circuit wiring diagram

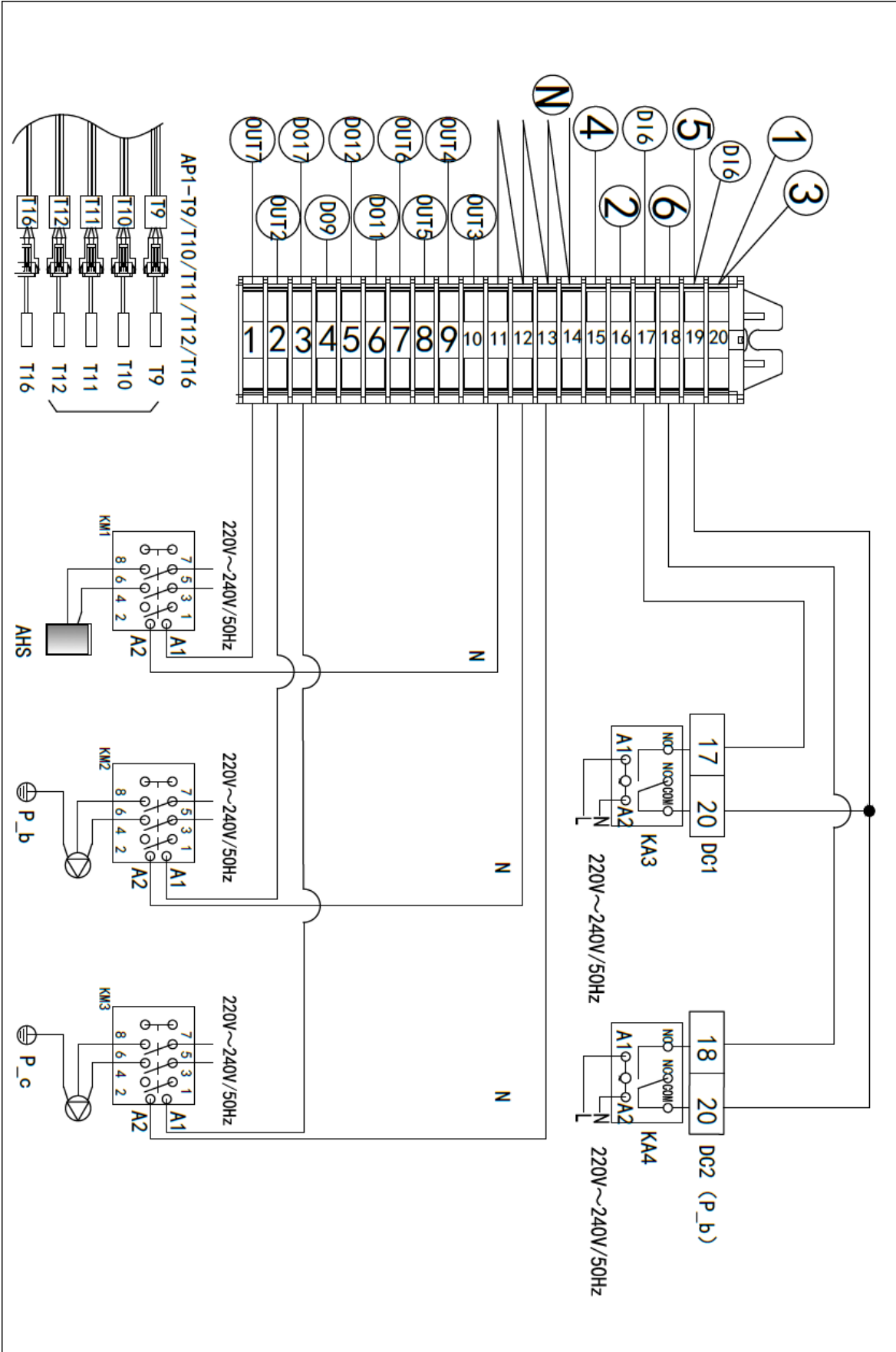

3.7.14. Three-way valve wiring method

(1) Three-wire one-control three-way valve wiring method:

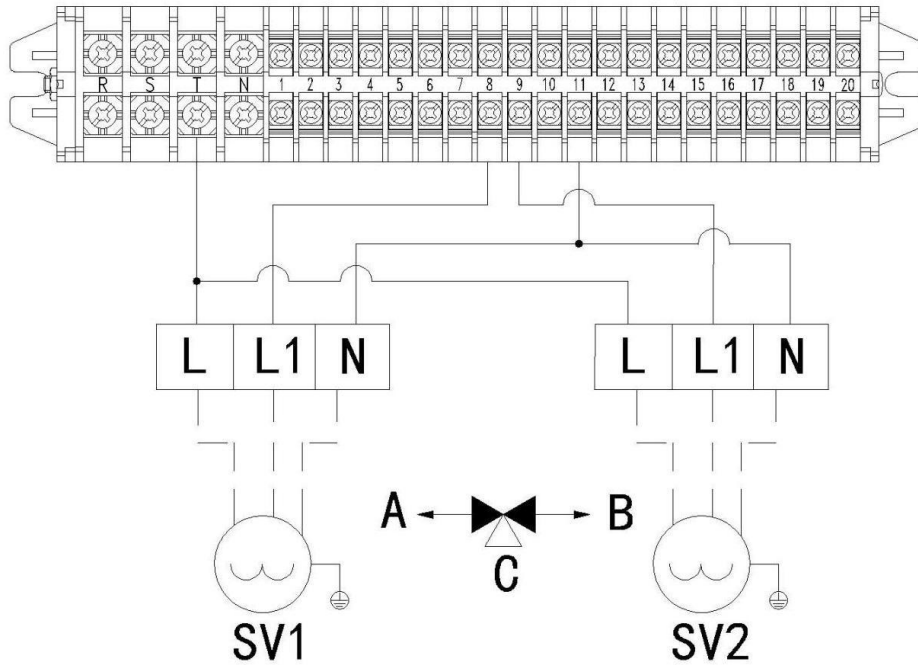

According to the above figure, C is the input terminal, and the output terminals are A and B. When the voltage (VAC230V) is only applied to the L line, the valve maintains the initial position C-B, that is, the flow drops from C to B position. When the voltage is applied to the L1 line, the valve drops to the C-A position, that is, the flow drops from C to A position. When the voltage on the L1 line is removed, the valve drops back to the C-B position.

(2) Wiring mode of three-wire two-control three-way valve:

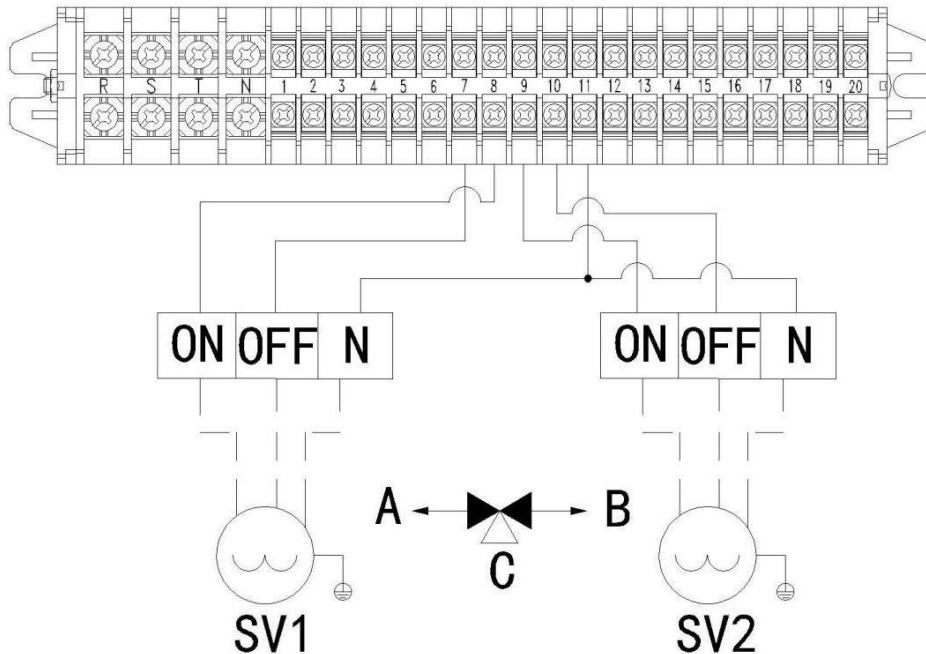

According to the above figure, C is the input terminal, and the output terminals are A and B. When the voltage (VAC230V) is applied to the ON line, the valve maintains the initial position C-B, that is, the flow drops from C to B position. When the voltage is applied to the OFF line, the valve drops to the C-A position, that is, the flow drops from C to A position.

3.9. NCT Sensor Resistance Table

5K Sensor Resistance Table													
temperature (°C)	Resistance (KΩ)	temperature (°C)	Resistance (KΩ)	temperature (°C)	Resistance (KΩ)	temperature (°C)	Resistance (KΩ)	temperature (°C)	Resistance (KΩ)	temperature (°C)	Resistance (KΩ)	temperature (°C)	Resistance (KΩ)
-40	108.4	-13	26.2913	14	7.7643	41	2.7692	68	1.1413	95	0.5196	122	0.2677
-39	102.3	-12	25.033	15	7.4506	42	2.6735	69	1.1008	96	0.5088	123	0.2615
-38	96.62	-11	23.8424	16	7.1813	43	2.5816	70	1.0734	97	0.4919	124	0.2554
-37	91.26	-10	22.7155	17	6.8658	44	2.4936	71	1.0412	98	0.4786	125	0.2496
-36	86.23	-9	21.6486	18	6.5934	45	2.4097	72	1.01	99	0.465	126	0.2438
-35	81.51	-8	20.638	19	6.3333	46	2.3276	73	0.98	100	0.4533	127	0.2383
-34	77.08	-7	19.6806	20	6.085	47	2.2491	74	0.9508	101	0.4418	128	0.2329
-33	72.92	-6	18.7732	21	5.8479	48	2.1739	75	0.9228	102	0.4385	129	0.2276
-32	69.01	-5	17.9129	22	5.6213	49	2.1016	76	0.8957	103	0.4273	130	0.2225
-31	65.33	-4	17.097	23	5.4048	50	2.0321	77	0.8695	104	0.4165	131	0.2175
-30	63.7306	-3	16.323	24	5.1978	51	1.9656	78	0.8441	105	0.406	132	0.2127
-29	60.3223	-2	15.5886	25	5	52	1.9016	79	0.8196	106	0.3958	133	0.2079
-28	57.118	-1	14.8713	26	4.8108	53	1.8399	80	0.7959	107	0.3859	134	0.2034
-27	54.1043	0	14.2293	27	4.6298	54	1.7804	81	0.773	108	0.3763	135	0.1989
-26	51.2686	1	13.6017	28	4.4586	55	1.7232	82	0.7508	109	0.367		
-25	48.5994	2	13.0057	29	4.2909	56	1.668	83	0.7295	110	0.3579		
-24	46.086	3	12.439	30	4.1323	57	1.614	84	0.7086	111	0.3491		
-23	43.7182	4	11.9011	31	3.9804	58	1.5636	85	0.6885	112	0.3406		
-22	41.4868	5	11.3894	32	3.8349	59	1.5142	86	0.669	113	0.3323		
-21	39.3833	6	10.9028	33	3.6955	60	1.4856	87	0.6502	114	0.3243		
-20	37.3992	7	10.4399	34	3.562	61	1.4206	88	0.632	115	0.3165		
-19	35.5274	8	9.9995	35	3.434	62	1.3763	89	0.6144	116	0.3089		
-18	33.7607	9	9.5802	36	3.3119	63	1.3336	90	0.5973	117	0.3015		
-17	32.0927	10	9.181	37	3.1937	64	1.2923	91	0.5808	118	0.2944		
-16	30.5172	11	8.8008	38	3.0809	65	1.2526	92	0.5647	119	0.2874		
-15	29.0286	12	8.4395	39	2.9727	66	1.2142	93	0.5492	120	0.2807		
-14	27.6216	13	8.0934	40	2.8688	67	1.1771	94	0.5342	121	0.2741		







ARDEN Heat Pumps Pty

50K Sensor Resistance Table

temperature (°C)	Resistance (kΩ)	temperature (°C)	Resistance (kΩ)	temperature (°C)	Resistance (kΩ)	temperature (°C)	Resistance (kΩ)	temperature (°C)	Resistance (kΩ)	temperature (°C)	Resistance (kΩ)	temperature (°C)	Resistance (kΩ)
-40	1588	-12	306.29	16	75.001	44	22.648	72	8.0903	100	3.312	128	1.5165
-39	1489	-11	290.06	17	71.625	45	21.773	73	7.8193	101	3.215	129	1.4774
-38	1396	-10	274.78	18	68.416	46	20.935	74	7.5586	102	3.1214	130	1.4396
-37	1310	-9	260.4	19	65.368	47	20.134	75	7.3077	103	3.031	131	1.4028
-36	1230	-8	246.85	20	62.474	48	19.368	76	7.0667	104	2.9435	132	1.3672
-35	1156	-7	234.08	21	59.719	49	18.635	77	6.8345	105	2.8589	133	1.3327
-34	1086	-6	222.02	22	57.104	50	17.932	78	6.6109	106	2.7772	134	1.2991
-33	1021	-5	210.69	23	54.62	51	17.26	79	6.396	107	2.6982	135	1.2665
-32	959.9	-4	199.98	24	52.253	52	16.616	80	6.189	108	2.6218	136	1.2349
-31	903.1	-3	189.86	25	50	53	16.001	81	5.9894	109	2.5479	137	1.2042
-30	866.96	-2	180.34	26	47.857	54	15.41	82	5.7976	110	2.4764	138	1.1744
-29	815.7	-1	171.33	27	45.817	55	14.844	83	5.6126	111	2.4072	139	1.1455
-28	767.71	0	162.81	28	43.877	56	14.302	84	5.4346	112	2.3403	140	1.1174
-27	722.87	1	154.78	29	42.027	57	13.782	85	5.2629	113	2.2755	141	1.0901
-26	680.87	2	147.19	30	40.265	58	13.284	86	5.0974	114	2.2128	142	1.0636
-25	641.59	3	140	31	38.585	59	12.807	87	4.9379	115	2.1522	143	1.0379
-24	604.82	4	133.21	32	36.987	60	12.348	88	4.7842	116	2.0934	144	1.0128
-23	570.34	5	126.79	33	35.462	61	11.909	89	4.6359	117	2.0365	145	0.9886
-22	538.03	6	120.72	34	34.007	62	11.487	90	4.4931	118	1.9814	146	0.9649
-21	507.74	7	114.96	35	32.619	63	11.083	91	4.3552	119	1.928	147	0.942
-20	479.34	8	109.51	36	31.297	64	10.694	92	4.2222	120	1.8764	148	0.9197
-19	452.68	9	104.34	37	30.034	65	10.321	93	4.0939	121	1.8263	149	0.898
-18	427.67	10	99.456	38	28.827	66	9.9628	94	3.97	122	1.7778	150	0.8769
-17	404.17	11	94.826	39	27.677	67	9.6187	95	3.8506	123	1.7308		
-16	382.11	12	90.426	40	26.578	68	9.2882	96	3.7351	124	1.6852		
-15	361.35	13	86.262	41	25.528	69	8.9706	97	3.6238	125	1.6411		
-14	341.86	14	82.312	42	24.524	70	8.6655	98	3.5162	126	1.5983		
-13	323.53	15	78.561	43	23.566	71	8.3723	99	3.4123	127	1.5567		

4. Error Diagnosis and Treatment

4.1. maintenance tools



NO.	tool name	Picture	Function
1	Phillips screwdriver (6 inches)		Remove Phillips screws
2	Slotted screwdriver (6 inches)		Remove the flat screw
3	Adjustable wrench (6 inches)		Screw removal, etc.
4	Needle nose pliers (6 inches)		Cut wires, remove terminals, etc.
5	Hex wrench (No. 5)		open stop valve etc.
6	electric screw driver		Remove screws etc.

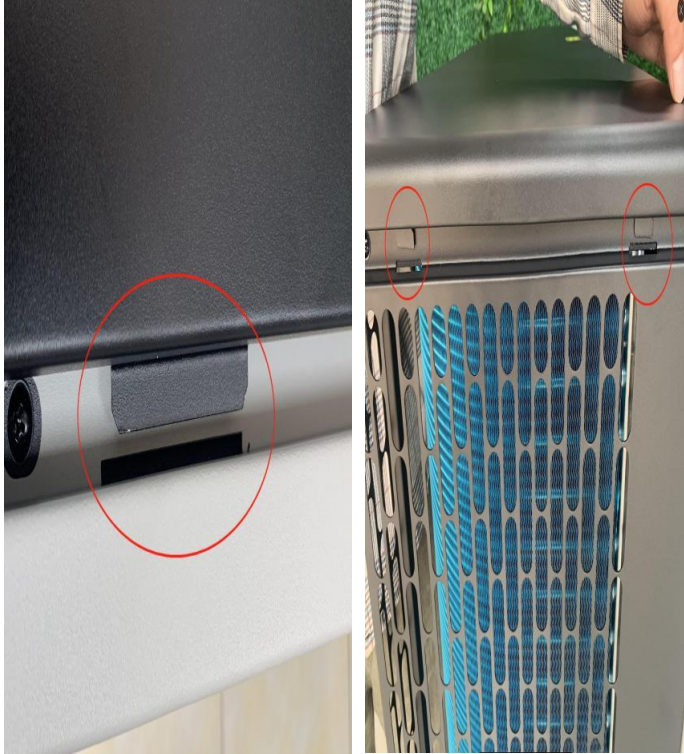

<p>7</p>	<p>clamp multimeter</p>		<p>Measure current, voltage, resistance, capacitance, etc.</p>
<p>8</p>	<p>vacuum pump</p>		<p>Fluorine system vacuuming</p>
<p>9</p>	<p>Double head pressure gauge</p>		<p>Measurement of fluorine system pressure, vacuuming, etc.</p>

Note: Other special tools are not listed, and the above tools can guarantee basic maintenance and testing.

4.2. Model disassembly and parts



NO.	Picture	steps
1		<p>How to remove the roof trim: Step 1: Unscrew the 2 screws on the front panel with a "+" screwdriver or electric cross tool.</p>
2		<p>Step 2: Pay attention to the buckle when taking off the top decorative board.</p>

<p>3</p>		<p>How to open the top cover: Step 3: After the fixing screws are removed, to take off the top cover, you need to pull back at the two screw holes, and pull up 45° at the same time.</p>
<p>4</p>		<p>Front trim panel removal: Step 1: After the top cover is removed, you only need to remove the 7 screws on the bottom front and the top to remove the front trim panel, and you can use a "+"-shaped screwdriver or an electric cross tool.</p>

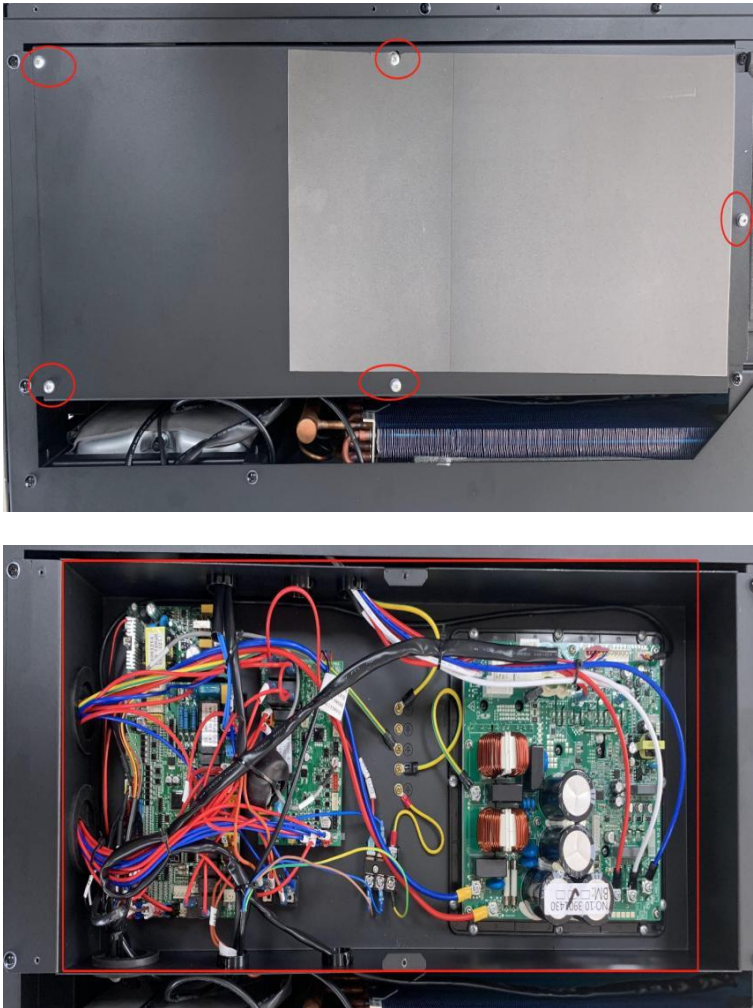

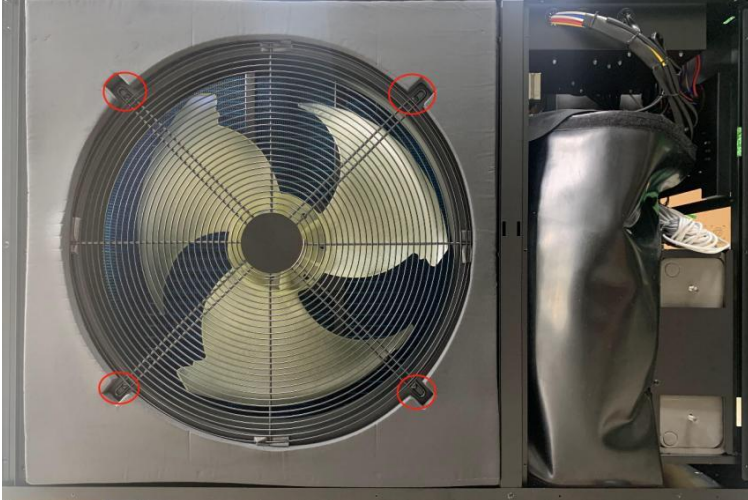
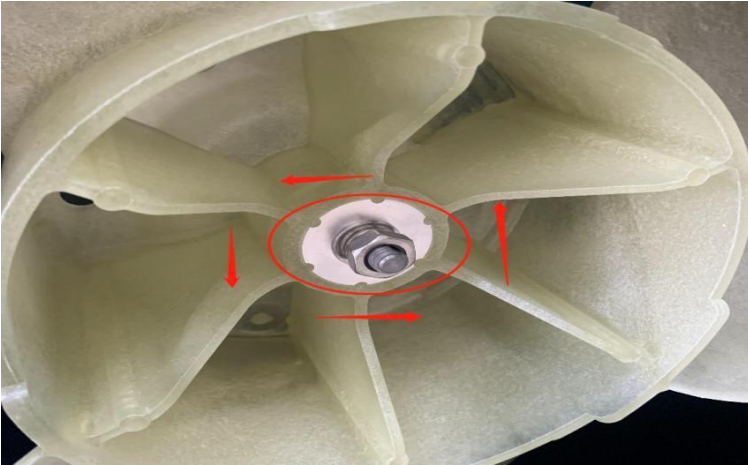
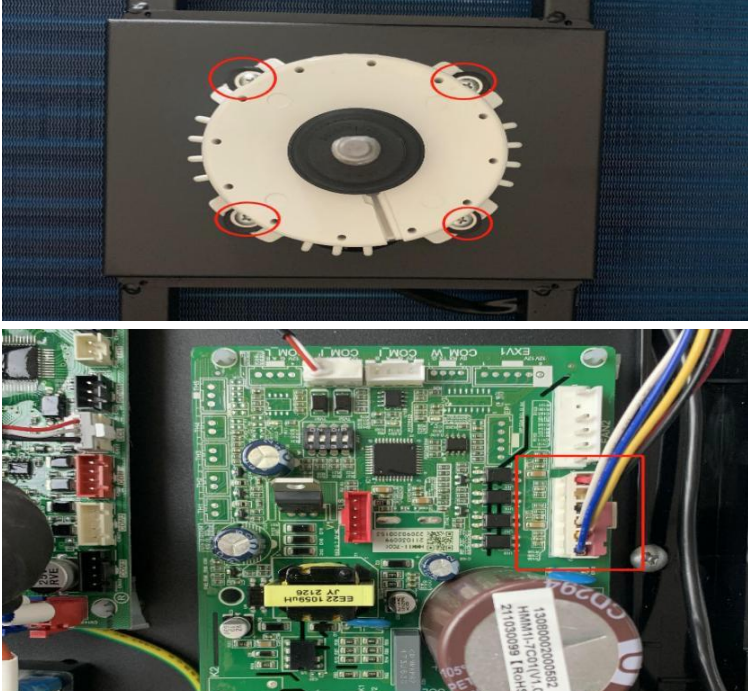
5		<p>Remove the front trim panel: Step 2: After the screws are removed, pull up with both hands to remove the front trim panel. (Note: There are buckles on the left and right sides of the front trim panel).</p>
6		<p>Removal of the right decorative panel: Remove the two screws at the bottom of the decorative plate, push down with both hands to take off the decorative plate, (note the buckle).</p>

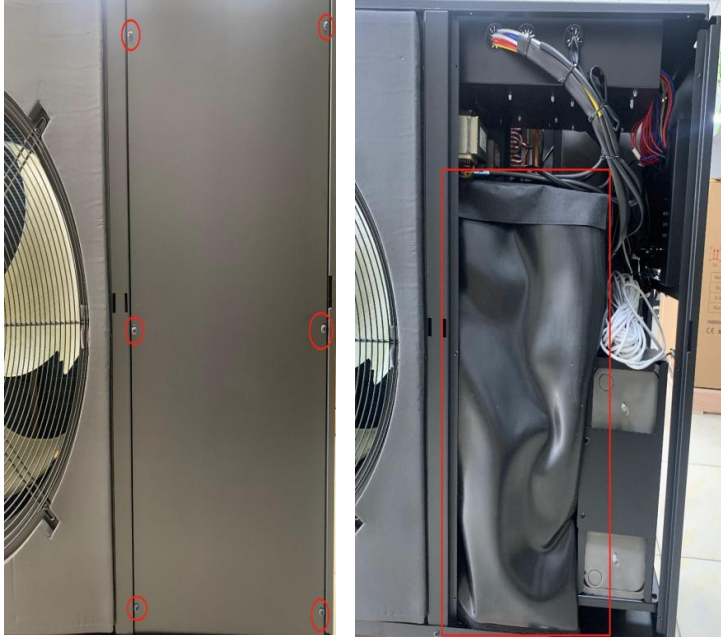

<p>7</p>		<p>Removal of the decoration plate of the user terminal: Use a "+"-shaped screwdriver or an electric cross tool to remove the four fixing screws.</p>
<p>8</p>		<p>Electric control: Use a "+"-shaped screwdriver or electric cross tool to remove the 4 fixing screws.</p>

9		<p>Fan removal: Step 1: Use a "+"-shaped screwdriver or an electric cross tool to unscrew the 4 screws of the decorative version.</p>
10		<p>Step 2: Use an adjustable wrench to remove the fan blade (counterclockwise) and remove the fan blade.</p>
11		<p>Step 3: Remove the 4 screws fixing the fan.</p> <p>Step 4: After the fixing screws are removed, find the connecting wire connected to the fan on the drive board on the top of the machine and unplug it to complete the removal of the fan.</p> <p>(FAN1)</p>

<p>12</p>		<p>Compressor removal:</p> <p>Step 1: Use a "+"-shaped screwdriver or an electric cross tool to unscrew the 6 screws on the decorative panel.</p> <p>Step 2: Remove the compressor mute sponge.</p>
<p>13</p>		<p>Step 3: Use adjustable wrench and needle-nose pliers to remove the power cable connected to the compressor.</p>

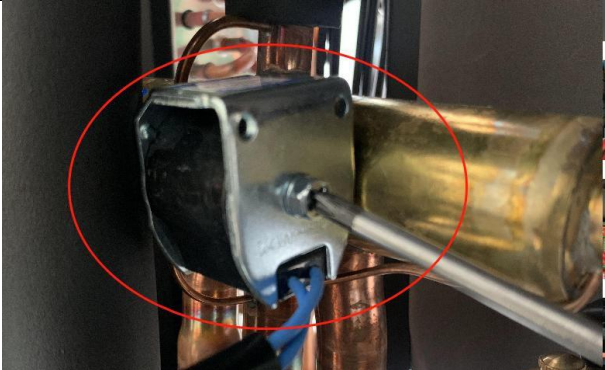
<p>14</p>		<p>Step 4: Drain the refrigerant. Use adjustable wrench, hexagonal wrench, and pressure gauge connected to the low-pressure refrigerant inspection port to open the valve to discharge the refrigerant. (Note: The refrigerant must be discharged cleanly before welding can be performed.)</p>
<p>15</p>		<p>Step 5: Make sure the refrigerant is discharged cleanly. Use a torch to heat the compressor exhaust, and go back to the copper pipe to remove it. (Beware of high temperature burns, keep away from combustibles.)</p>

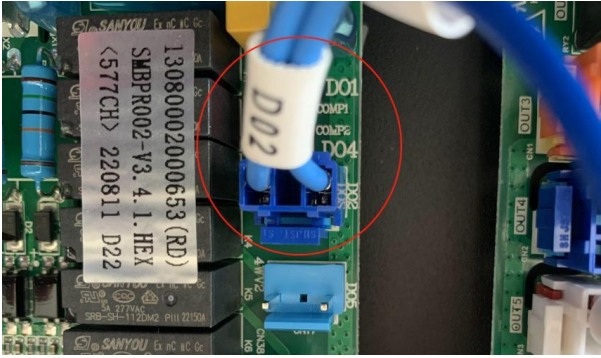
16	 	<p>Step 6: Use needle-nose pliers to remove the crankshaft heating belt.</p> <p>Step 7: Use an adjustable wrench to remove the three nuts that fix the compressor.</p>
17		<p>Four-way valve removal:</p> <p>Step 1: Remove the fixing screws.</p> <p>Step 2: Remove the main control board connection wire (D02).</p>

		
18		<p>Rear trim panel removal: Use a "+"-shaped screwdriver or an electric cross tool to unscrew the 11 screws on the decorative panel.</p>

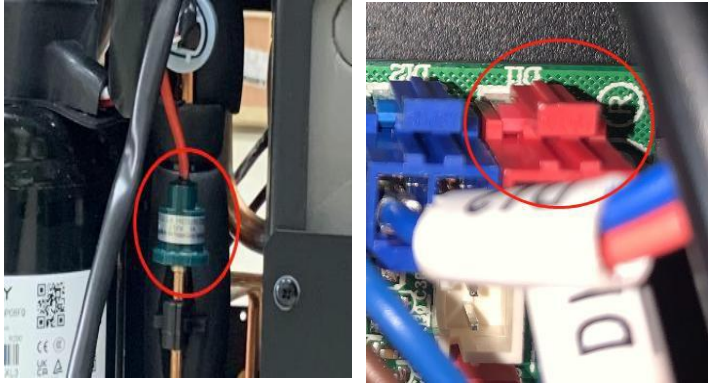
19		Main circuit electronic expansion valve
20		High voltage switch DI1

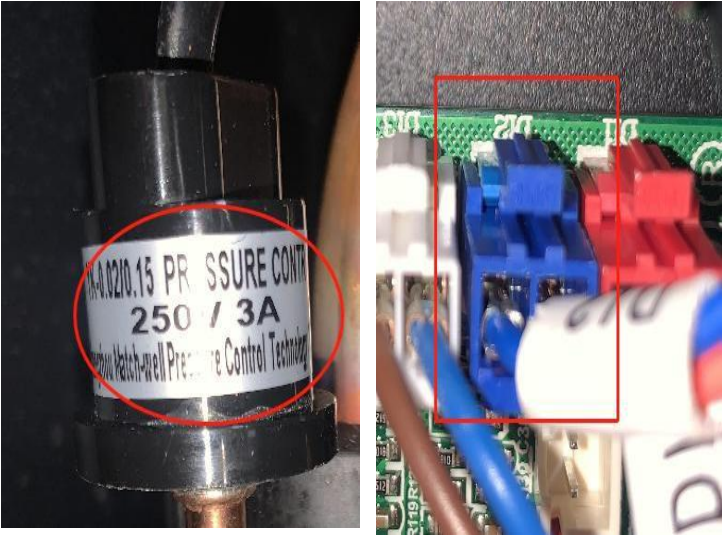
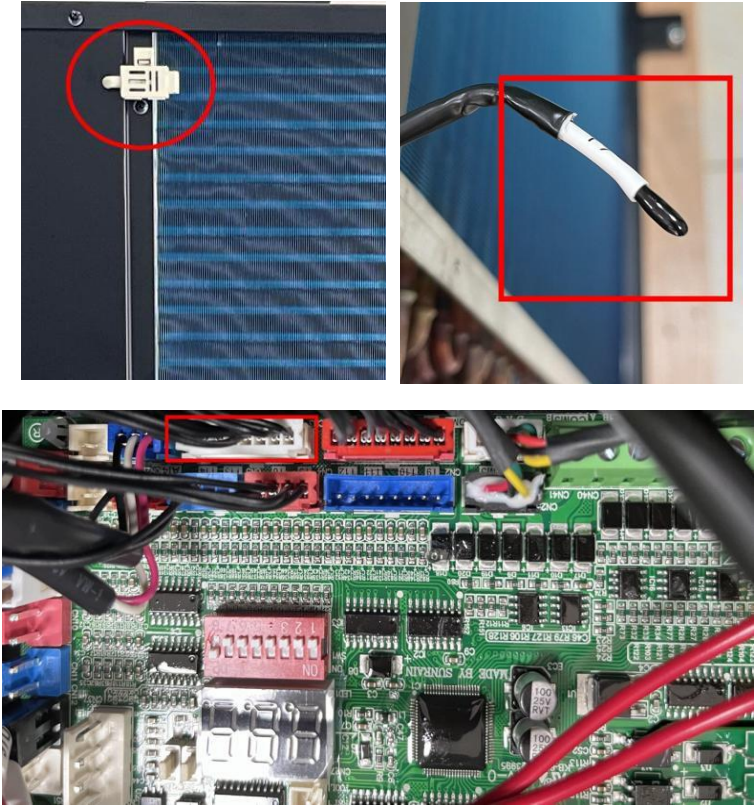
<p>21</p>		<p>Low voltage switch DI2</p>
<p>22</p>		<p>Ambient temperature sensor T7 (5K)</p>

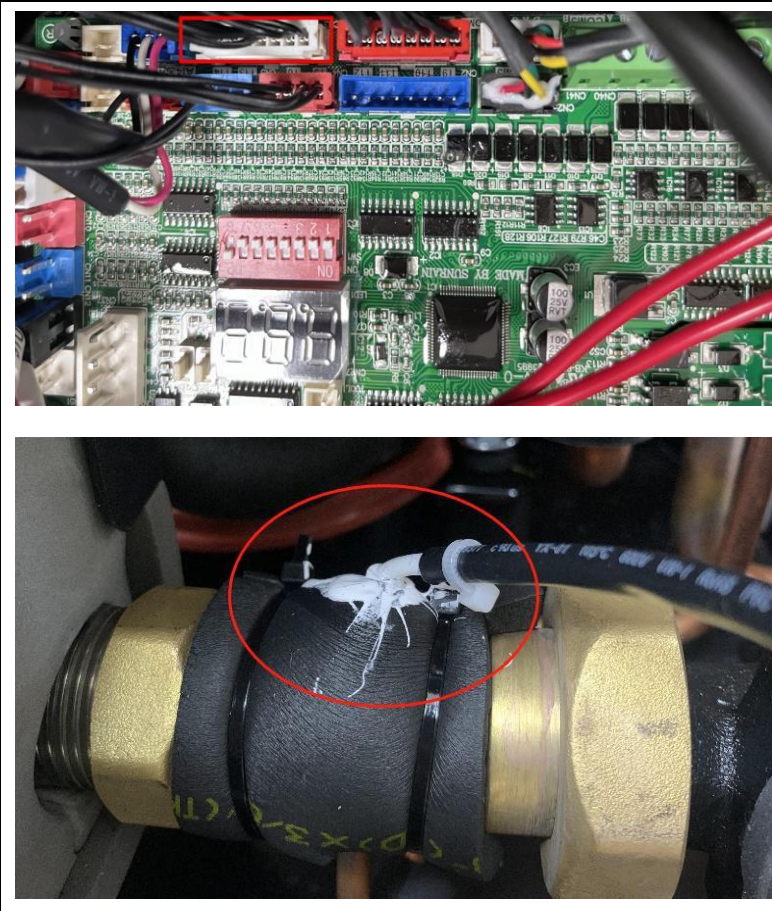
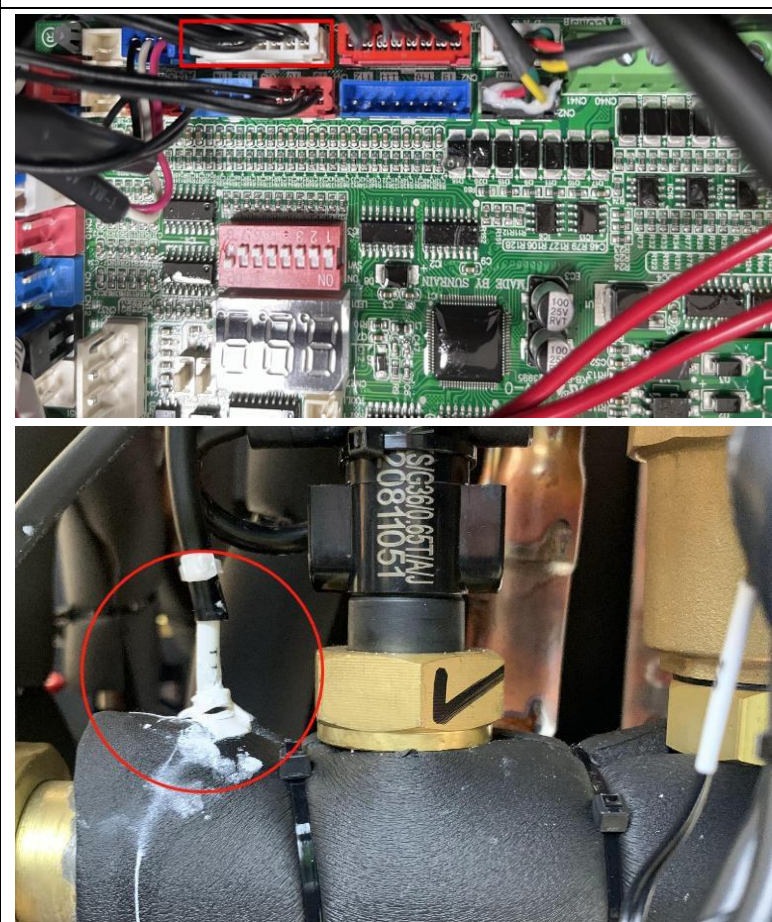
<p>23</p>		<p>Inlet water temperature sensor T8 (5K)</p>
<p>24</p>		<p>Outlet water temperature sensor T15 (5K)</p>

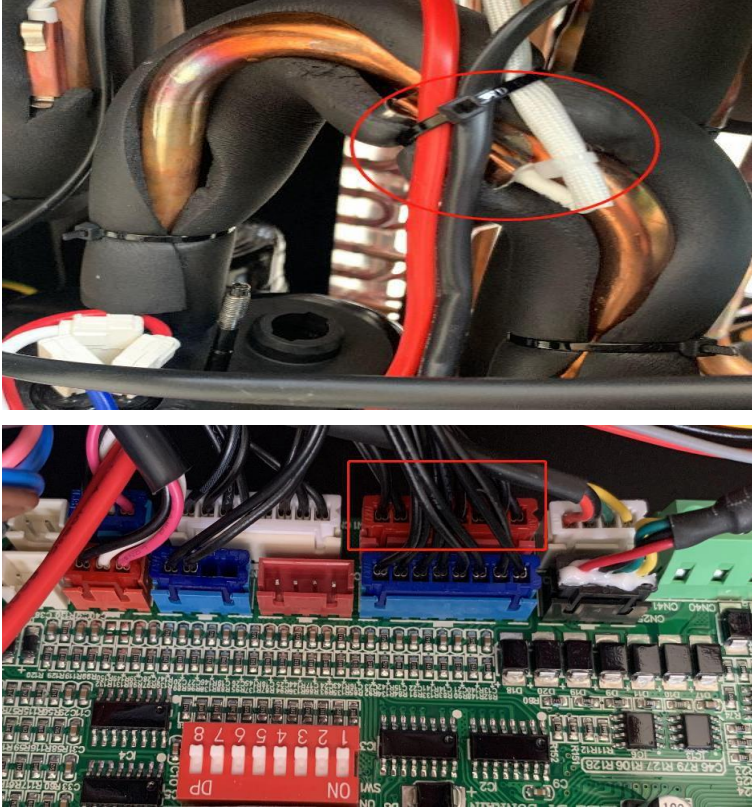
<p>25</p>		<p>T9 total outlet water temperature T155K</p> <p>T10 heating water tank temperature 5K</p> <p>T11 heating measuring heat source temperature 5K</p> <p>T12 hot water side heat source temperature 5K</p> <p>T16 hot water tank temperature 5K</p>
<p>26</p>		<p>T3 exhaust temperature sensor 50K</p>

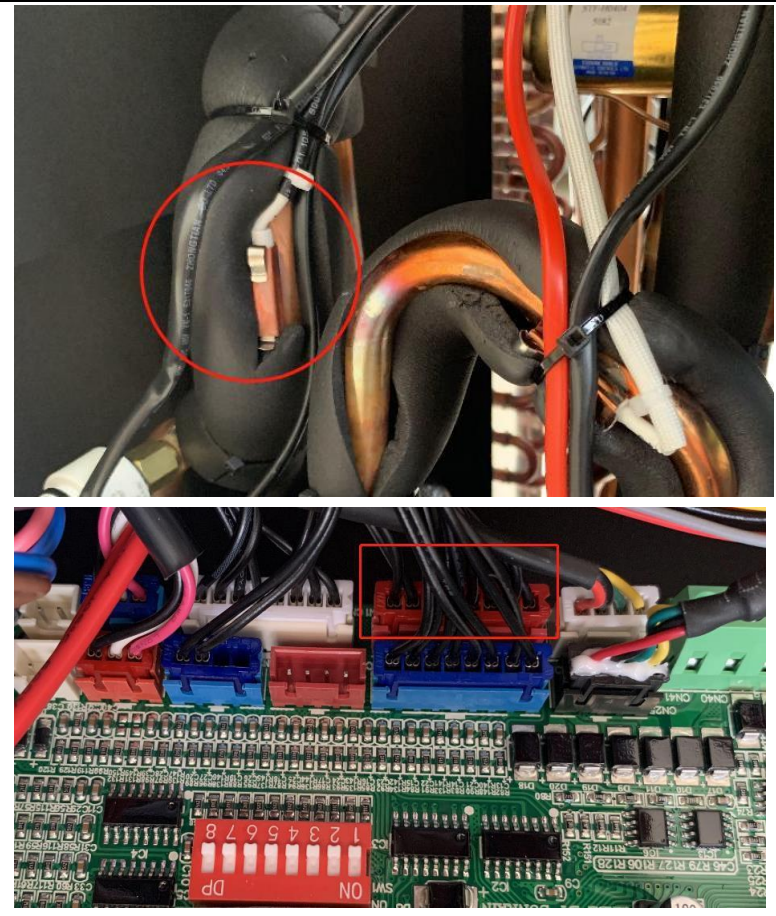
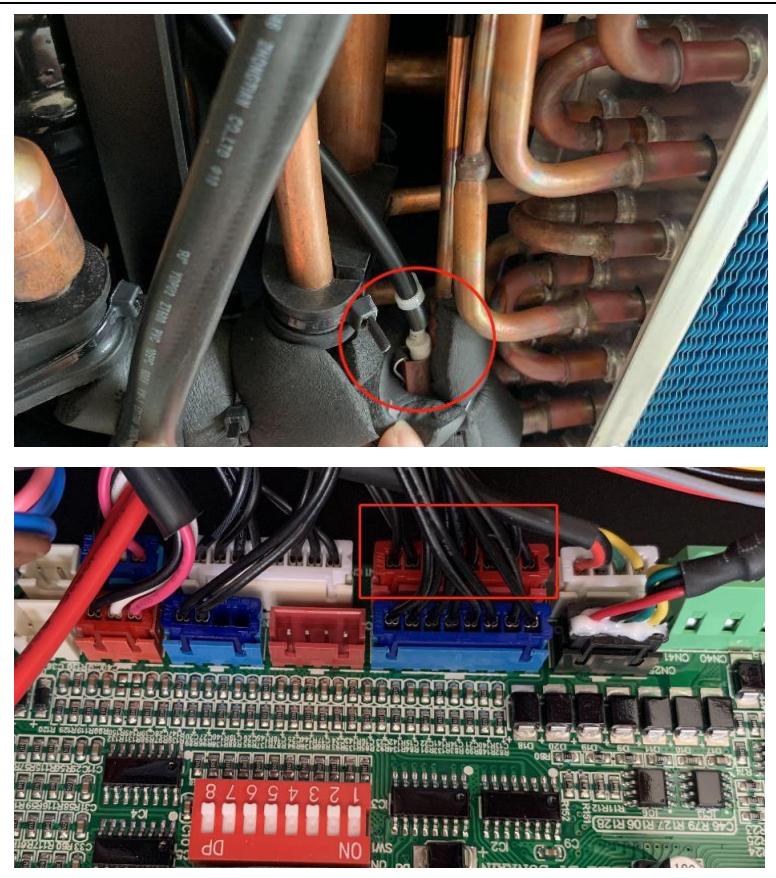
<p>27</p>		<p>T2 return air temperature sensor 5K</p>
<p>28</p>		<p>T1 coil temperature sensor 5K</p>

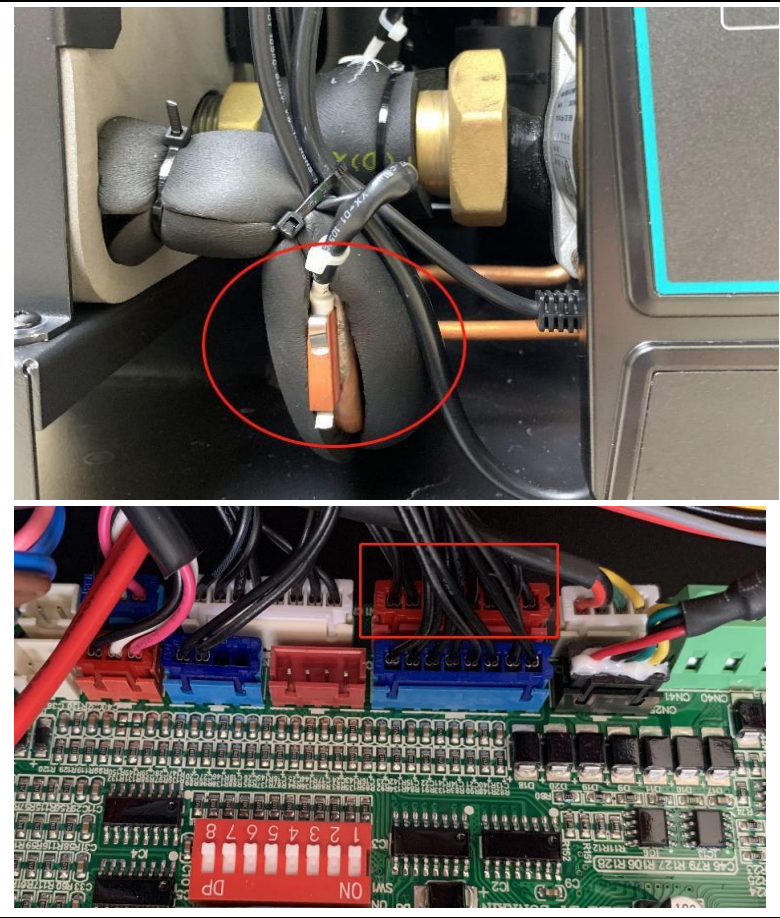
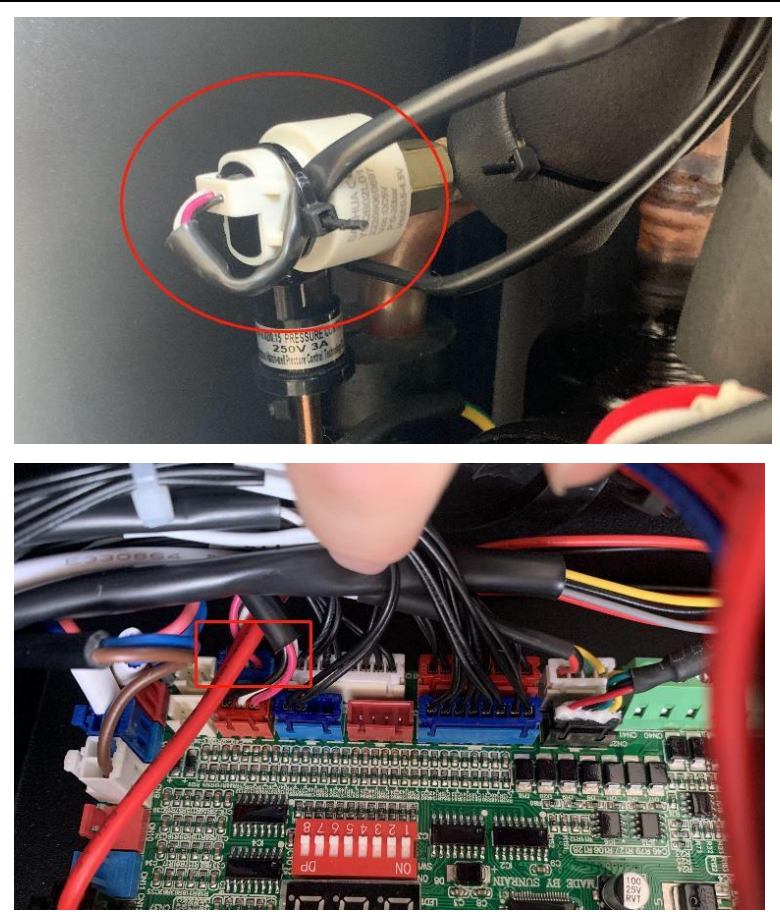
<p>29</p>		<p>T4 inner coil temperature sensor 5K</p>
<p>30</p>		<p>Low pressure pressure sensor (blue) A13</p>

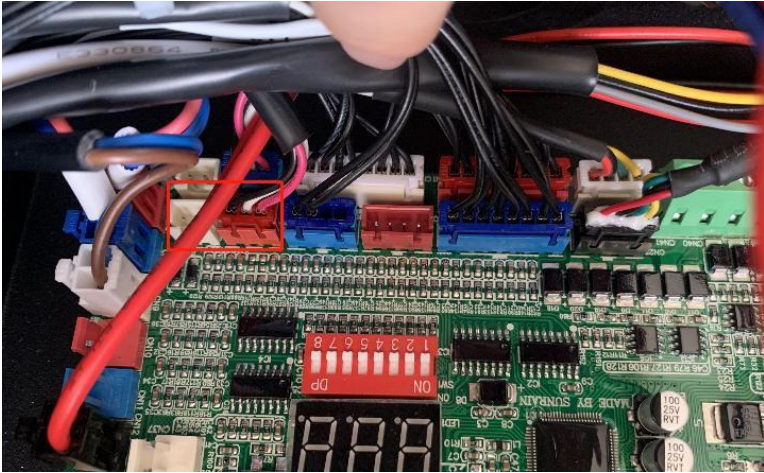
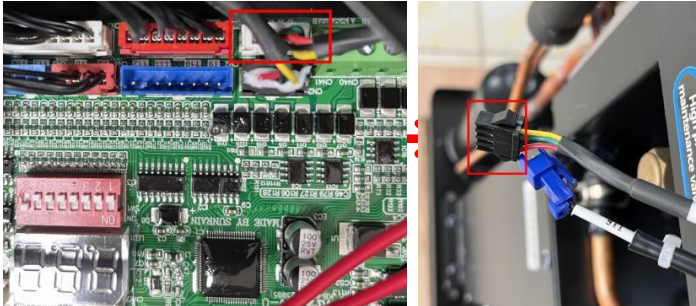
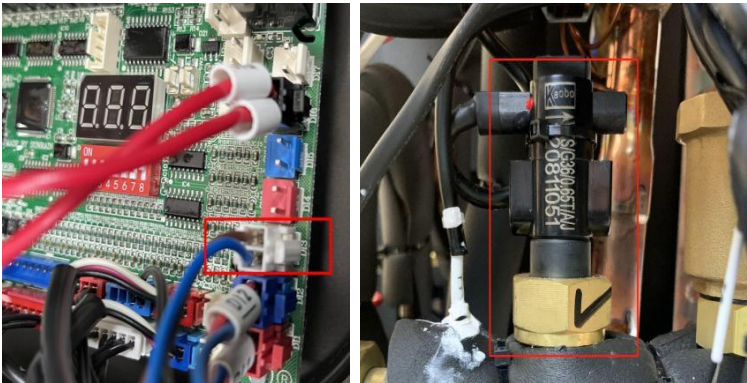
<p>31</p>	 	<p>High pressure pressure sensor (red) A14</p>
<p>32</p>		<p>wire controller</p>
<p>33</p>		<p>Water flow switch DI3</p>

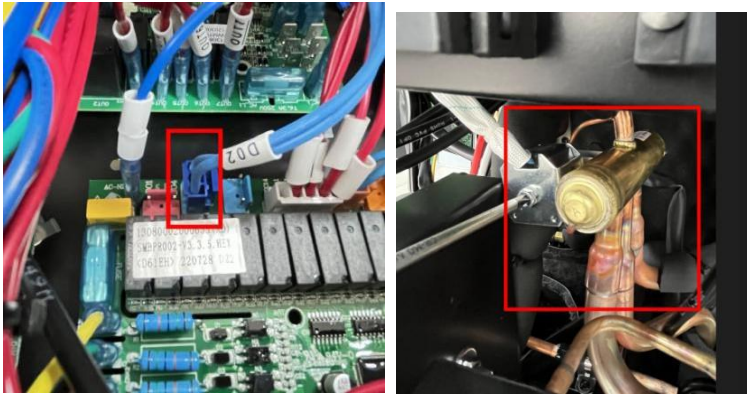
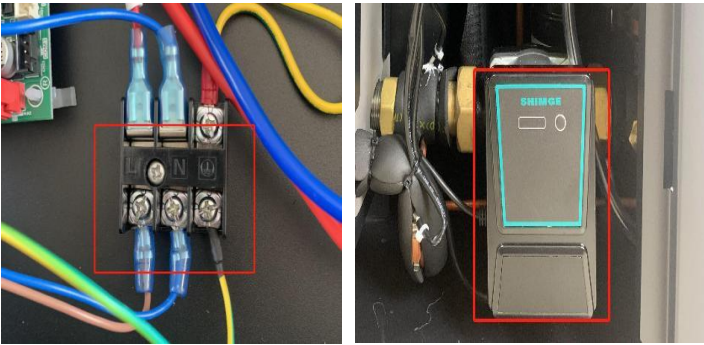
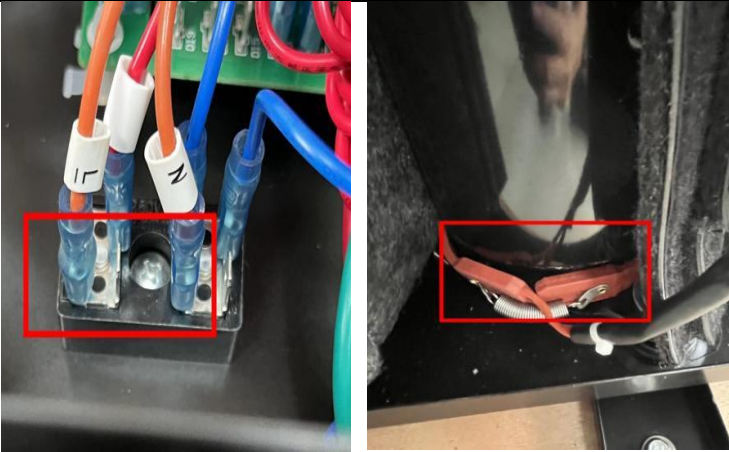
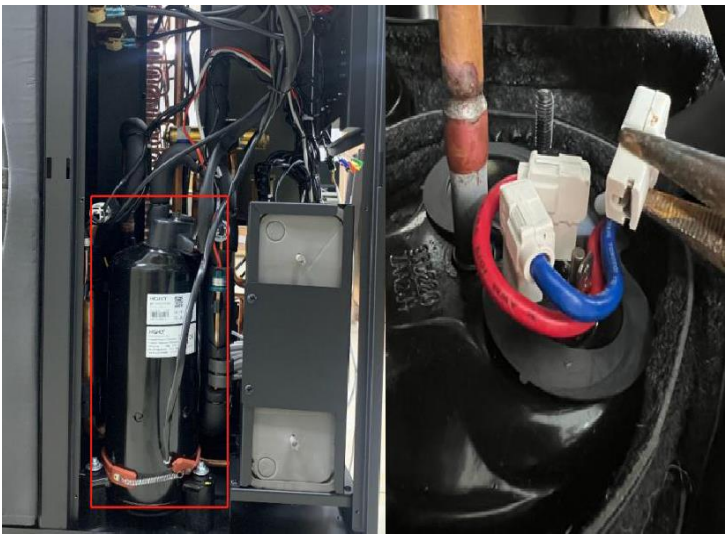
34		Four-way valve D02
35		OUT1 Circulating water pump OUT1
36		Compressor heating cable
37		ompressor

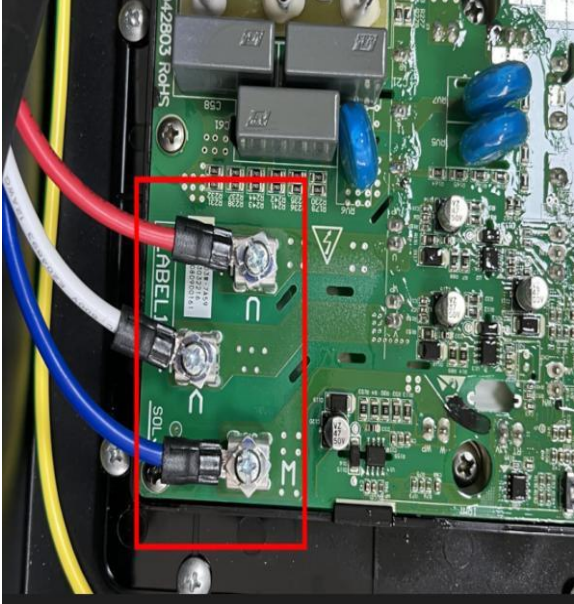
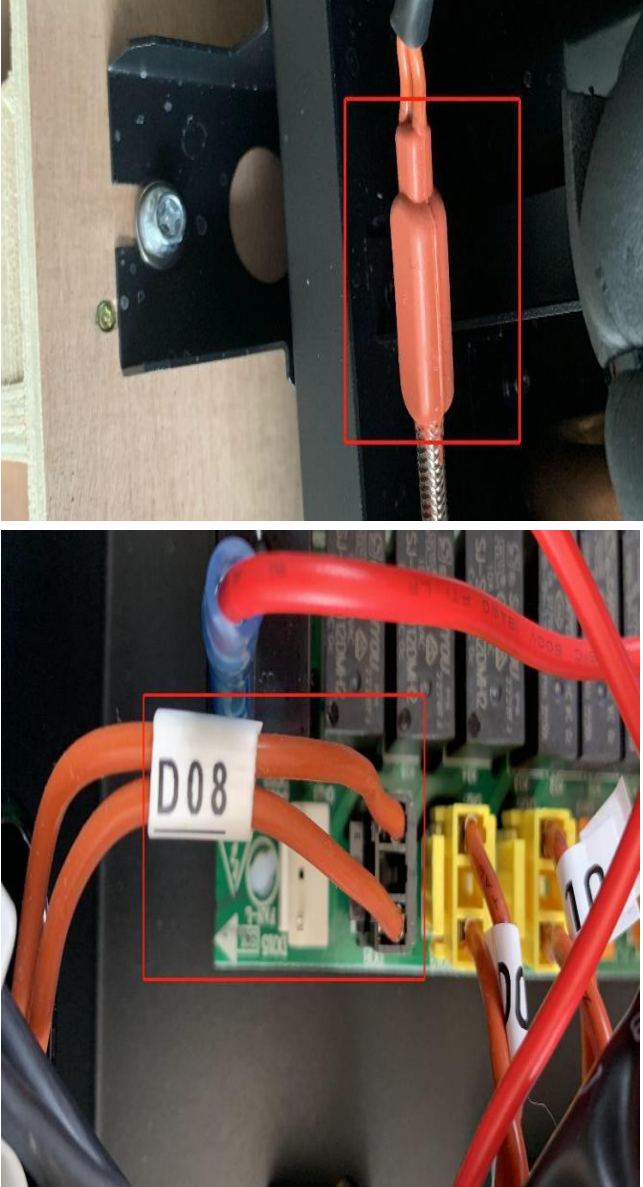
		
38		Chassis electric heating D08



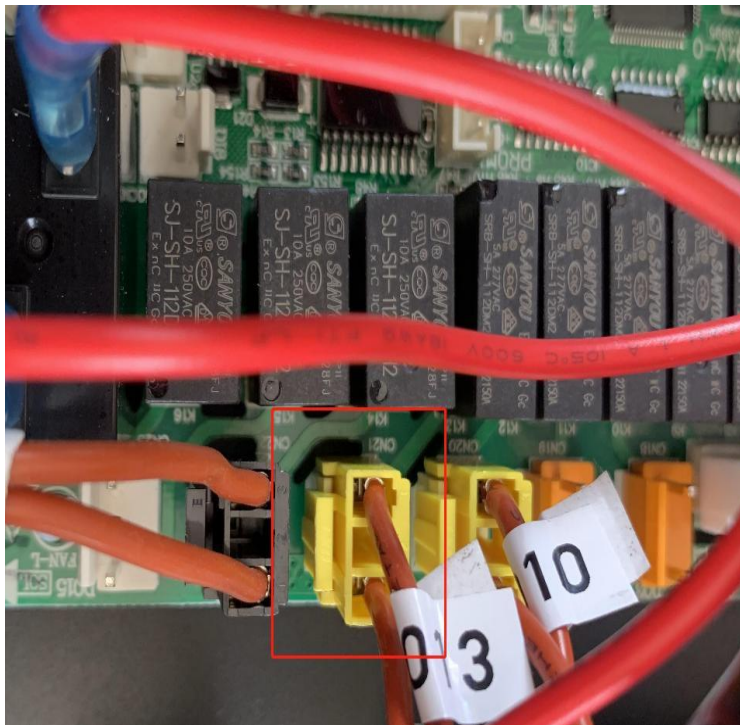

39

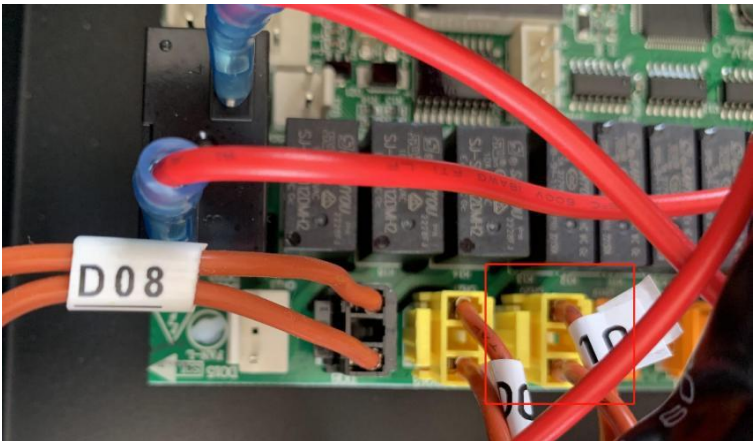
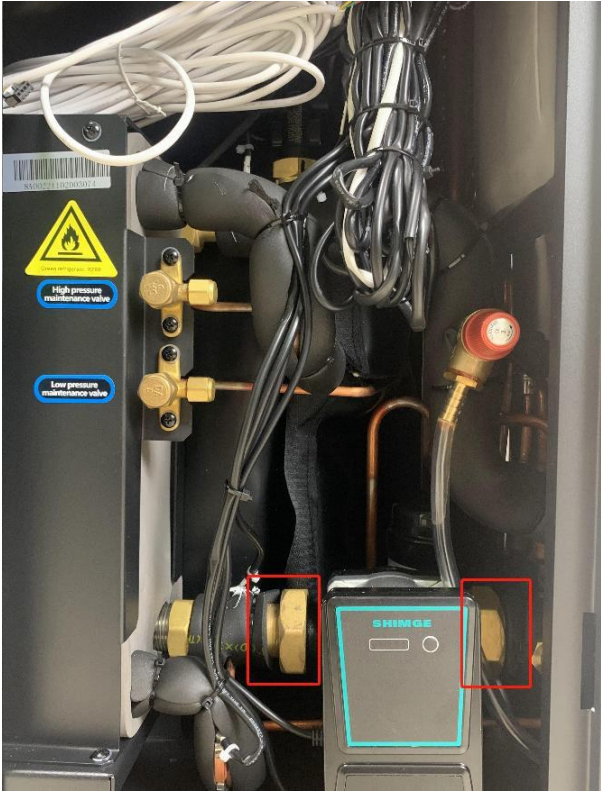

Expansion tank
electric heating
D10

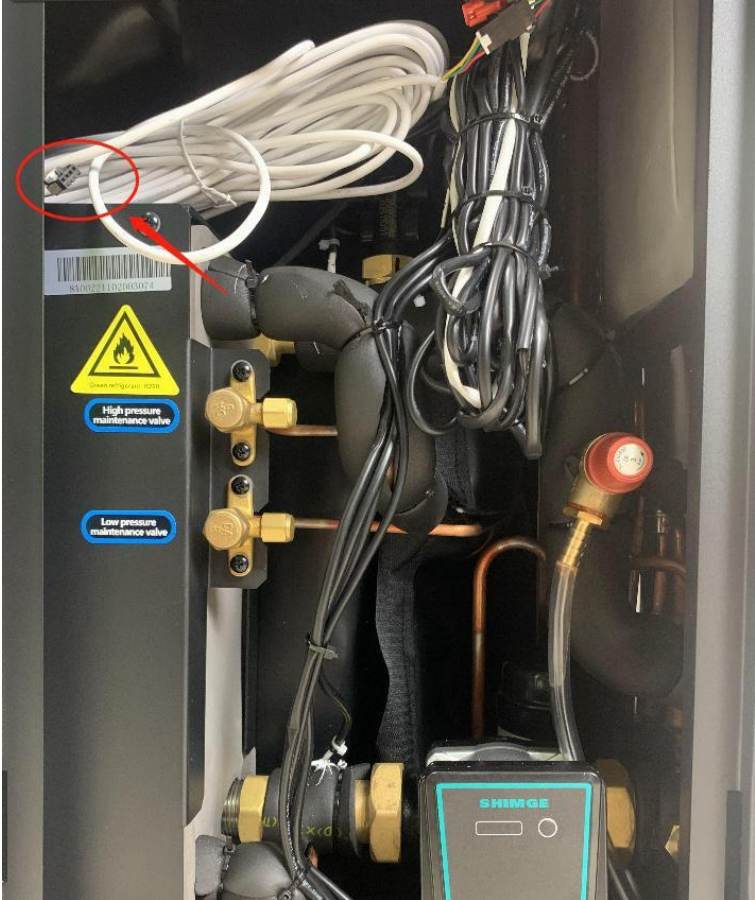
40	 	Plate replacement heating D013
41		Removal of the circulating water pump: Use a large adjustable wrench or pipe wrench to remove the joints on both sides of the water pump.

42	 A close-up photograph of the control panel of a heat pump. A red circle highlights a terminal on the left side, with a red arrow pointing to it. The panel features a yellow warning triangle with a flame icon, a barcode, and two blue labels: "High pressure maintenance valve" and "Low pressure maintenance valve". Various copper pipes, valves, and electrical wires are visible in the background.	Connect the indoor remote
43	 A photograph of a heat pump unit. A red rectangular box highlights a vertical section on the left side of the unit, which is the expansion tube. The unit is surrounded by copper piping and a blue mesh filter on the right side.	expansion tube

<p>44</p>		<p>Plate heat exchanger</p>
<p>45</p>		<p>User wiring port: N is the zero line, R, S, T are live wires</p>

46



Reactor (red)

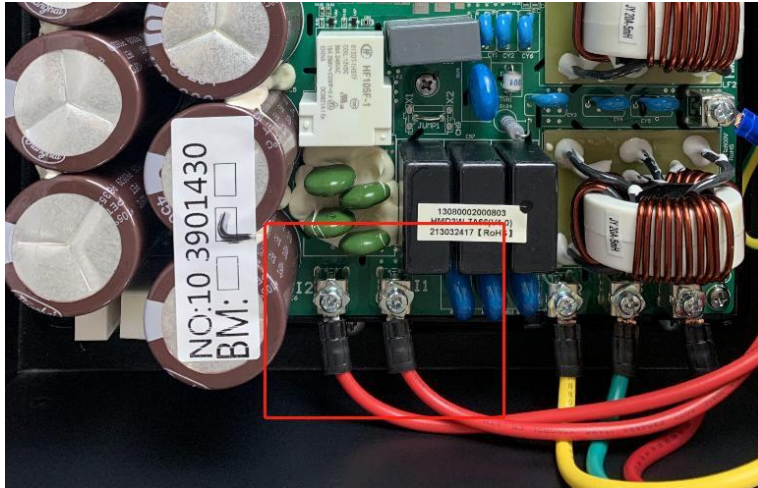

47

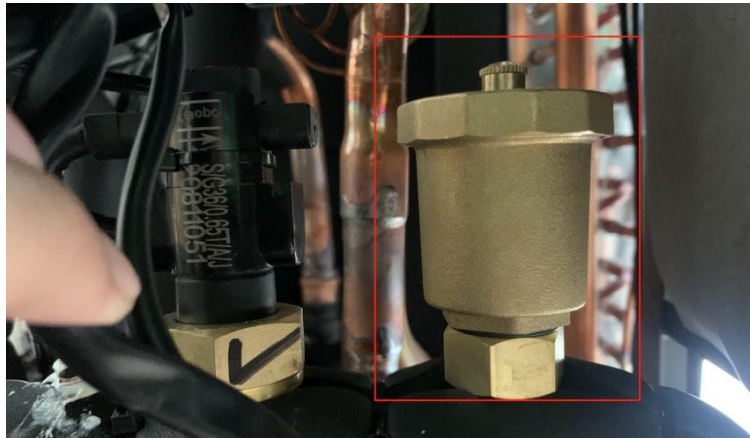

Auto exhaust valve

4.3. Troubleshooting and maintenance of common fault codes

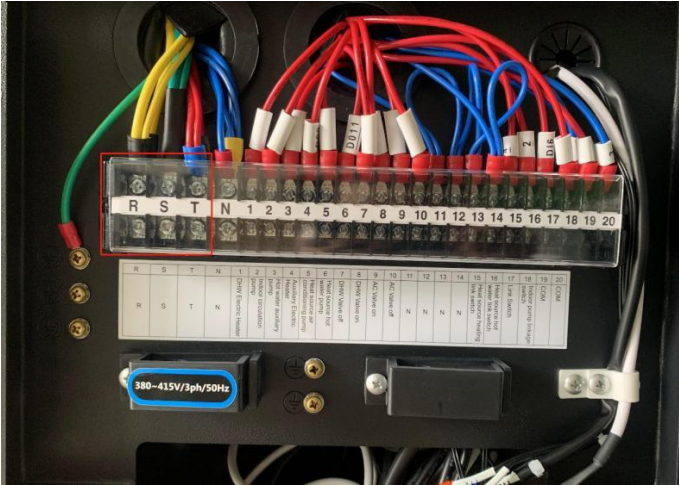
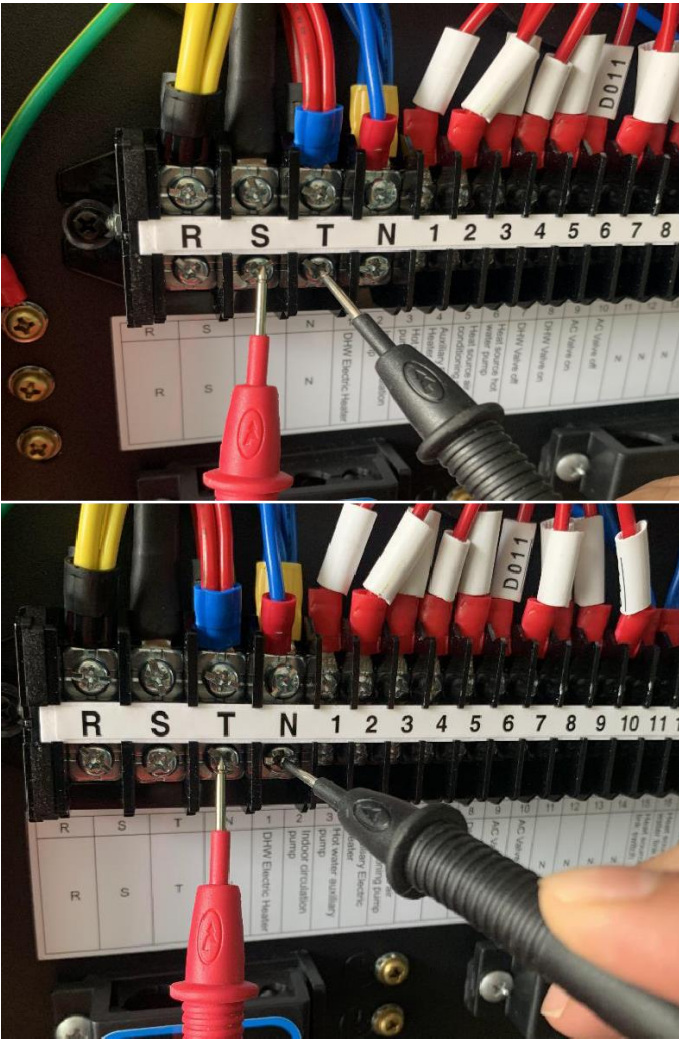
<p>E01: wrong phase protection</p>		<p>Maintenance method: R, S, T three live wires can be exchanged for any two (after the exchange, power on again). (220v machines will not have this failure.)</p>
<p>E02: Phase loss fault</p>		<p>Maintenance method: Step 1: Check whether the power cord is firmly connected. Step 2: Use a multimeter to measure whether there is 220V voltage between the neutral wire and each live wire. (It needs to be measured under the power-on state). Step 3: Use a multimeter to measure whether there is 380V voltage between the three live wires. (It needs to be measured under power-on state). (220v machines will not have this failure.)</p>

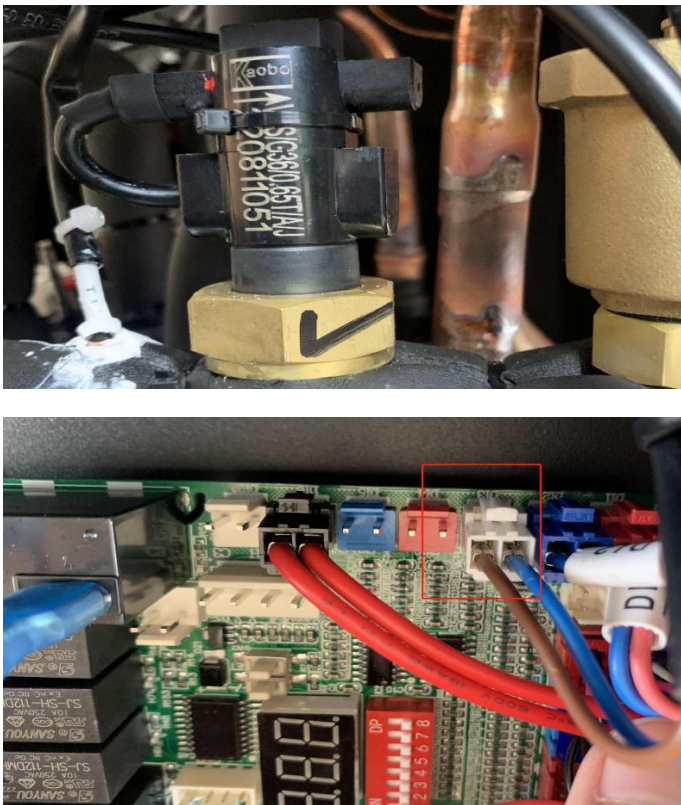
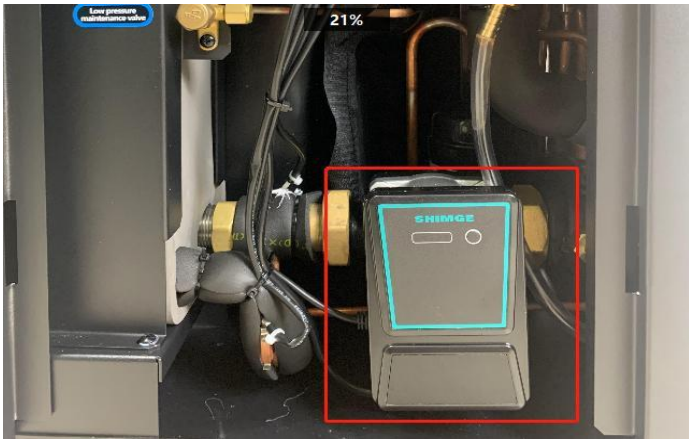

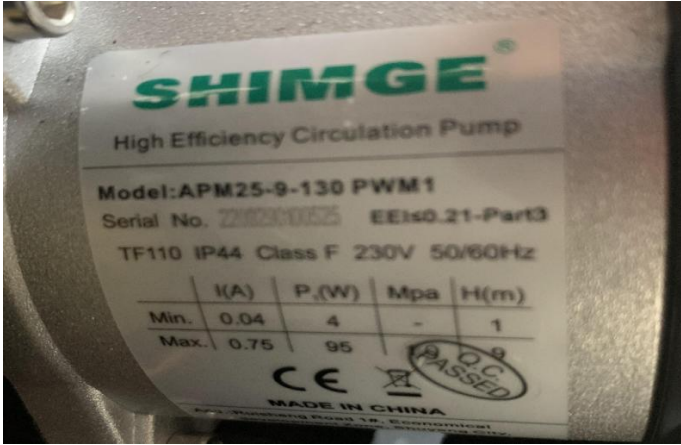
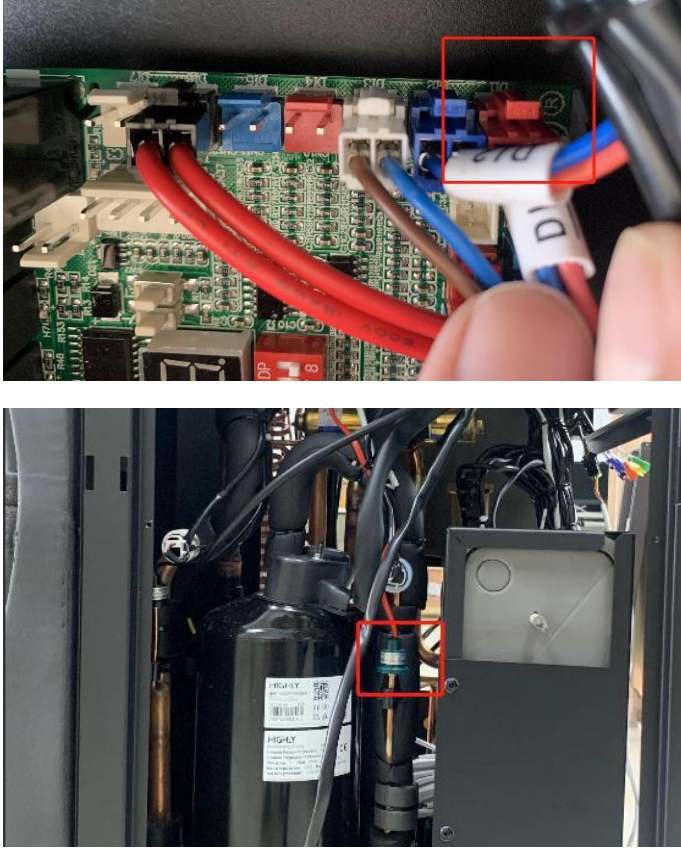
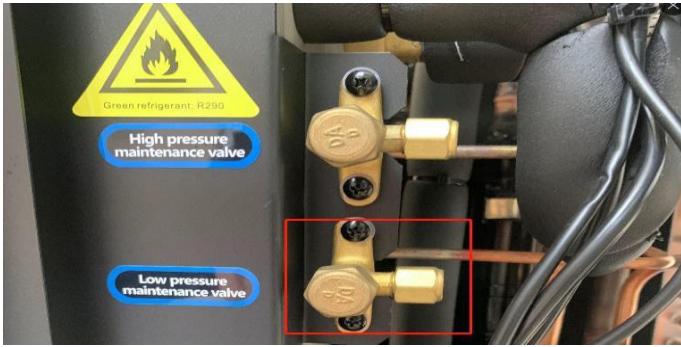
<p>E03: water flow switch failure or low water flow protection</p>		<p>Maintenance method:</p> <p>Step 1: Check whether the pipeline valve is fully open. (Make sure the water flow is clear.)</p> <p>Step 2: Check whether the water flow switch is installed backwards and whether the model of the water flow switch is correct.</p> <p>Step 3: Check whether the port of the connection line of the water flow switch is inserted in the wrong position. (water flow switch port D13 white)</p>
<p>E03: water flow switch failure or low water flow protection</p>		<p>Step 4: Check whether the circulating water pump is working normally and whether the water system is blocked.</p> <p>Step 5: Check the head of the water pump and whether the flow is sufficient. (If it is not enough, you need to add a hot water auxiliary pump.)</p> <p>Step 6: Check whether the external auxiliary pump is reversed or</p>

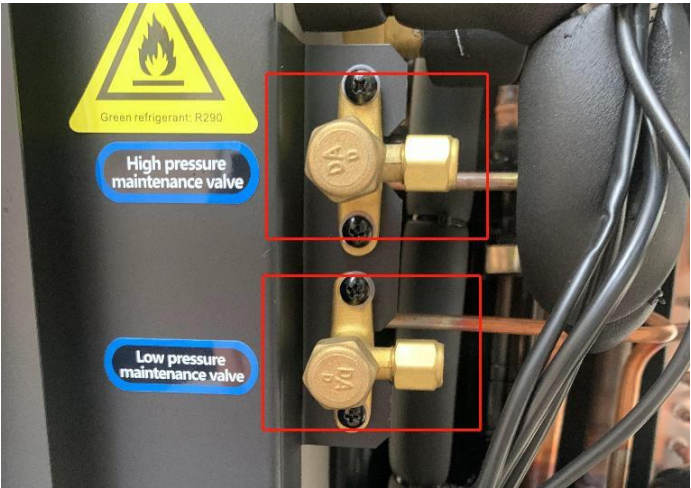
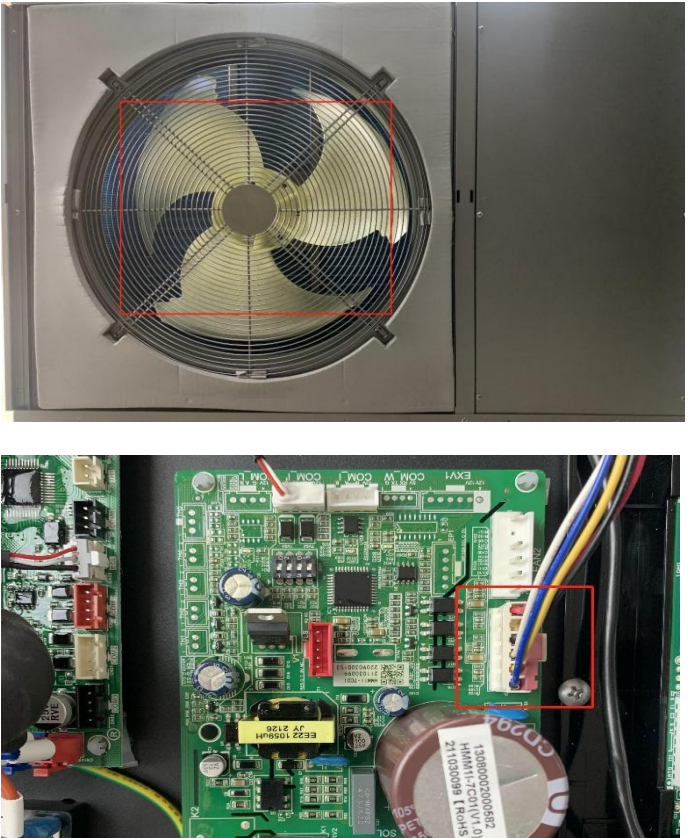
	 <p>SHIMGE[®] High Efficiency Circulation Pump</p> <p>Model: APM25-9-130 PWM1 Serial No. Z18030155 EE1x0.21-Part3 TF110 IP44 Class F 230V 50/60Hz</p> <table border="1"> <thead> <tr> <th></th> <th>I(A)</th> <th>P.(W)</th> <th>Mpa</th> <th>H(m)</th> </tr> </thead> <tbody> <tr> <td>Min.</td> <td>0.04</td> <td>4</td> <td>-</td> <td>1</td> </tr> <tr> <td>Max.</td> <td>0.75</td> <td>95</td> <td></td> <td></td> </tr> </tbody> </table> <p>CE PASSED MADE IN CHINA</p>		I(A)	P.(W)	Mpa	H(m)	Min.	0.04	4	-	1	Max.	0.75	95			<p>reversed.</p>
	I(A)	P.(W)	Mpa	H(m)													
Min.	0.04	4	-	1													
Max.	0.75	95															
<p>E05: High voltage switch failure</p>		<p>Step 1: Check whether the high-pressure pressure switch is damaged and whether the wiring terminals are correct. (High voltage switch D11 red)</p>															
<p>E05: High voltage switch failure</p>		<p>Step 2: Use a pressure gauge to connect to the low-pressure inspection port to measure too much refrigerant in the system.</p>															

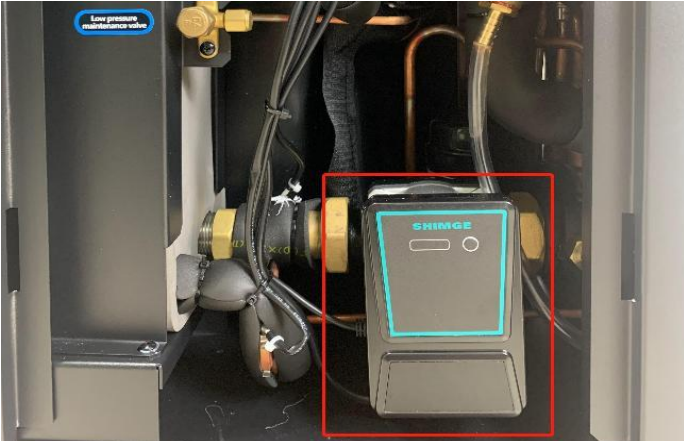
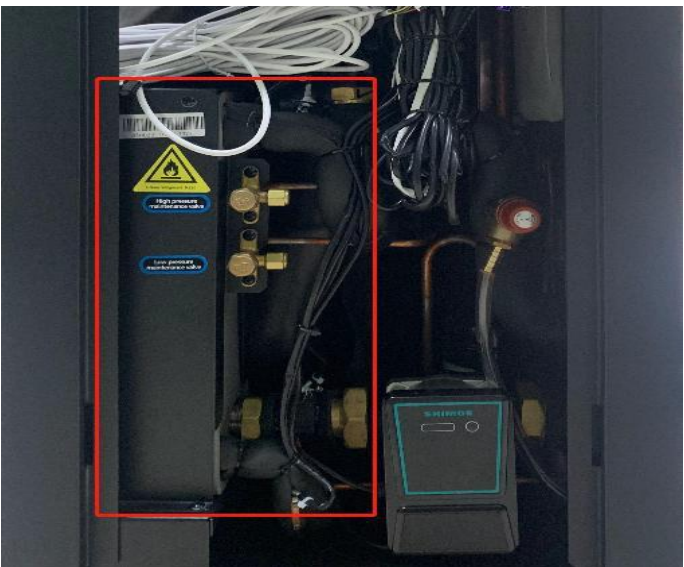
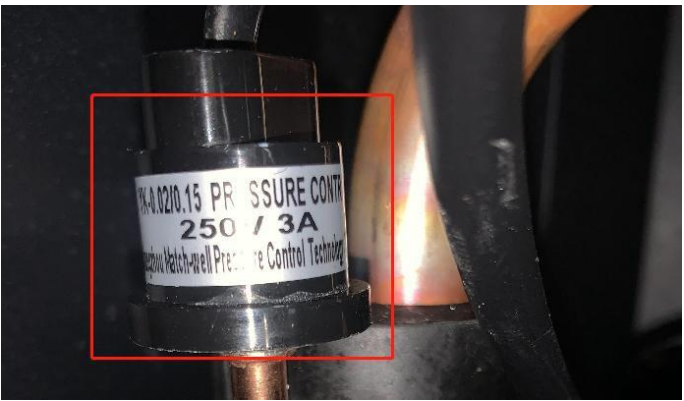
<p>E05: High voltage switch failure</p>		<p>Step 3: Check the system for blockage or air in the system. Use a pressure gauge to connect the high and low pressure inspection ports at the same time to measure whether the operating pressure of the system is normal.</p>
<p>E05: High voltage switch failure</p>		<p>Step 4: Check whether the fan is operating normally.</p>

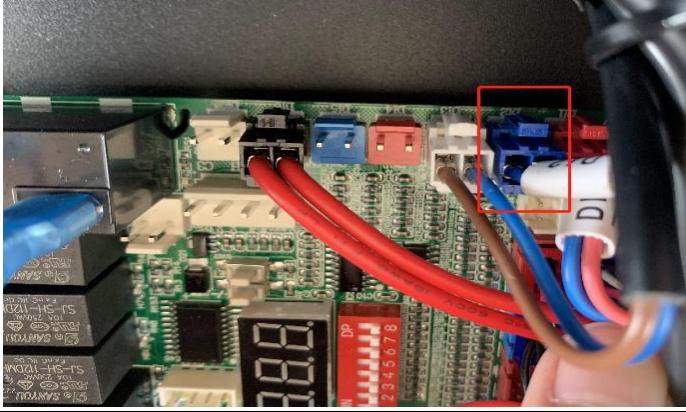
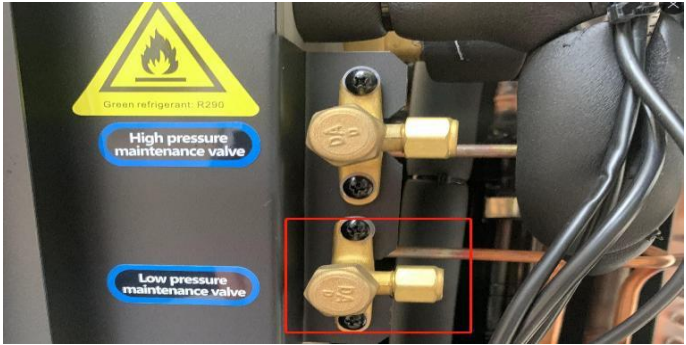
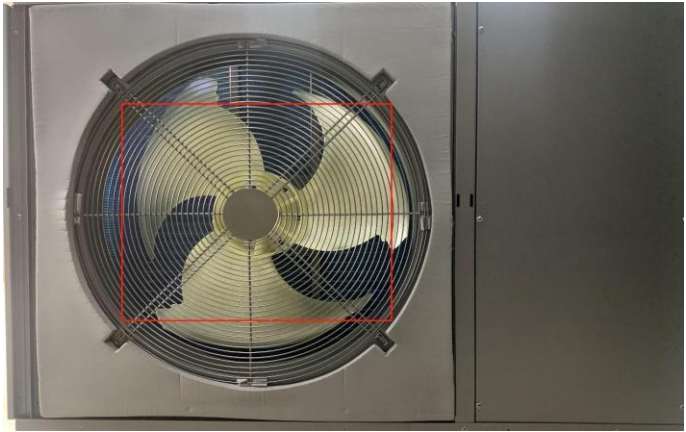
<p>E05: High voltage switch failure</p>		<p>Step 5: Check whether the water pump is running normally and whether the water flow of the unit is normal.</p>
<p>E05: High voltage switch failure</p>		<p>Step 6: Check whether the fouling of the water side heat exchanger is serious. (In areas with poor water quality, oxalic acid and citric acid should be used to clean the inside of the heat exchanger regularly, or a cold water pre-filter should be installed.)</p>
<p>E06: Low voltage switch failure</p>		<p>Step 1: Check whether the low-pressure pressure switch is damaged and whether the wiring terminals are correct. (low voltage switch D12 blue)</p>

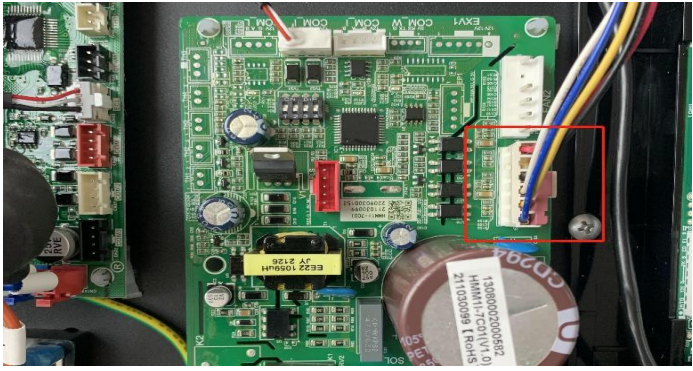
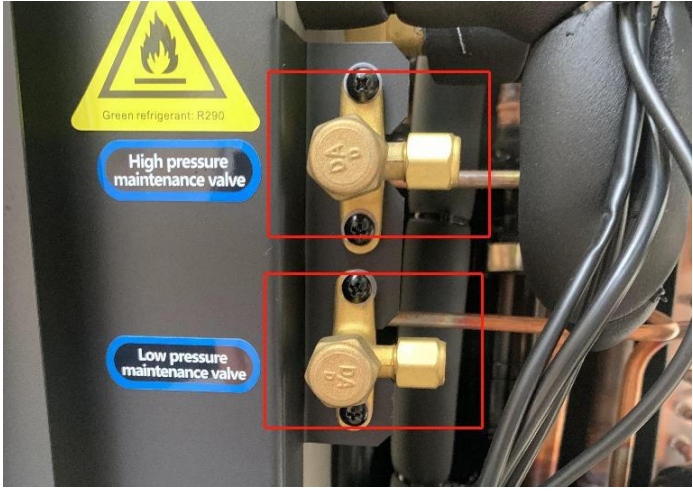
		
<p>E06: Low voltage switch failure</p>		<p>Step 2: Use a pressure gauge to connect the low-pressure inspection port to measure whether the refrigerant in the system is missing. (After supplementing the refrigerant, use foam to check whether there is refrigerant leakage at the welding joint of the copper pipe.)</p>
<p>E06: Low voltage switch failure</p>		<p>Step 3: Check whether the fan is operating normally.</p>

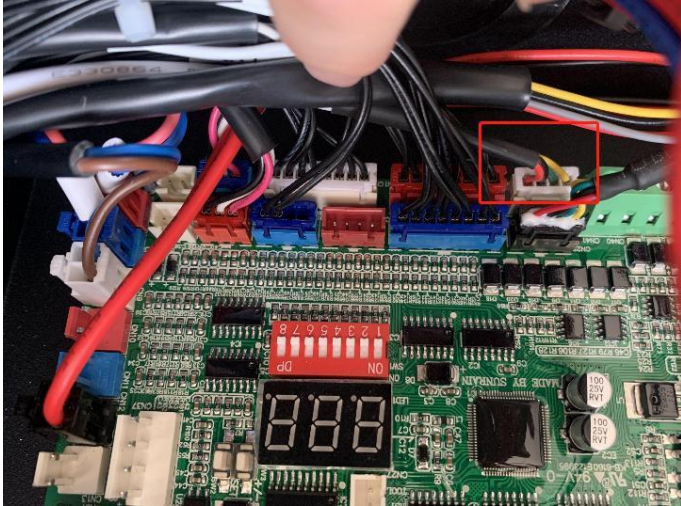
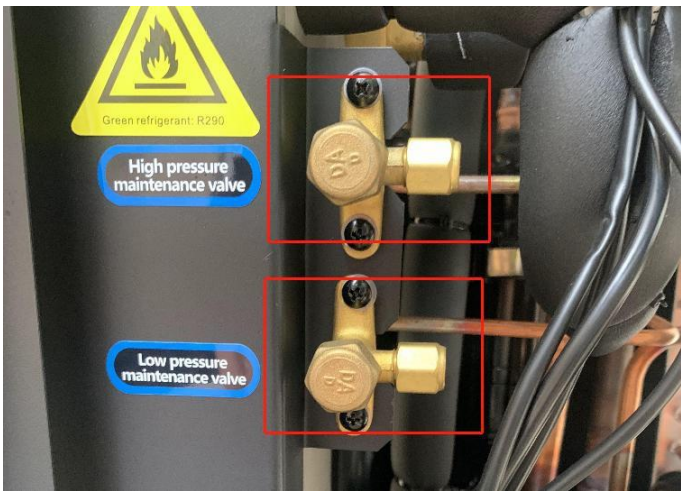
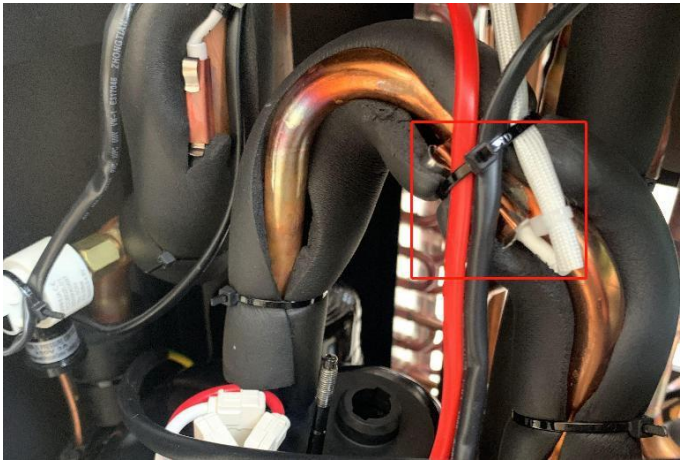

		
<p>E06: Low voltage switch failure</p>		<p>Step 4: Check the system for blockage. Use a pressure gauge to connect the high and low pressure inspection ports at the same time to measure whether the operating pressure of the system is normal.</p>
<p>E09: Communication failure between the wire controller and the main board</p>		<p>1: Check whether the communication between the wire controller and the main board is normal. 2: Use a multimeter to measure whether the voltage output of the motherboard port is normal (white port).</p>

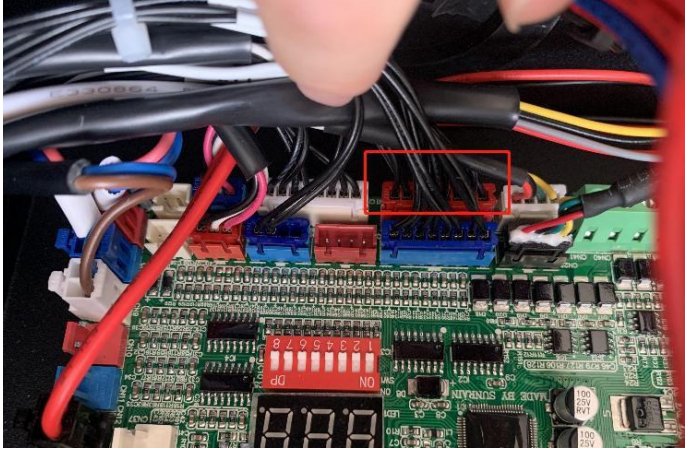
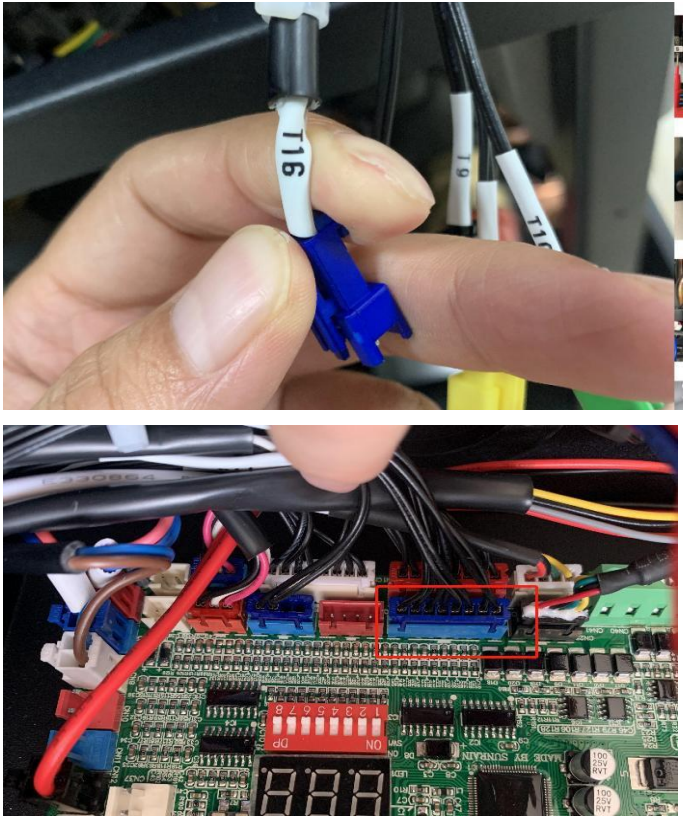
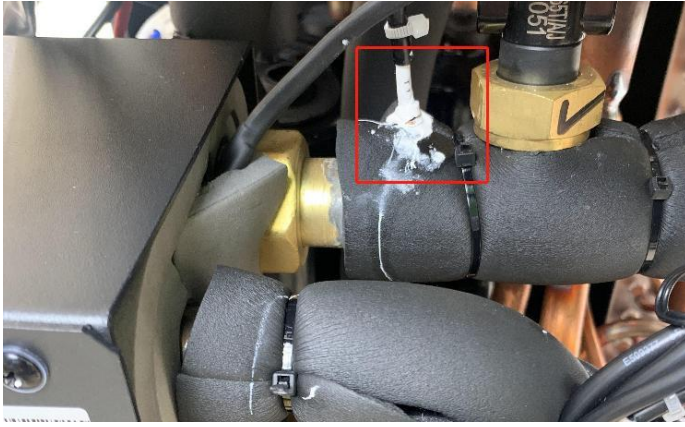
		
<p>E12: Exhaust temperatu re too high protection</p>		<p>Step 1: Check the system for blockage or lack of refrigerant. Use a pressure gauge to connect the high and low pressure inspection ports at the same time to measure whether the operating pressure of the system is normal.</p>
<p>E12: Exhaust temperatu re too high protection</p>		<p>Step 2: Check whether the exhaust gas temperature sensor is damaged and use a multimeter to measure whether the resistance value is correct (T3 red port).</p>

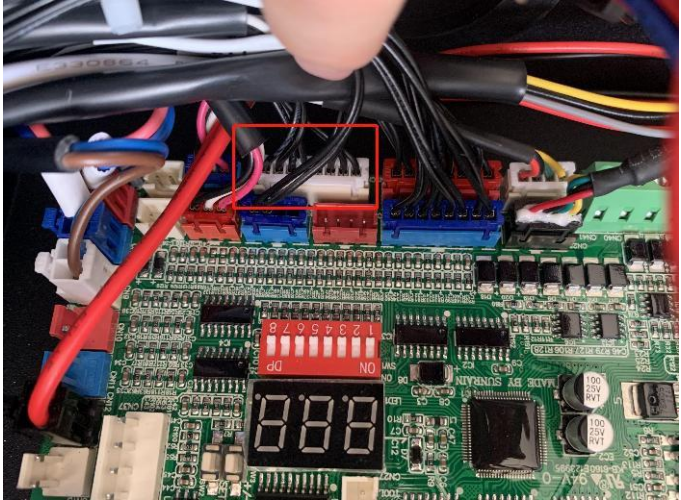
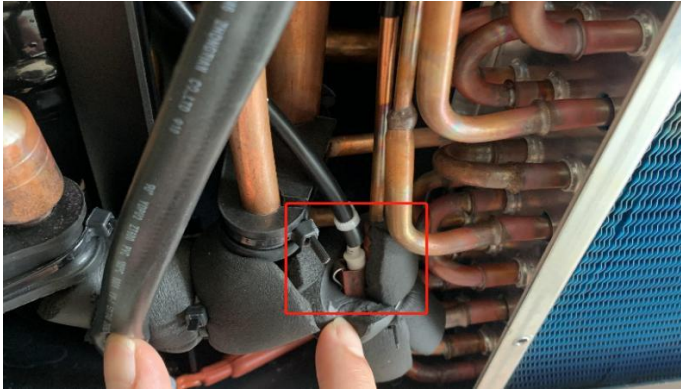
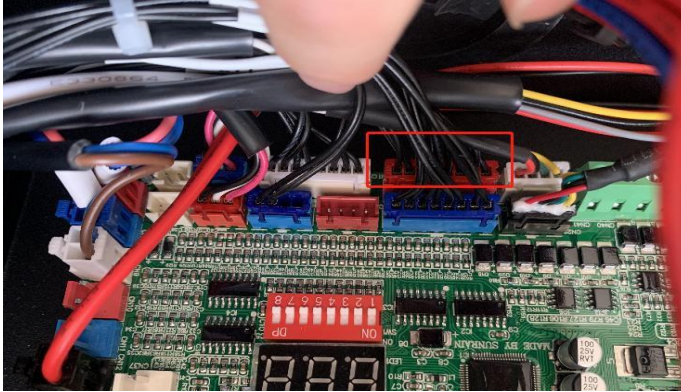
		
<p>E14: Hot water tank temperature failure</p>		<ol style="list-style-type: none"> 1: The sensor connection line is open or disconnected. 2: The sensor is damaged. 3: The motherboard port is damaged. 4: Use a multimeter to measure whether the resistance is correct (T16 blue port.)
<p>E15: Inlet water temperature sensor failure</p>		<ol style="list-style-type: none"> 1: The sensor connection line is open or disconnected. 2: The sensor is damaged. 3: The motherboard port is damaged. 4: Use a multimeter to measure whether the resistance is correct (T8 white port).

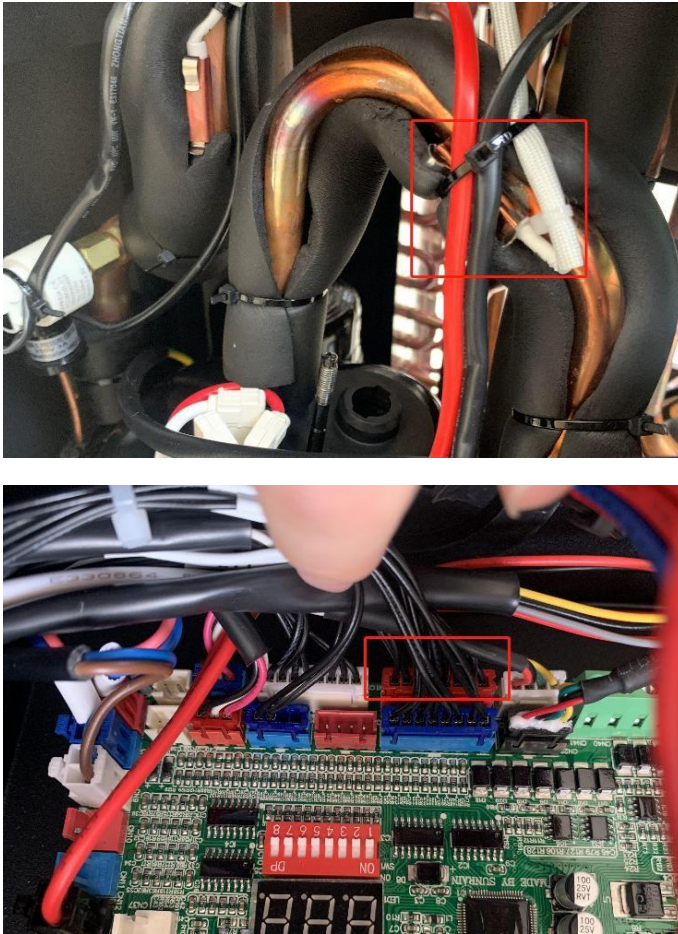
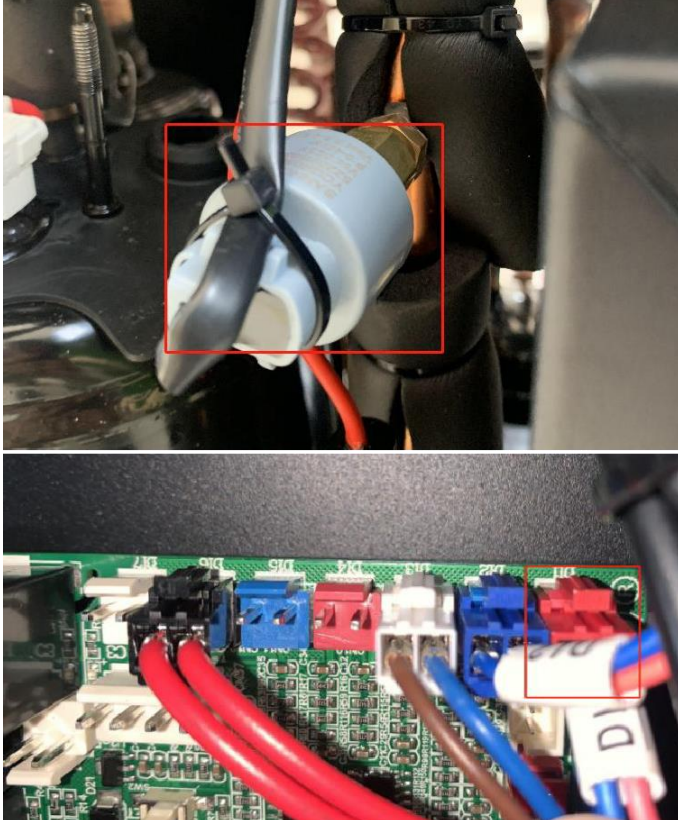
		
<p>E16: Coil sensor failure</p>	 	<ol style="list-style-type: none"> 1: The sensor connection line is open or disconnected. 2: The sensor is damaged. 3: The motherboard port is damaged. 4: Use a multimeter to measure whether the resistance value is correct (TI red port).

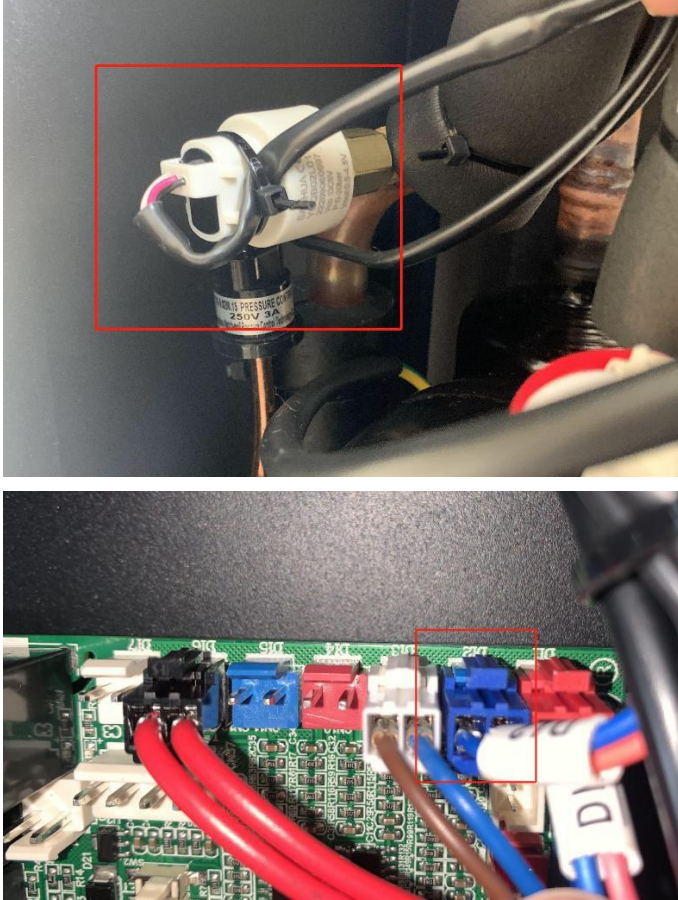
<p>E18: Exhaust sensor failure</p>		<p>1: The sensor connection line is open or disconnected. 2: The sensor is damaged. 3: The motherboard port is damaged. 4: Use a multimeter to measure whether the resistance is correct (TI red port).</p>
<p>E33: High pressure sensor failure</p>		<p>1: The sensor cable is disconnected or open. 2: Sensor failure. 3: The motherboard port is damaged (D11 red port).</p>

<p>E34: Low pressure sensor failure</p>	 <p>The top photograph shows a low pressure sensor cable disconnected from its port. The bottom photograph shows a close-up of the motherboard with a red box highlighting a damaged blue port labeled 'D12'.</p>	<p>1: The sensor cable is disconnected or open. 2: Sensor failure. 3: The motherboard port is damaged (D12 blue port).</p>
<p>E37: Too large temperature difference between inlet and outlet water protection</p>	 <p>The photograph shows the internal components of a heat pump unit, including pipes, valves, and a control panel. A red box highlights the control panel, which has a digital display and buttons.</p>	<p>Step 1: Check whether the pipeline valve is fully open. Step 2: Check if the water pump is working. Step 3: Check the rated head of the pump and whether the rated flow meets the requirements for normal operation of the machine. Step 4: Manually drain the drain pump and pipe air.</p>

Schedule

Schedule A: Unit Ground Heat Dissipation and Ground-to-Soil Heat Loss

(1) Heat dissipation per unit ground area of PE-X pipe and heat loss when turning downwards

When the ground layer is made of cement or ceramics, and the thermal resistance is <0.02 ($m^2.K/W$), the heat dissipation per unit of ground and the heat loss of downward transfer can be calculated according to Table A1.1.

Table A 1.1

average water temperature (°C)	indoor air temperature (°C)	Heating tube spacing (mm)									
		300		250		200		150		100	
		Heat output	heat loss	Heat output	heat loss	Heat output	heat loss	Heat output	heat loss	Heat output	heat loss
35	16	84.7	23.8	92.5	24.0	100.5	24.6	108.9	24.8	116.6	24.8
	18	76.4	21.7	83.3	22.0	90.4	22.6	97.9	22.7	104.7	22.7
	20	68.0	19.9	74.0	20.2	80.4	20.5	87.1	20.5	93.1	20.5
	22	59.7	17.7	65.0	18.0	70.5	18.4	76.3	18.4	81.5	18.4
	24	51.6	15.6	56.1	15.7	60.7	15.7	65.7	15.7	70.1	15.7
40	16	108.0	29.7	118.1	29.8	128.7	30.5	139.6	30.8	149.7	30.8
	18	99.5	27.4	108.7	27.9	118.4	28.5	128.4	28.7	137.6	28.7
	20	91.0	25.4	99.4	25.7	108.1	26.5	117.3	26.7	125.6	26.7
	22	82.5	23.8	90.0	23.9	97.9	24.4	106.2	24.6	113.7	24.6
	24	74.2	21.3	80.9	21.5	87.8	22.4	95.2	22.4	101.9	22.4
45	16	131.8	35.5	144.4	35.5	157.5	36.5	171.2	36.8	183.9	36.8
	18	123.3	33.2	134.8	33.9	147.0	34.5	159.8	34.8	171.6	34.8
	20	114.5	31.7	125.3	32.0	136.6	32.4	148.5	32.7	159.3	32.7
	22	106.0	29.4	115.8	29.8	126.2	30.4	137.1	30.7	147.1	30.7
	24	97.3	27.6	106.5	27.3	115.9	28.4	125.9	28.6	134.9	28.6
50	16	156.1	41.4	171.1	41.7	187.0	42.5	203.6	42.9	218.9	42.9
	18	147.4	39.2	161.5	39.5	176.4	40.5	192.0	40.9	206.4	40.9
	20	138.6	37.3	151.9	37.5	165.8	38.5	180.5	38.9	194.0	38.9
	22	130.0	35.2	142.3	35.6	155.3	36.5	168.9	36.8	181.5	36.8
	24	121.2	33.4	132.7	33.7	144.8	34.4	157.5	34.7	169.1	34.7
55	16	180.8	47.1	198.3	47.8	217.0	48.6	236.5	49.1	254.8	49.1
	18	172.0	45.2	188.7	45.6	206.3	46.6	224.9	47.1	242.0	47.1
	20.0	163.1	43.3	178.9	43.8	195.6	44.6	213.2	45.0	229.4	45.0
	22.0	154.3	41.4	169.3	41.5	185.0	42.5	201.5	43.0	216.9	43.0
	24.0	145.5	39.4	159.6	39.5	174.3	40.5	189.9	40.9	204.3	40.9

Calculation conditions: the nominal outer diameter of the heating pipe is 20mm, the thickness of the filling layer is 50mm, the thickness of the polystyrene foam insulation layer is 20mm, and the temperature difference between the supply and return water is 10°C.

When the ground layer is made of plastic materials and thermal resistance = 0.075 (m².K/W), the heat dissipation per unit of ground and the heat loss when turning downwards can be calculated according to Table A1.2.

Table A 1.2

average water temperature (°C)	indoor air temperature (°C)	Heating tube spacing (mm)									
		300		250		200		150		100	
		Heat output	heat loss	Heat output	heat loss	Heat output	heat loss	Heat output	heat loss	Heat output	heat loss
35	16	67.7	24.2	72.3	24.3	76.8	24.6	81.3	25.1	85.3	25.7
	18	61.1	22.0	65.2	22.2	69.3	22.5	73.2	22.9	76.9	23.4
	20	54.5	19.9	58.1	20.1	61.8	20.3	65.3	20.7	68.5	21.3
	22	48.0	17.8	51.1	18.1	54.3	18.1	57.4	18.5	60.2	18.8
	24	41.5	15.5	44.2	15.9	46.9	16.0	49.5	16.3	51.9	16.7
40	16	85.9	30.0	91.8	30.4	97.7	30.7	103.4	31.3	108.7	32.0
	18	79.2	27.9	84.6	28.1	90.0	28.6	95.3	29.1	100.1	29.8
	20	72.5	26.0	77.5	26.0	82.4	26.4	87.2	26.9	91.5	27.6
	22	65.9	23.7	70.3	24.0	74.8	24.2	79.1	24.7	83.0	25.3
	24	59.3	21.4	63.2	21.9	67.2	22.1	71.1	22.5	74.6	23.1
45	16	104.5	35.8	111.7	36.1	119.0	36.8	126.1	37.6	132.6	38.5
	18	97.7	33.8	104.5	34.1	111.2	34.7	117.8	35.4	123.9	36.3
	20	90.9	31.8	97.2	32.1	103.5	32.6	109.6	33.2	115.2	33.9
	22	84.2	29.7	89.9	30.0	95.8	30.4	101.4	31.0	106.5	31.9
	24	77.4	27.7	82.7	28.0	88.1	28.2	93.2	28.8	97.9	29.4
50	16	123.3	41.8	131.9	42.2	140.6	42.9	149.1	43.9	156.9	44.9
	18	116.5	39.6	124.6	40.3	132.8	40.8	141.1	41.7	148.1	42.7
	20	109.6	37.7	117.3	38.1	125.0	38.7	132.4	39.5	139.3	40.4
	22	102.8	35.5	109.9	36.2	117.1	36.6	124.1	37.3	130.6	38.3
	24	96.0	33.7	102.7	33.9	109.4	34.4	115.9	35.1	121.8	35.9
55	16	142.4	47.7	152.3	48.6	162.5	49.1	172.4	50.2	181.5	51.4
	18	135.4	45.8	145.0	46.2	154.6	47.0	164.0	48.0	172.7	49.3
	20	128.6	43.7	137.6	41.3	146.8	44.9	155.6	45.9	163.8	47.0
	22	121.7	41.6	130.2	42.2	138.9	42.8	147.3	43.7	155.0	44.9
	24	114.9	39.6	122.9	39.9	131.0	40.7	138.9	41.5	146.2	42.6

Calculation conditions: the nominal outer diameter of the heating pipe is 20mm, the thickness of the filling layer is 50mm, the thickness of the polystyrene foam insulation layer is 20mm, and the temperature difference between the supply and return water is 10°C.

When the ground floor is made of wooden floor material and the thermal resistance is 0.1 (m².K/W), the heat dissipation per unit of ground and the heat loss from downward transfer can be calculated according to Table A 1.3.

Table A 1.3

average water temperature (°C)	indoor air temperature (°C)	Heating tube spacing (mm)									
		300		250		200		150		100	
		Heat output	heat loss	Heat output	heat loss	Heat output	heat loss	Heat output	heat loss	Heat output	heat loss
35	16	62.4	24.4	66.0	24.6	69.6	25.0	73.1	25.5	76.2	26.1
	18	56.3	22.3	59.6	22.5	62.8	22.9	65.9	23.3	68.7	23.9
	20	50.3	20.1	53.1	20.5	56.0	20.7	58.8	21.1	61.3	21.6
	22	44.3	18.0	46.8	18.2	49.3	18.5	51.7	18.9	53.9	19.3
	24	38.4	15.7	40.5	16.1	42.6	16.3	44.7	16.6	46.5	17.0
40	16	79.1	30.2	83.7	30.7	88.4	31.2	92.8	31.9	96.9	32.5
	18	72.9	28.3	77.2	28.6	81.5	29.0	85.5	29.6	89.3	30.3
	20	66.8	26.3	70.7	26.5	74.6	26.9	78.3	27.4	81.7	28.1
	22	60.7	24.0	64.2	24.4	67.7	24.7	71.1	25.2	74.1	25.8
	24	54.6	21.9	57.8	22.1	60.9	22.5	63.9	22.9	66.6	23.4
45	16	96.0	36.4	101.8	36.9	107.5	37.5	112.9	38.2	117.9	39.1
	18	89.8	34.1	95.1	34.8	100.5	35.3	105.6	36.0	110.2	36.8
	20	83.6	32.2	88.6	32.7	93.5	33.1	98.2	33.8	102.6	34.5
	22	77.4	30.1	82.0	30.4	86.6	30.9	90.9	31.6	94.9	32.4
	24	71.2	28.0	75.4	28.4	79.6	28.8	83.6	29.3	87.3	30.0
50	16	113.2	42.3	120.0	43.1	126.8	43.7	133.4	44.6	139.3	45.6
	18	106.9	40.3	113.3	41.0	119.8	41.6	125.9	42.4	131.6	43.4
	20	100.7	38.1	106.7	38.7	112.7	39.4	118.5	40.2	123.8	41.2
	22	94.4	36.1	100.1	36.7	105.7	37.2	111.1	38.0	116.1	38.9
	24	88.2	34.0	93.4	34.6	98.7	35.1	103.8	35.7	108.4	36.6
55	16	130.5	48.6	138.5	49.1	146.4	50.0	154.0	51.1	161.0	52.2
	18	124.2	46.6	131.8	47.1	139.3	47.9	146.6	48.9	153.2	50.0
	20	118.0	44.4	125.1	45.0	132.2	45.7	139.1	46.7	145.4	47.8
	22	111.7	42.2	118.4	42.8	125.2	43.6	131.6	44.5	137.6	45.5
	24	105.4	40.1	111.7	40.8	118.1	41.4	124.2	42.2	129.8	43.2

Calculation conditions: the nominal outer diameter of the heating pipe is 20mm, the thickness of the filling layer is 50mm, the thickness of the polystyrene foam insulation layer is 20mm, and the temperature difference between the supply and return water is 10°C.

(2) Heat dissipation per unit ground area of PB pipe and heat loss when turning downwards

When the ground layer is made of cement or ceramics, and the thermal resistance is <0.02 (m².K/W), the heat dissipation per unit of ground and the heat loss of downward transfer can be calculated according to Table A 2.1.

Table A 2.1

average water temperature (°C)	indoor air temperature (°C)	Heating tube spacing (mm)									
		300		250		200		150		100	
		Heat output	heat loss	Heat output	heat loss	Heat output	heat loss	Heat output	heat loss	Heat output	heat loss
35	16	76.5	21.9	84.3	22.3	92.7	22.9	101.8	23.7	111.1	24.1
	18	68.9	20.1	75.9	20.4	83.5	20.9	91.5	21.7	99.8	22.6
	20	61.4	18.2	67.5	18.7	74.3	19.0	81.4	19.6	88.6	20.6
	22	53.9	16.5	59.3	16.8	65.1	17.2	71.4	17.5	77.6	18.5
	24	46.6	14.6	51.2	14.8	56.1	15.3	61.4	15.7	66.8	16.4
40	16	97.3	27.1	107.4	27.6	118.5	28.3	130.3	29.2	142.4	30.6
	18	89.6	25.4	98.9	25.9	109.1	26.4	119.9	27.2	130.9	28.6
	20	82.0	23.5	90.4	24.1	99.6	24.6	109.5	25.2	119.5	26.5
	22	74.4	21.7	82.0	22.1	90.3	22.7	99.2	23.3	108.2	24.4
	24	66.8	19.9	73.6	20.3	81.0	20.8	88.9	21.5	96.9	22.4
45	16	118.6	32.4	131.1	33.0	144.9	33.8	159.6	35.1	174.7	36.6
	18	110.8	30.6	122.5	31.2	135.3	31.9	149.0	33.0	163.1	34.6
	20	103.1	28.8	113.9	29.4	125.7	30.0	138.4	31.2	151.4	32.5
	22	95.3	27.0	105.3	27.5	116.2	28.2	127.9	29.1	139.8	30.5
	24	87.7	25.2	96.7	25.6	106.7	26.3	117.4	27.2	128.3	28.4
50	16	140.3	37.6	155.2	38.4	171.8	39.4	189.5	40.8	207.9	42.7
	18	132.4	35.8	146.5	36.5	162.1	37.5	178.8	38.9	196.0	40.6
	20	124.6	34.0	137.8	34.7	152.4	35.7	168.1	36.8	184.2	38.6
	22	116.8	32.2	129.1	32.9	142.7	33.8	157.3	35.0	172.4	36.6
	24	109.0	30.5	120.4	31.1	133.1	31.9	146.7	32.9	160.7	34.5
55	16	162.2	42.9	179.7	43.7	199.1	44.9	220.0	46.5	241.7	48.7
	18	154.3	41.1	170.9	42.0	189.3	43.0	209.2	44.4	229.7	46.7
	20	146.4	39.3	162.2	40.1	179.5	41.3	198.3	42.6	217.7	44.7
	22	138.5	37.5	153.4	38.3	169.8	39.5	187.5	40.7	205.8	42.7
	24	130.7	35.8	144.6	36.5	160.0	37.5	176.7	38.7	193.9	40.6

Calculation conditions: the nominal outer diameter of the heating pipe is 20mm, the thickness of the filling layer is 50mm, the thickness of the polystyrene foam insulation layer is 20mm, and the temperature difference between the supply and return water is 10°C.

When the ground layer is made of plastic materials and thermal resistance = 0.075 (m².K/W), the heat dissipation per unit of ground and the heat loss when turning downwards can be calculated according to Table A 2.2.

Table A2.2

average water temperature (°C)	indoor air temperature (°C)	Heating tube spacing(mm)									
		300		250		200		150		100	
		Heat output	heat loss	Heat output	heat loss	Heat output	heat loss	Heat output	heat loss	Heat output	heat loss
35	16	62.0	23.2	66.8	23.5	72.0	23.5	77.2	24.2	82.3	24.8
	18	55.9	21.3	60.3	21.6	64.9	21.6	69.5	22.1	74.2	22.6
	20	49.9	19.3	53.7	19.9	58.0	19.9	62.0	20.0	66.1	20.6
	22	43.9	17.4	47.2	17.9	51.0	17.9	54.5	17.9	58.0	18.5
	24	38.0	15.3	40.8	15.9	44.1	15.9	47.1	15.9	50.1	16.3
40	16	78.5	28.9	84.7	29.6	91.5	29.6	98.1	30.1	104.8	30.9
	18	72.4	27.1	78.1	27.7	84.4	27.7	90.5	27.8	96.5	28.8
	20	66.3	25.1	71.5	25.7	77.2	25.7	82.8	25.8	88.3	26.8
	22	60.2	23.1	64.9	23.7	70.1	23.7	75.1	23.8	80.1	24.5
	24	54.1	21.1	58.3	21.7	63.0	21.7	67.5	21.7	71.9	22.3
45	16	95.4	34.6	103.0	35.4	111.4	35.4	119.5	36.1	127.7	37.2
	18	89.2	32.5	96.3	33.4	104.1	33.4	111.7	33.9	119.4	35.0
	20	83.0	30.6	89.6	31.5	96.9	31.5	104.0	31.8	111.0	32.9
	22	76.9	28.5	82.9	29.5	89.7	29.5	96.2	29.6	102.7	30.8
	24	70.7	26.9	76.3	27.5	82.5	27.5	88.5	27.5	94.4	28.4
50	16	112.5	40.2	121.6	41.2	131.5	41.2	141.3	41.9	151.1	43.4
	18	106.2	38.4	114.8	39.3	124.2	39.3	133.4	40.1	142.6	41.3
	20	100.0	36.4	108.0	37.4	116.9	37.4	125.5	38.1	134.2	39.1
	22	93.8	34.5	101.3	35.4	109.6	35.4	117.7	35.8	125.7	37.0
	24	87.6	32.3	94.6	33.4	102.3	33.4	109.8	33.6	117.4	34.8
55	16	129.8	45.7	140.3	47.1	151.1	47.1	163.4	47.7	174.8	49.6
	18	122.8	44.0	132.9	44.0	145.1	44.0	155.9	45.5	166.7	47.0
	20	117.2	42.1	126.8	42.7	137.2	42.7	147.5	43.7	157.7	45.4
	22	110.9	40.3	120.0	41.0	129.8	41.0	139.5	41.8	149.2	43.4
	24	104.7	38.2	113.2	39.2	122.5	39.2	131.6	39.9	140.7	41.2

Calculation conditions: the nominal outer diameter of the heating pipe is 20mm, the thickness of the filling layer is 50mm, the thickness of the polystyrene foam insulation layer is 20mm, and the temperature difference between the supply and return water is 10°C.

When the ground floor is made of wooden floor material and the thermal resistance is 0.1 (m².K/W), the heat dissipation per unit of ground and the heat loss due to downward transfer can be calculated according to Table A 2.3.

Table A2.3

average water temperature (°C)	indoor air temperature (°C)	Heating tube spacing (mm)									
		300		250		200		150		100	
		Heat output	heat loss	Heat output	heat loss	Heat output	heat loss	Heat output	heat loss	Heat output	heat loss
35	16	57.4	23.1	61.5	23.1	65.6	23.9	69.7	24.6	73.7	25.4
	18	51.8	21.4	55.5	21.4	59.2	21.7	62.9	22.4	66.5	23.1
	20	46.2	19.2	49.5	19.2	52.7	19.9	56.1	20.2	59.3	20.9
	22	40.7	17.7	43.5	17.7	46.5	17.5	49.3	18.0	52.1	18.7
	24	35.2	15.2	37.7	15.2	40.2	15.6	42.7	15.8	45.1	16.4
40	16	72.6	29.3	77.8	29.3	83.1	29.8	88.5	30.6	93.7	31.6
	18	66.9	27.3	71.8	27.3	76.6	27.7	81.5	28.4	86.3	29.4
	20	61.4	24.7	65.8	24.7	70.2	25.6	74.6	26.4	79.0	27.2
	22	55.8	22.7	59.8	22.7	63.7	23.6	67.8	24.2	71.7	24.9
	24	50.2	20.7	53.8	20.7	57.3	21.3	60.9	21.9	64.5	22.7
45	16	88.2	34.4	94.7	34.4	101.1	35.4	107.6	36.5	114.0	37.8
	18	82.4	32.4	88.5	32.4	94.5	33.6	100.6	34.6	106.6	35.6
	20	76.7	30.4	82.4	30.4	87.9	31.5	93.6	32.4	99.2	33.5
	22	71.1	28.4	76.3	28.4	81.4	29.4	86.7	30.1	91.8	31.2
	24	65.6	26.4	70.2	26.4	74.9	27.4	79.7	28.1	84.4	29.0
50	16	103.9	40.1	111.6	40.1	119.2	41.5	127.0	42.6	134.6	44.3
	18	98.2	38.1	105.4	38.1	112.6	39.3	119.9	40.5	127.1	42.0
	20	92.4	36.1	99.2	36.1	106.0	37.4	112.9	38.5	119.6	39.9
	22	86.7	34.2	93.0	34.2	99.4	35.3	105.8	36.3	112.2	37.6
	24	81	32.2	86.9	32.2	92.8	33.2	98.8	34.2	104.7	35.4
55	16	119.7	45.9	128.6	45.9	137.5	47.3	146.6	48.8	155.5	50.5
	18	114	43.8	122.4	43.8	130.8	45.5	139.5	46.8	148.0	48.5
	20	108.1	41.9	116.2	41.9	124.2	43.5	132.4	44.5	140.5	46.2
	22	102.3	39.9	110.0	39.9	117.5	41.5	125.3	42.4	132.9	44.1
	24	96.6	37.9	103.8	37.9	111.0	39.1	118.2	40.3	125.4	41.7

Calculation conditions: the nominal outer diameter of the heating pipe is 20mm, the thickness of the filling layer is 50mm, the thickness of the polystyrene foam insulation layer is 20mm, and the temperature difference between the supply and return water is 10°C.

Schedule B: Coefficient of Expansion of Water

temperature	Coefficient of expansion
0	0.00013
10	0.00025
15	0.00085
20	0.00180
25	0.00289
30	0.00425
35	0.00582
40	0.00782
45	0.00984
50	0.01207
55	0.01447
60	0.01704
65	0.01979
70	0.02269
75	0.02575
80	0.02898
85	0.03236
90	0.03590
95	0.03958
100	0.04342

Note: The expansion coefficient of water at different temperatures relative to its volume at 4°C.